

Agilent 1100 Series Binary Pump

Reference Manual



Agilent Technologies
Innovating the HP Way

© Copyright Agilent
Technologies 1999

All rights reserved.
Reproduction, adaption,
or translation without
prior written permission
is prohibited, except as
allowed under the
copyright laws.

Part No. G1312-90003

Edition 01/00

Printed in Germany

Warranty

The information
contained in this
document is subject to
change without notice.

*Agilent Technologies
makes no warranty of
any kind with regard to
this material,
including, but not
limited to, the implied
warranties or
merchantability and
fitness for a particular
purpose.*

Agilent Technologies
shall not be liable for
errors contained herein
or for incidental or
consequential damages
in connection with the
furnishing, performance,
or use of this material.

WARNING

For details of safety,
see Safety Information
on page 270.

Warning Symbols Used In This Book



The apparatus is marked
with this symbol when
the user should refer to
the instruction manual
in order to protect the
apparatus against
damage.

Reference Manual

In This Book

This manual contains technical reference information about the Agilent 1100 Series binary pump. The manual describes the following:

- installation,
- optimizing performance,
- troubleshooting,
- repairing,
- parts and materials,
- introduction and theory of operation,
- screens of local control module and
- specifications.

Contents

1 Installing the Pump

How to install the binary pump 13

Site Requirements 14

Unpacking the Binary Pump 17

Optimizing the Stack Configuration 19

Installing the Binary Pump 21

Flow Connections of the Binary Pump with Solvent Selection Valve 24

Flow Connections of the Binary Pump without Solvent Selection Valve 27

Priming and Purging the System 30

2 Optimizing Performance

How to optimize the binary pump to achieve best chromatographic results 33

Hints for Successful Use of the Binary Pump 34

Solvent Information 36

Prevent Blocking of Solvent Filters 37

When to Use a Vacuum Degasser 39

When to Use the Continuous Seal Wash Option 40

When to Use Alternative Seals 41

When to Remove the Static Mixer 42

How to Optimize the Compressibility Compensation Setting 43

3 Troubleshooting and Test Functions

The binary pump's built-in troubleshooting and test

functions 45

Status Indicators 48

Power Supply Indicator 49
Instrument Status Indicator 49

Error Messages 50

Timeout 51
Shutdown 52
Remote Timeout 53
Synchronization Lost 54
Leak 55
Leak Sensor Open 56
Leak Sensor Short 57
Compensation Sensor Open 58
Compensation Sensor Short 59
Fan Failed 60
Open Cover 61
Restart Without Cover 62
Zero Solvent Counter 63
Pressure Above Upper Limit 64
Pressure Below Lower Limit 65
Pressure Signal Missing 66
Valve Failed 67
Missing Pressure Reading 68
Pump Configuration 69
Valve Fuse 70
Inlet-Valve Fuse 71
Temperature Out of Range 72
Temperature Limit Exceeded 73
Motor-Drive Power 74

Encoder Missing	75
Inlet-Valve Missing	76
Servo Restart Failed	77
Pump Head Missing	78
Index Limit	79
Index Adjustment	80
Index Missing	81
Stroke Length	82
Initialization Failed	83
Wait Timeout	84

Pressure Test 85

Running the Pressure Test	87
Evaluating the Results	89

Leak Test 91

Description	92
Running the Leak Test	94
Evaluating the Results	96

4 Repairing the Pump

Instructions on simple, routine repair procedures as well as more extensive repairs requiring exchange of internal parts 103

Cleaning the Binary Pump	105
Using the ESD Strap	106
Overview	107

Simple Repair Procedures 108

Exchanging the Active Inlet Valve Cartridge or the Active Inlet Valve 109

Exchanging the Outlet Ball Valve Sieve or the Complete Valve 112

Exchanging the Purge Valve Frit or the Purge Valve 114

Exchanging the Solvent Selection Valve 117

Removing and Disassembling the Pump Head Assembly 119

Exchanging the Pump Seals and Seal Wear-in Procedure 121

Exchanging the Plungers 124

Installing the Continuous Seal Wash Option 125

Exchanging the Wash Seals 127

Reassembling the Pump Head Assembly 129

Exchanging the Optional Interface Board 131

Exchanging Internal Parts 132

Removing the Top Cover and Foam 133

Exchanging the High Pressure Pump Main Board (HPM Board) 136

Exchanging the Damper 143

Exchanging the Fan 145

Exchanging a Pump Drive 148

Exchanging the Power Supply 151

Exchanging the Leak Sensor 156

Exchanging Status Light Pipe 158

Assembling the Main Cover 159

Replacing the Top Cover and Foam 160

5 Parts and Materials

Detailed illustrations and lists for identification of parts and materials 163

Control Module(B-Version)	167
Solvent Cabinet	168
Bottle-Head Assembly	169
Hydraulic Path with Solvent Selection Valve	170
Hydraulic Path without Solvent Selection Valve	172
Cover Parts	174
Sheet Metal Kit	175
Foam Parts	176
Power and Status Light Pipes	177
Leak Parts	178
Pump-Head Assembly	179
Pump-Head Assembly with Seal Wash	181
Outlet Ball Valve Assembly	183
Purge-Valve Assembly	184
Active Inlet Valve Assembly	185
Accessory Kit G1311-68705	186
Seal Wash Option 01018-68722	187

Cable Overview 188

Analog Cables	190
Remote Cables	192
BCD Cables	197
Auxiliary Cable	199
CAN Cable	199
External Contact Cable	200
RS-232 Cable Kit	201
LAN Cables	202

6 Introduction to the Binary Pump

An introduction to the pump, instrument overview, theory of operation, external communication and internal connectors 203

Introduction to the Binary Pump	204
Electrical Connections	210
Instrument Layout	212
Early Maintenance Feedback (EMF)	213
The Electronics	215
Firmware Description	221
Optional Interface Boards	223
Agilent 1100 Series Interfaces	225
Setting the 8-bit Configuration Switch	230
The Main Power Supply Assembly	235

7 Control Module Screens for the Binary Pump

Screens available from the Analysis screen	239
Screens available from the System screen	248
Screens available from the Records screen	250
Diagnostics and Tests	256

8 Specifications

Performance specifications of the binary pump 259

Performance Specifications	260
----------------------------	-----

Warranty Statement 267
Safety Information 270
Lithium Batteries Information 273
Radio Interference 274
Sound Emission 274
Solvent Information 275
Agilent Technologies on Internet 276

Installing the Pump

How to install the binary pump

Installing the Pump

Site Requirements

A suitable environment is important to ensure optimum performance of the binary pump.

Power Consideration

The binary pump power supply has wide ranging capability (see Table 1 on page 16). It accepts any line voltage in the range described in the above mentioned table. Consequently there is no voltage selector in the rear of the binary pump. There are also no externally accessible fuses, because automatic electronic fuses are implemented in the power supply.

WARNING

To disconnect the binary pump from line, unplug the power cord. The power supply still uses some power, even if the power switch on the front panel is turned off.

WARNING

Shock hazard or damage of your instrumentation can result, if the devices are connected to a line voltage higher than specified.

Power Cords

Different power cords are offered as options with the binary pump. The female end of each of the power cords is identical. It plugs into the power-input socket at the rear of the binary pump. The male end of each of the power cords is different and designed to match the wall socket of a particular country or region.

WARNING

Never operate your instrumentation from a power outlet that has no ground connection. Never use a power cord other than the power cord designed for your region.

WARNING

Never use cables other than the ones supplied by Agilent Technologies to ensure proper functionality and compliance with safety or EMC regulations.

Bench Space

The binary pump dimensions and weight (see Table 1) allow to place the binary pump on almost any laboratory bench. It needs an additional 2.5 cm (1.0 inches) of space on either side and approximately 8 cm (3.1 inches) in the rear for the circulation of air and electric connections.

If the bench should carry a complete Agilent 1100 Series system, make sure that the bench is designed to carry the weight of all the modules.

NOTE

The pump should be operated in a horizontal position!

Environment

Your binary pump will work within specifications at ambient temperatures and relative humidity as described in Table 1.

CAUTION

Do not store, ship or use your binary pump under conditions where temperature fluctuations could cause condensation within the binary pump. Condensation will damage the system electronics. If your binary pump was shipped in cold weather, leave it in its box and allow it to warm slowly to room temperature to avoid condensation.

Installing the Pump
Site Requirements

Table 1 **Physical Specifications**

Type	Specification	Comments
Weight	15.5 kg (34 lbs)	
Dimensions (height × weight × depth)	180 × 345 × 435 mm (7 × 13.5 × 17 inches)	
Line voltage	100 – 120 or 220 – 240 VAC, ± 10 %	Wide-ranging capability
Line frequency	50 or 60 Hz, ± 5 %	
Power consumption	220 VA	Maximum
Ambient operating temperature	4 – 55 °C (41 – 131 °F)	
Ambient non-operating temperature	-40 – 70 °C (-4 – 158 °F)	
Humidity	< 95 %, at 25 – 40 °C (77 – 104 °F)	Non-condensing
Operating Altitude	Up to 2000 m (6500 ft)	
Non-operating altitude	Up to 4600 m (14950 ft)	For storing the binary pump
Safety standards: IEC, CSA, UL	Installation Category II, Pollution Degree 2	

Unpacking the Binary Pump

Damaged Packaging

Upon receipt of your binary pump, inspect the shipping containers for any signs of damage. If the containers or cushioning material are damaged, save them until the contents have been checked for completeness and the binary pump has been mechanically and electrically checked. If the shipping container or cushioning material is damaged, notify the carrier and save the shipping material for the carrier's inspection.

CAUTION

If there are signs of damage to the binary pump, please do not attempt to install the binary pump.

Delivery Checklist

Ensure all parts and materials have been delivered with the binary pump. The delivery checklist is shown in Table 2. To aid in parts identification, please see Chapter 5 "Parts and Materials". Please report missing or damaged parts to your local Agilent Technologies sales and service office.

Table 2

Binary Pump Checklist

Description	Quantity
Binary pump	1
Solvent cabinet	1 (5062-8591)
Solvent bottle	2 or 4* (9301-1450 amber bottle, 9301-1420 transparent bottle)
Bottle head assembly	2 or 4** (G1311-60003)
Waste tube, purge valve	1 (5042-2461, reorder number, 5m)
Power cable	1

Installing the Pump
Unpacking the Binary Pump

Table 2

Binary Pump Checklist, continued	
Description	Quantity
CAN cable, 1 m	1
Remote cable	As ordered
Signal cable	As ordered
<i>Reference Manual</i>	1
Accessory kit (see Table 3)	1

* 4 bottles when binary pump is equipped with a solvent selection valve

** 4 bottle-head assemblies when binary pump is equipped with a solvent selection valve

Accessory Kit Contents - Binary Pump

Table 3

Accessory Kit Contents G1311-68705		
Description	Part Number	Quantity
Capillary, pump to injection device	G1312-67305	1
Seal insert tool	01018-23702	1
Wrench; 1/4 – 5/16 inch	8710-0510	1
Wrench; 14 mm	8710-1924	1
ESD wrist strap*	9300-1408	1
Hex key 4mm	8710-2392	1
Waste tube (reorder number, 5m)	5062-2463	1.2 m
Velocity regulator (reorder number)	5062-2486	2
PTFE Frit	01018-22707	5

* ESD: Electrostatic Discharge

Optimizing the Stack Configuration

If your binary pump is part of a complete 1100 series system, you can ensure optimum performance by limiting the configuration of the system stack to the following configuration. This configuration optimizes the system flow path, ensuring minimum delay volume.

Figure 1 Recommended Stack Configuration (Front View)

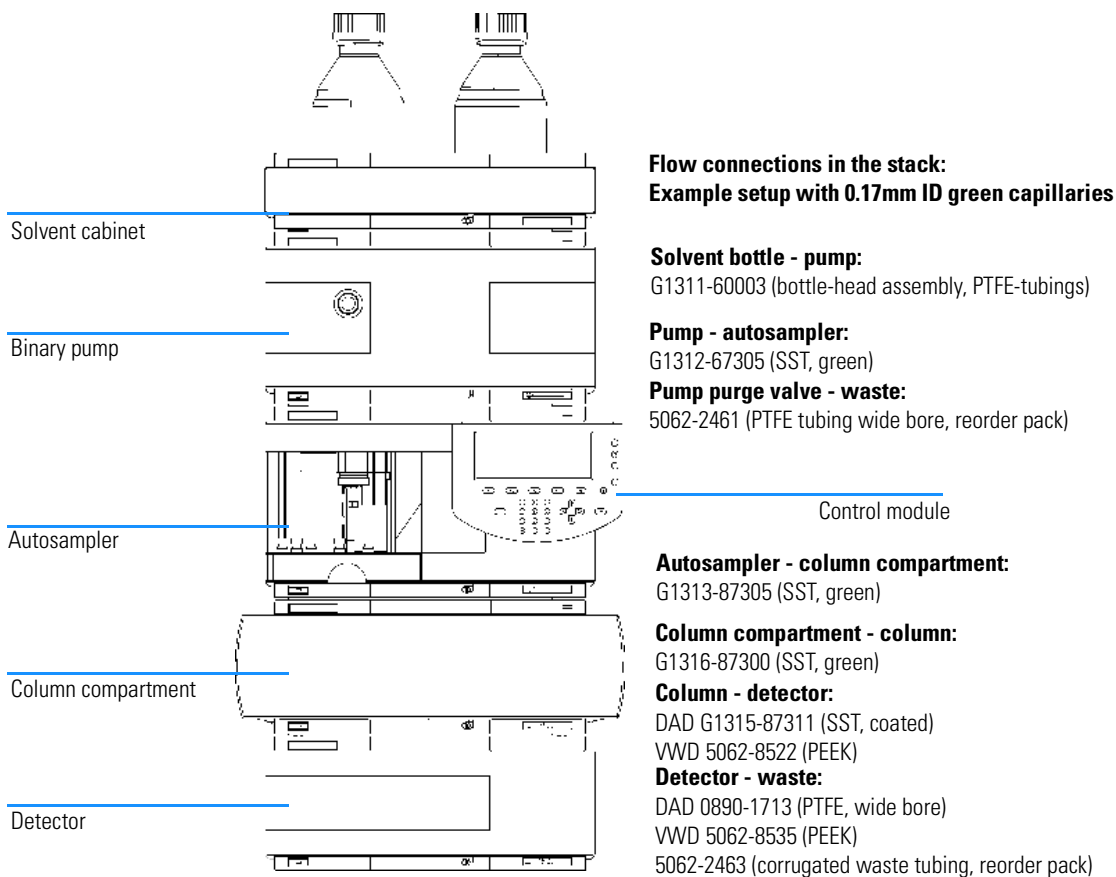

NOTE

For a detailed view of the flow connections refer to the section “Flow connections in chapter 1 of the reference manuals of the individual modules.

Figure 2

Recommended Stack Configuration (Rear View)

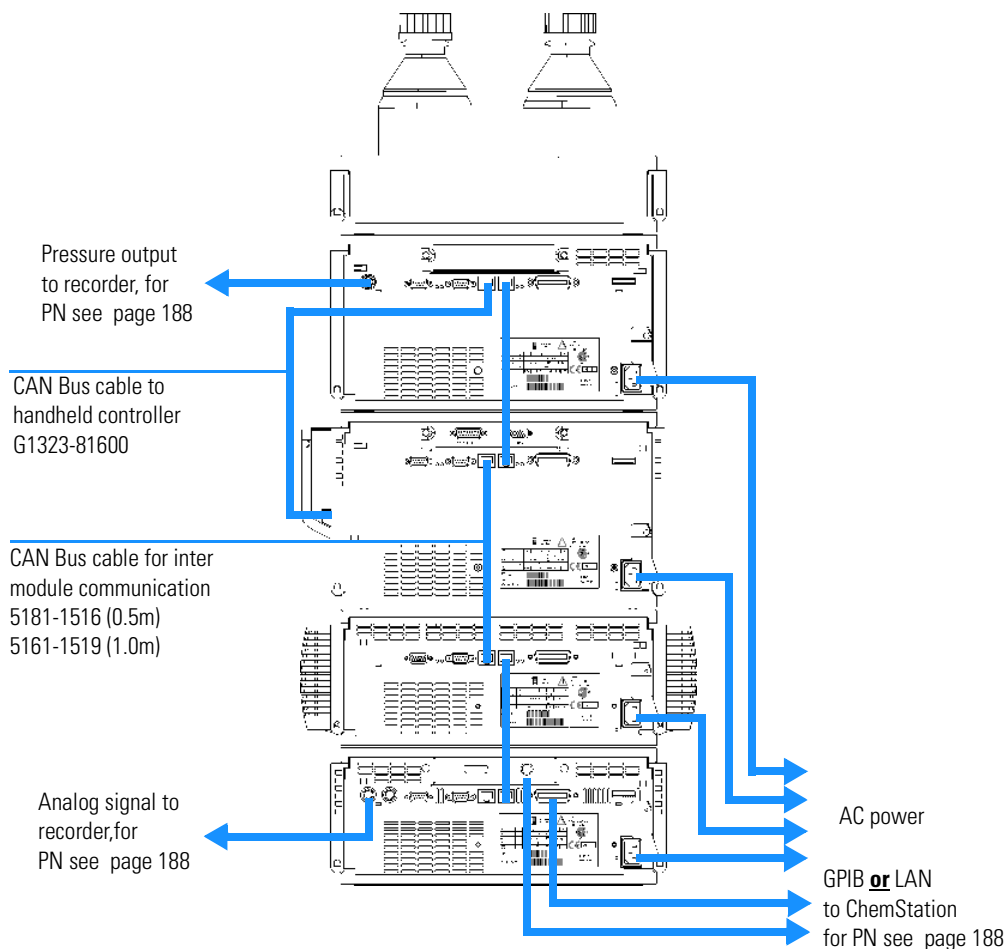

NOTE

If a single stack configuration becomes too high, e.g. if an additional module like a G1327A ALS Thermostat is added or if your bench is too high, a two stack configuration may be a better setup. Separate the stack between pump and autosampler and place the stack containing the pump on the right side of the stack containing the autosampler.

Installing the Binary Pump

Preparations	Locate bench space Provide power connections Unpack the pump
Parts required	Pump Power cord, for other cables see text below and “Cable Overview” on page 188 ChemStation and/or Control module G1323A/B

- 1 Place the binary pump on the bench in a horizontal position.
- 2 Ensure the power switch on the front of the binary pump is OFF (switch stands out).
- 3 At the rear of the binary pump move the security lever to its maximum right position.

Figure 3 **Front of Binary Pump**

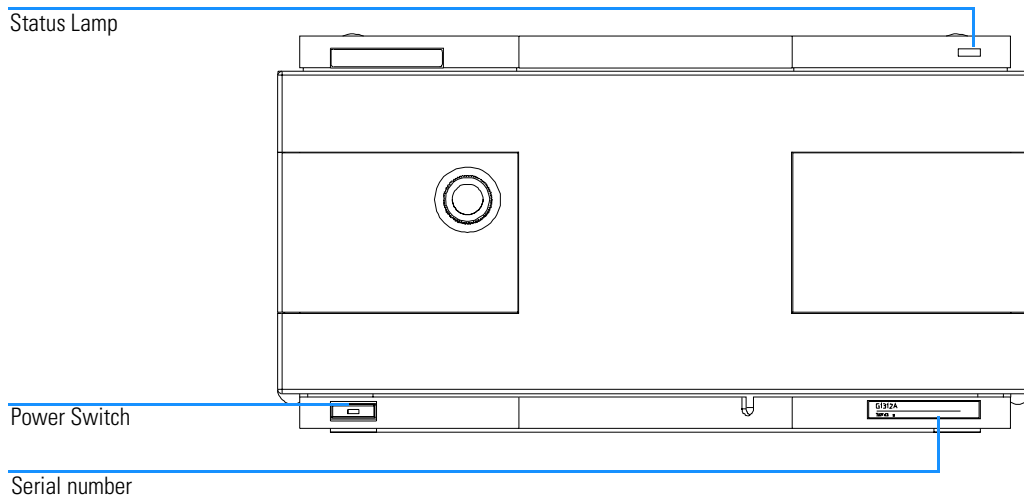

Installing the Pump
Installing the Binary Pump

- 4 Connect the power cable to the power connector at the rear of the binary pump. The security lever will prevent that the cover is opened while the power cord is connected to the binary pump.
- 5 Connect the required interface cables to the rear of the binary pump.

Figure 4 Rear of Binary Pump

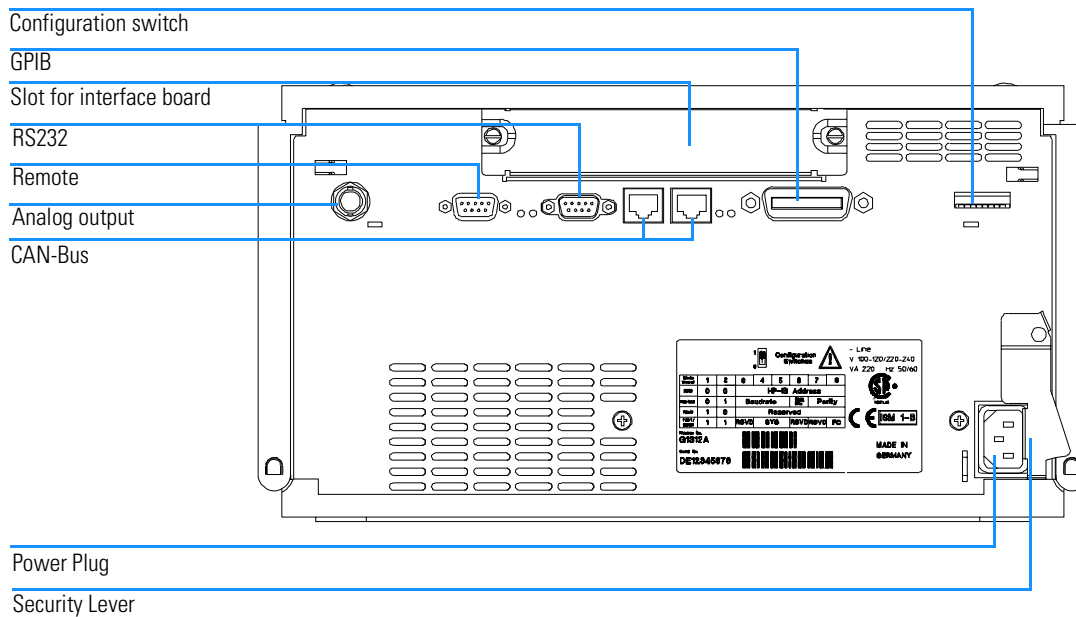

NOTE

In an Agilent 1100 Series system, the individual modules are connected through CAN cables. The Agilent 1100 Series vacuum degasser is an exception . A vacuum degasser can be connected via the APG remote connector to the other modules of the stack. The AUX output allows the user to monitor the vacuum level in the degasser chamber. An Agilent 1100 Series control module can be connected to the CAN bus at any of the modules in the system except for the degasser. The Agilent ChemStation can be connected to the system through one GPIB or LAN (requires the installation of a LAN- board) cable at any of the modules (except for the degasser), preferably at the detector (MUST for the DAD). For more information about connecting the control module or Agilent ChemStation refer to the respective user manual. For connecting the Agilent 1100 Series equipment to non-Agilent 1100 Series equipment, see Chapter 6 “Introduction to the Binary Pump”.

Installing the Binary Pump

- 6 Connect the capillary, solvent tubes and waste tubings (see “Flow Connections of the Binary Pump with Solvent Selection Valve” on page 24 or “Flow Connections of the Binary Pump without Solvent Selection Valve” on page 27).
- 7 Press in the power switch to turn on the pump.

NOTE

The power switch stays pressed in and a green indicator lamp in the power switch is on when the binary pump is turned on. When the line power switch stands out and the green light is off, the binary pump is turned off.

- 8 Purge the binary pump (see “Priming and Purging the System” on page 30).

WARNING

To disconnect the binary pump from line, unplug the power cord. The power supply still uses some power, even if the power switch on the front panel is turned off.

The pump was shipped with default configuration settings. To change these settings, see “Setting the 8-bit Configuration Switch” on page 230.

Flow Connections of the Binary Pump with Solvent Selection Valve

WARNING

When opening capillary or tube fittings solvents may leak out. Please observe appropriate safety procedures (for example, goggles, safety gloves and protective clothing) as described in the material handling and safety data sheet supplied by the solvent vendor, especially when toxic or hazardous solvents are used.

Preparation

Pump is installed in the LC system

Parts required

Other modules

Parts from accessory kit (see "Accessory Kit Contents G1311-68705" on page 18)

Two wrenches 1/4 - 5/16 inch for capillary connections

- 1 Remove the front cover by pressing the snap fasteners on both sides.

Figure 5

Removing the Front Cover

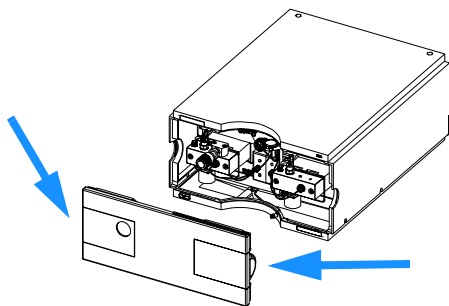

- 2 Place the solvent cabinet on top of the binary pump.
- 3 Place the bottles into the solvent cabinet and place a bottle head assembly into each bottle.
- 4 Connect the solvent tubes from the bottle head assemblies to the inlet connectors A1, A2, B1 and B2 of the solvent selection valve and label the tubes accordingly. Fix the tubes in the clips of solvent cabinet and binary pump.

Flow Connections of the Binary Pump with Solvent Selection Valve

- 5** Using a piece of sanding paper connect the waste tubing to the purge valve and place it into your waste system.
- 6** If the binary pump is not part of a Agilent1100 System stack or placed on the bottom of a stack, connect the corrugated waste tube to the waste outlet of the pump leak handling system.
- 7** Connect the outlet capillary (binary pump to injection device) to the outlet of the purge valve.
- 8** Purge your system before first use (see “Priming and Purging the System” on page 30).

Figure 6 Binary Pump with Solvent Selection Valve

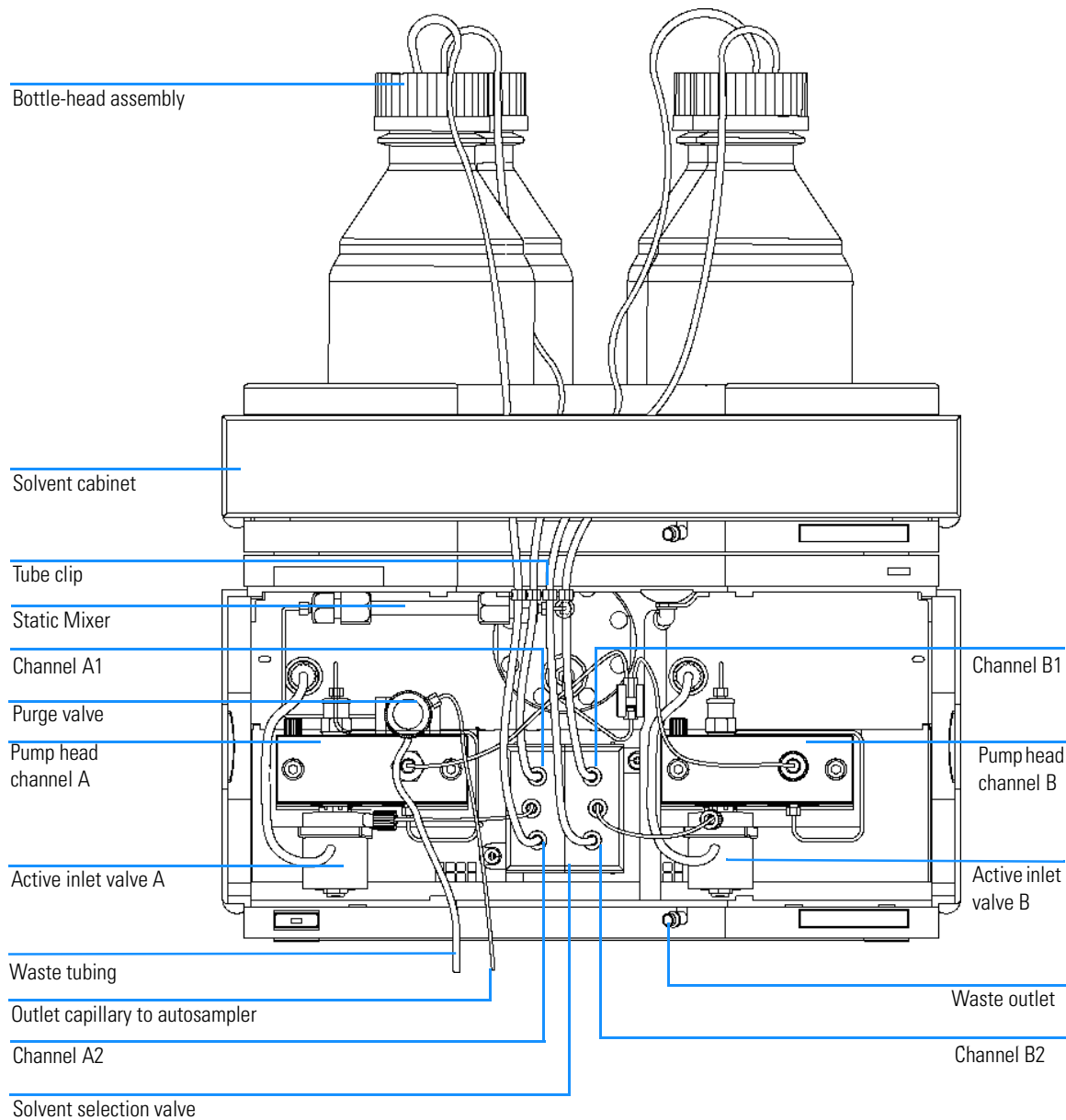

Flow Connections of the Binary Pump without Solvent Selection Valve

WARNING

When opening capillary or tube fittings solvents may leak out. Please observe appropriate safety procedures (for example, goggles, safety gloves and protective clothing) as described in the material handling and safety data sheet supplied by the solvent vendor, especially when toxic or hazardous solvents are used.

Preparation

Pump is installed in the LC system

Parts required

Other modules

Parts from accessory kit (see "Accessory Kit Contents G1311-68705" on page 18)

Two wrenches 1/4 - 5/16 inch for capillary connections

- 1 Remove the front cover by pressing the snap fasteners on both sides.

Figure 7

Removing the Front Cover

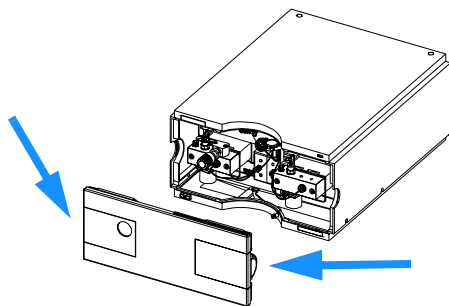

- 2 Place the solvent cabinet on top of the binary pump.
- 3 Place the bottles into the solvent cabinet and place a bottle head assembly into each bottle.

Flow Connections of the Binary Pump without Solvent Selection Valve

- 4** Connect the solvent tubes from the bottle head assemblies to the inlet adapters of the active inlet valves. Fix the tubes in the clips of solvent cabinet and binary pump.
- 5** Using a piece of sanding paper connect the waste tubing to the purge valve and place it into your waste system.
- 6** If the binary pump is not part of a Agilent1100 System stack or placed on the bottom of a stack, connect the corrugated waste tube to the waste outlet of the pump leak handling system.
- 7** Connect the outlet capillary (quaternary pump to injection device) to the outlet of the purge valve.
- 8** Purge your system before first use (see “Priming and Purging the System” on page 30).

Figure 8

Flow Connection of Binary Pump Without Solvent Selection Valve

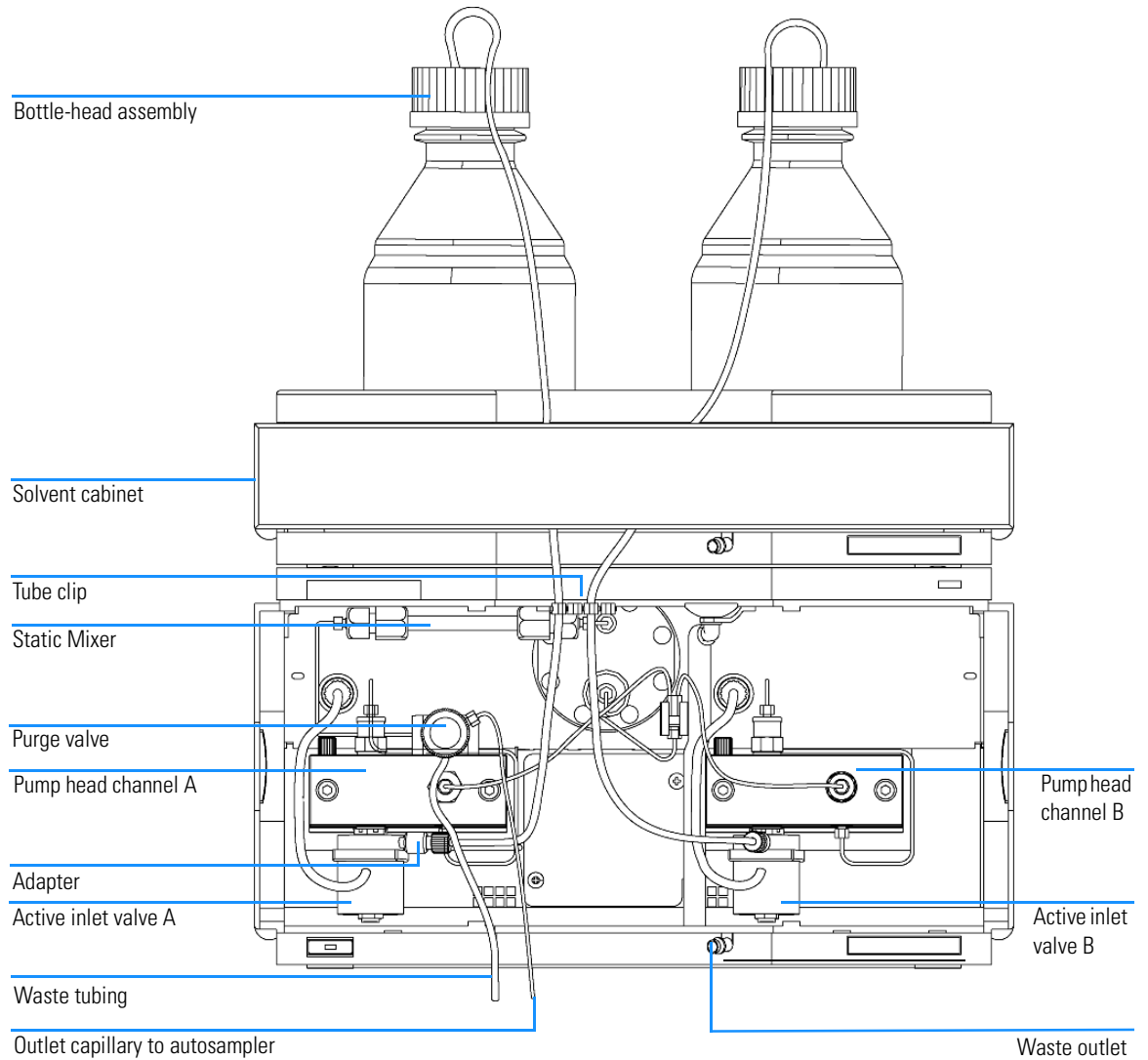

Priming and Purging the System

If a degasser is installed, it can be primed either by drawing solvent through the degasser with a syringe or by pumping with the pump.

Priming the vacuum degasser or system with a syringe is recommended, when:

- vacuum degasser or system is used for the first time, or vacuum tubes are empty, or
- changing to solvents that are immiscible with the solvent currently in the tubes.

Priming the system by using the pump at high flow rate (3–5 ml/min) is recommended, when:

- pumping system was turned off for a length of time (for example, overnight) and if volatile solvent mixtures are used, or
- solvents have been changed.

WARNING

When opening capillary or tube fittings solvents may leak out. Please observe appropriate safety procedures (for example, goggles, safety gloves and protective clothing) as described in the material handling and safety data sheet supplied by the solvent vendor, especially when toxic or hazardous solvents are used.

Priming with a Syringe

Before using a new degasser or new tubings for the first time:

- 1 Prime all tubings with at least 30 ml of iso-propanol no matter whether the channel will be used with organic mobile phase or with water.

If you are changing to a solvent that is immiscible with the solvent currently in the tubing continue as follows:

- 2 Replace the current solvent with adequate organic solvent (see Table 4 on page 32), if current solvent is organic or with water, if current solvent is an inorganic buffer or contains salt.
- 3 Disconnect solvent tube from your pump.
- 4 Connect syringe adapter to solvent tube.

Priming and Purging the System

- 5 Push syringe adapter onto syringe.
- 6 Pull syringe plunger to draw at least 30 ml of solvent through degasser and tubing.
- 7 Replace the priming solvent with the new solvent of your choice.
- 8 Pull syringe plunger to draw at least 30 ml of solvent through degasser and tubing.
- 9 Disconnect syringe adapter from solvent tube.
- 10 Connect solvent tube to your pump.
- 11 Repeat step 3 through step 10 for the other channel(s) of the binary pump.

NOTE

When priming the vacuum degasser with a syringe the solvent is drawn through the degasser tubes very quickly. The solvent at the degasser outlet will therefore not be fully degassed. Pump for approximately 10 minutes with your selected flow rate before starting any application. This will allow the vacuum degasser to properly degas the solvent in the degasser tubes.

NOTE

The pump should never be used for priming empty tubings (never let the pump run dry). Use the syringe to draw enough solvent for completely filling the tubings to the pump inlet before continueing to prime with the pump.

Priming with the Pump

When the pumping system has been turned off for a certain time (for example, overnight) oxygen will rediffuse into the solvent channel between the vacuum degasser and the pump. Solvents containing volatile ingredients will slightly lose these, if left in the degasser without flow for a prolonged period of time. Therefore priming of the vacuum degasser and the pumping system is required before starting an application.

- 1 Open the purge valve of your pump (by turning it counterclockwise) and set flow rate to 3-5 ml/min.
- 2 Flush the vacuum degasser and all tubes with at least 30 ml of solvent.
- 3 Set flow to required value of your application and close the purge valve.
- 4 Pump for approximately 10 minutes before starting your application.
- 5 Repeat step 1 through step 4 for the other channel(s) of the binary pump.

- 6 Close the purge valve and set the required composition and flow rate for your application.

Table 4

Choice of Priming Solvents for Different Purposes

Activity	Solvent	Comments
After an installation	Isopropanol	Best solvent to flush air out of the system
When switching between reverse phase and normal phase (both times)	Isopropanol	Best solvent to flush air out of the system
After an installation	Ethanol or Methanol	Alternative to Isopropanol (second choice) if no Isopropanol is available
To clean the system when using buffers	Bidistilled water	Best solvent to re-dissolve buffer crystals
After a solvent change	Bidistilled water	Best solvent to re-dissolve buffer crystals
After the installation of normal phase seals (P/N 0905-1420)	Hexane + 5% Isopropanol	Good wetting properties

Optimizing Performance

How to optimize the binary pump to achieve best chromatographic results

Hints for Successful Use of the Binary Pump

- Place solvent cabinet with the solvent bottles always on top (or at a higher level) of the binary pump.
- When using the binary pump without vacuum degasser, shortly degass your solvents (for example, water vacuum pump for 15 – 30 s in an appropriate vessel) before using them in the binary pump. If possible apply solvent conditions that will decrease the gas solubility over time (for example, warming up the solvents).
- For highest precision and reproducibility use a vacuum degasser.
- When using the binary pump with vacuum degasser — before operating the binary pump flush the degasser with at least two volumes (30 ml), especially when the pumping system was turned off for a certain length of time (for example, overnight) and volatile solvent mixtures are used in the channels (see “Priming and Purging the System” on page 30).
- Prevent blocking of solvent inlet filters (never use the pump without solvent inlet filter). Growth of algae should be avoided (see “Prevent Blocking of Solvent Filters” on page 37).
- Check purge valve frit and column frit in regular time intervals. A blocked purge valve frit can be identified by black or yellow layers on its surface or by a pressure greater than 10 bar, when pumping distilled water at a rate of 5 ml/min with an open purge valve.
- When using the binary pump at low flow rates (below 0.2 ml/min) check all 1/16-inch fittings for any signs of leaks.
- Whenever possible use a minimum flow rate of 5 µl/min per solvent channel to avoid crossflow of solvent into the unused pump channel.
- Whenever exchanging the pump seals the purge valve frit and the outlet ball valve sieve should be exchanged, too.
- When using buffer solutions, flush the system with water before switching it off. The seal wash option should be used when buffer solutions of 0.1 Molar or higher will be used for long time periods.
- Check the pump plungers for scratches when changing the piston seals. Scratched plungers will lead to micro leaks and will decrease the lifetime

Hints for Successful Use of the Binary Pump

of the seal.

- After changing the plunger seals apply the seal wear-in procedure (see “Exchanging the Pump Seals and Seal Wear-in Procedure” on page 121).
- Place the aqueous solvent on channel A and the organic solvent on channel B. The default compressibility settings are set accordingly.

Solvent Information

Always filter solvents through 0.4 µm filters, small particles can permanently block the capillaries and valves. Avoid the use of the following steel-corrosive solvents:

- Solutions of alkali halides and their respective acids (for example, lithium iodide, potassium chloride, and so on).
- High concentrations of inorganic acids like sulfuric and nitric acid, especially at higher temperatures (replace, if your chromatography method allows, by phosphoric acid or phosphate buffer which are less corrosive against stainless steel).
- Halogenated solvents or mixtures which form radicals and/or acids, for example:

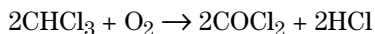

This reaction, in which stainless steel probably acts as a catalyst, occurs quickly with dried chloroform if the drying process removes the stabilizing alcohol.

- Chromatographic grade ethers, which can contain peroxides (for example, THF, dioxane, di-isopropylether) such ethers should be filtered through dry aluminium oxide which adsorbs the peroxides.
- Solvents containing strong complexing agents (e.g. EDTA).
- Mixtures of carbon tetrachloride with 2-propanol or THF dissolve stainless steel.

Prevent Blocking of Solvent Filters

Contaminated solvents or algae growth in the solvent bottle will reduce the lifetime of the solvent filter and will influence the performance of the binary pump. This is especially true for aqueous solvents or phosphate buffers (pH 4 to 7). The following suggestions will prolong lifetime of the solvent filter and will maintain the performance of the binary pump.

- Use a sterile, if possible amber, solvent bottles to slow down algae growth.
- Filter solvents through filters or membranes that remove algae.
- Exchange solvents every two days or refilter.
- If the application permits add 0.0001 to 0.001 Molar sodium azide to the solvent.
- Place a layer of argon on top of your solvent.
- Avoid exposure of the solvent bottles to direct sunlight.

Checking the Solvent Filters

The solvent filters are located on the low-pressure side of the binary pump. A blocked filter therefore does not affect the pressure readings of the binary pump. The pressure readings cannot be used to check whether the filter is blocked or not. If the solvent cabinet is placed on top of the binary pump, the filter condition can be checked in the following way:

Remove the solvent inlet tube from the inlet port of the solvent selection valve or the adapter at the active inlet valve. If the filter is in good condition the solvent will freely drip out of the solvent tube (due to hydrostatic pressure). If the solvent filter is partly blocked only very little solvent will drip out of the solvent tube.

WARNING

When opening capillary or tube fittings solvents may leak out. Please observe appropriate safety procedures (for example, goggles, safety gloves and protective clothing) as described in the material handling and safety data sheet supplied by the solvent vendor, especially when toxic or hazardous solvents are used.

Cleaning the Solvent Filters

- Remove the blocked solvent filter from the bottle-head assembly and place it in a beaker with concentrated nitric acid (35%) for one hour.
- Thoroughly flush the filter with bidistilled water (remove all nitric acid, some capillary columns can be damaged by nitric acid).
- Replace the filter.

NOTE

Never use the system without solvent filter installed.

When to Use a Vacuum Degasser

The binary pump does not necessarily require degassing. But for the following conditions the vacuum degasser is recommended:

- if your detector is used with maximum sensitivity in the low UV wavelength range,
- if your application requires highest injection precision, or
- if your application requires highest retention-time reproducibility (mandatory at flow rates below 0.5 ml/min).

Operational Hints for the Vacuum Degasser

If you are using the vacuum degasser for the first time, if the vacuum degasser was switched off for any length of time (for example, overnight), or if the vacuum degasser lines are empty, you should prime the vacuum degasser before running an analysis.

The vacuum degasser can be primed either by drawing solvent through the degasser with a syringe or by pumping with the binary pump.

Priming the degasser with a syringe is recommended, when:

- vacuum degasser is used for the first time, or vacuum tubes are empty, or
- changing to solvents that are immiscible with the solvent currently in the vacuum tubes.

Priming the vacuum degasser by using the pump at high flow rate (3 - 5 ml/min) is recommended, when:

- binary pump was turned off for a length of time (for example, during night) and volatile solvent mixtures are used, or
- solvents have been changed.

For more information see the *Reference Manual* for the Agilent 1100 Series vacuum degasser.

When to Use the Continuous Seal Wash Option

Highly-concentrated buffer solutions will reduce the lifetime of the seals and plungers in your binary pump. The seal wash option allows to maintain the seal lifetime by flushing the back side of the seal with a wash solvent.

The continuous seal wash option is strongly recommended when buffer concentrations of 0.1 Molar or higher will be used for long time periods in the binary pump.

The continuous seal wash option can be ordered by quoting part number 01018-68722 (kit contains all parts needed for one pump head).

The seal wash option comprises a support ring, secondary seal, gasket and seal keeper for both plunger sides. A wash bottle filled with water /isopropanol (90/10) should be placed above the binary pump in the solvent cabinet and gravity will maintain a flow through the pump head removing all possible buffer crystals from the back of the pump seal.

NOTE

Running dry is the worst case for a seal and drastically reduces its lifetime.

The seal will build up sticky layers on the surface of the plunger. These sticky layers will also reduce the lifetime of the primary seal. Therefore the tubes of the wash option should always be filled with solvent to prolong the lifetime of the wash seal. Always use a mixture of bidistilled water (90 %) and isopropanol (10 %) as wash solvent. This mixture prevents bacteria growth in the wash bottle and reduces the surface tension of the water. The flow rate should be regulated to approximately 20 drops/minute. This can be done with the velocity regulator supplied with the accessory kit.

For information on the installation of the continuous seal wash option refer to “Installing the Continuous Seal Wash Option” on page 125.

When to Use Alternative Seals

The standard seals for the binary pump can be used for most applications. However applications that use normal phase solvents (for example, hexane) are not suited for the standard seals and require a different seals when used for a longer time in the binary pump.

For applications that use normal phase solvents (for example, hexane) we recommend the use of the polyethylene seals, part number 0905-1420 (pack of 2). These seals have less abrasion compared to the standard seals.

NOTE

Polyethylene seals have a limited pressure range 0–200 bar. When used above 200 bar their lifetime will be significantly reduced. **DO NOT** apply the seal wear-in procedure performed with new standard seals at 400 bar.

When to Remove the Static Mixer

The binary pump is equipped with a static mixer. The total delay volume of the pump is 600 – 900 μl . The mixer has a volume of 420 μl .

The static mixer and both connecting capillaries can be replaced by a small capillary (G1312-67301) under the following conditions:

- the delay volume of the pump should be reduced to a minimum for fastest gradient response, and
- the detector is used at medium or low sensitivity.

NOTE

Removing the mixer will result in an increase of the composition ripple and higher detector noise.

How to Optimize the Compressibility Compensation Setting

The compressibility compensation default settings are 50×10^{-6} /bar (best for most aqueous solutions) for pump head A and 115×10^{-6} /bar (to suit organic solvents) for pump head B. The settings represent average values for aqueous solvents (A side) and organic solvents (B side). Therefore it is always recommended to use the aqueous solvent on the A side of the pump and the organic solvent on the B side. Under normal conditions the default settings reduce the pressure pulsation to values (below 1 % of system pressure) that will be sufficient for most applications. If the compressibility values for the solvents used differ from the default settings, it is recommended to change the compressibility values accordingly. Compressibility settings can be optimized by using the values for various solvents described in Table 5 on page 44. If the solvent in use is not listed in the compressibility table, when using premixed solvents and if the default settings are not sufficient for your application the following procedure can be used to optimize the compressibility settings:

- 1 Start channel A of the binary pump with the required flow rate.
- 2 Before starting the optimization procedure, the flow must be stable. Use degassed solvent only. Check the tightness of the system with the pressure test (see “Pressure Test” on page 85).
- 3 Your pump must be connected to a Chemstation or handheld controller, the pressure and %-ripple can be monitored with one of these instruments, otherwise connect a signal cable between the pressure output of the isocratic pump and a recording device (for example, 339X integrator) and set parameters.
 - Zero 50 %
 - Att 2³
 - Chart Speed 10 cm/min
- 4 Start the recording device with the plot mode.
- 5 Starting with a compressibility setting of 10×10^{-6} /bar increase the value in steps of 10. Re-zero the integrator as required. The compressibility compensation setting that generates the smallest pressure ripple is the optimum value for your solvent composition.

Table 5

Solvent Compressibility	
Solvent (pure)	Compressibility ($10^{-6}/\text{bar}$)
Acetone	126
Acetonitrile	115
Benzene	95
Carbon tetrachloride	110
Chloroform	100
Cyclohexane	118
Ethanol	114
Ethyl acetate	104
Heptane	120
Hexane	150
Isobutanol	100
Isopropanol	100
Methanol	120
1-Propanol	100
Toluene	87
Water	46

- 6 Repeat step 1 through step 5 for the B channel of your binary pump.

Troubleshooting and Test Functions

The binary pump's built-in troubleshooting and test functions

Troubleshooting and Test Functions

This chapter describes the instrument's built in troubleshooting and test functions.

Status Indicators

The binary pump is provided with two status indicators which indicate the operational state (prerun, run, and error states) of the binary pump. The status indicators provide a quick visual check of the operation of the binary pump (see "Status Indicators" on page 48).

Error Messages

In the event of an electronic, mechanical or hydraulic failure, the binary pump generates an error message in the user interface. The following pages describe the meaning of the error messages. For each message, a short description of the failure, a list of probable causes of the problem, and a list of suggested actions to fix the problem are provided (see "Error Messages" on page 50).

Pressure Test

The pressure test is a quick test designed to determine the pressure tightness of the system. After exchanging flow path components (e.g., pump seals or injection seal), use this test to verify the system is pressure tight up to 400 bar (see "Pressure Test" on page 85).

Leak Test

The leak test is a diagnostic test designed to determine the pressure tightness of the binary pump. When a problem with the binary pump is suspected, use this test to help troubleshoot the binary pump and its pumping performance (see "Leak Test" on page 91).

Status Indicators

Two status indicators are located on the front of the binary pump. The lower left one indicates the power supply status, the upper right one indicates the instrument status.

Figure 9 **Location of Status Indicators**

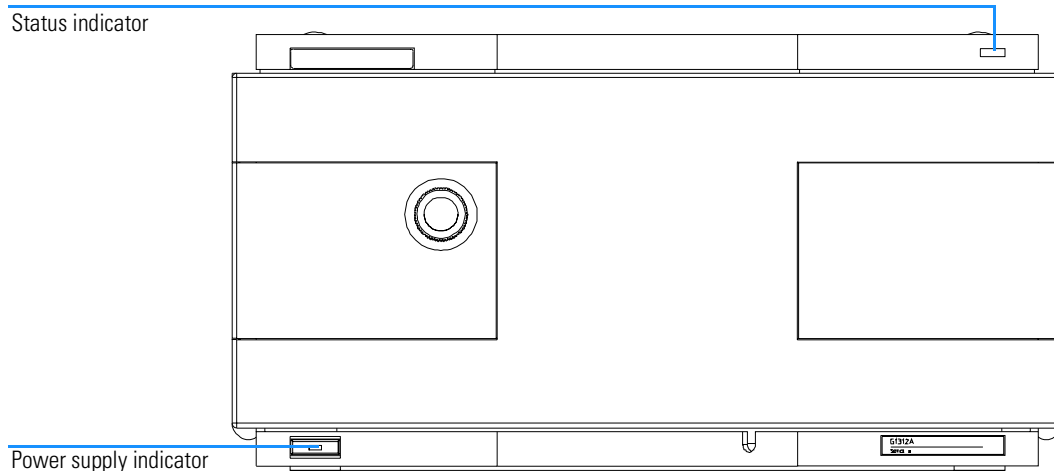

Power Supply Indicator

The power supply indicator is integrated into the main power switch. When the indicator is illuminated (*green*) the power is **ON**.

When the indicator is off, the module is turned OFF. Otherwise check power connections, availability of power or check functioning of the power supply.

Instrument Status Indicator

The instrument status indicator indicates one of four possible instrument conditions:

- When the status indicator is *OFF* (and power switch light is on), the binary pump is in a *prerun* condition, and is ready to begin an analysis.
- A *green* status indicator, indicates the binary pump is performing an analysis (*run mode*).
- A *yellow* indicator indicates a *not-ready* condition. The binary pump is in a not-ready state when it is waiting for a specific condition to be reached or completed (for example, immediately after changing a setpoint), or while a self-test procedure is running.
- An *error* condition is indicated when the status indicator is *red*. An error condition indicates the binary pump has detected an internal problem which affects correct operation of the instrument. Usually, an error condition requires attention (for example, leak, defective internal components). An error condition always interrupts the analysis.
- A *flashing yellow* status indicator indicates that the module is in its *resident mode*. Call your local service provider for assistance upon observing this error condition.
- A *flashing red* status indicator indicates a severe error during the *startup* procedure of the module. Call your local service provider for assistance upon observing this error condition.

Error Messages

Error messages are displayed in the user interface when an electronic, mechanical, or hydraulic (flow path) failure occurs which requires attention before the analysis can be continued (for example, repair, frit exchange or exchange of consumables required). In the event of such a failure, the red status indicator at the front of the module is switched on, and an entry is written into the instrument logbook.

Timeout

The timeout threshold was exceeded.

Probable Causes

- The analysis was completed successfully, and the timeout function switched off the binary pump as requested.
- A not-ready condition was present during a sequence or multiple-injection run for a period longer than the timeout threshold.

Suggested Actions

- Check the logbook for the occurrence and source of a not-ready condition. Restart the analysis where required.

Shutdown

An external instrument has generated a shut-down signal on the remote line.

The binary pump continually monitors the remote input connectors for status signals. A LOW signal input on pin 4 of the remote connector generates the error message.

Probable Causes

- Leak detected in another module with a CAN connection to the system.
- Leak detected in an external instrument with a remote connection to the system.
- Shut-down in an external instrument with a remote connection to the system.
- The degasser failed to generate sufficient vacuum for solvent degassing.

Suggested Actions

- Fix the leak in the external instrument before restarting the binary pump.
- Check external instruments for a shut-down condition.
- Check the vacuum degasser for an error condition. Refer to the *Reference Manual* for the Agilent 1100 Series vacuum degasser.

Remote Timeout

A not-ready condition is still present on the remote input.

When an analysis is started, the system expects all not-ready conditions (e.g. a not-ready condition during detector balance) to switch to run conditions within one minute of starting the analysis. If a not-ready condition is still present on the remote line after one minute the error message is generated.

Probable Causes

- Not-ready condition in one of the instruments connected to the remote line.
- Defective remote cable.
- Defective components in the instrument showing the not-ready condition.

Suggested Actions

- Ensure the instrument showing the not-ready condition is installed correctly, and is set up correctly for analysis.
- Exchange the remote cable.
- Check the instrument for defects (refer to the instrument's reference documentation).

Synchronization Lost

During an analysis, the internal synchronization or communication between one or more of the modules in the system has failed.

The system processors continually monitor the system configuration. If one or more of the modules is no longer recognized as being connected to the system, the error message is generated.

Probable Causes

- CAN cable disconnected.
- Defective CAN cable.
- Defective main board in another module.

Suggested Actions

- Ensure all the CAN cables are connected correctly.
- Switch off the system. Restart the system, and determine which module or modules are not recognized by the system.
- Ensure all CAN cables are installed correctly.

Leak

Leak

A leak was detected in the binary pump.

The signals from the two temperature sensors (leak sensor and board-mounted temperature-compensation sensor) are used by the leak algorithm to determine whether a leak is present. When a leak occurs, the leak sensor is cooled by the solvent. This changes the resistance of the leak sensor which is sensed by the leak-sensor circuit on the HPM board.

Probable Causes

- Loose fittings.
- Broken capillary.
- Loose or leaking purge valve, active inlet valve, or outlet ball valve.
- Defective pump seals.

Suggested Actions

- Ensure all fittings are tight.
- Exchange defective capillaries.
- Ensure pump components are seated correctly. If there are still signs of a leak, exchange the appropriate seal (purge valve, active inlet valve, outlet ball valve).
- Exchange the pump seals.

Leak Sensor Open

The leak sensor in the binary pump has failed (open circuit).

The current through the leak sensor is dependent on temperature. A leak is detected when solvent cools the leak sensor, causing the leak-sensor current to change within defined limits. If the current falls outside the lower limit, the error message is generated.

Probable Causes

- Leak sensor not connected to the HPM board.
- Defective leak sensor.
- Leak sensor incorrectly routed, being pinched by a metal component.

Suggested Actions

- Ensure the leak sensor is connected correctly.
- Exchange the leak sensor.

Leak Sensor Short

The leak sensor in the binary pump has failed (short circuit).

The current through the leak sensor is dependent on temperature. A leak is detected when solvent cools the leak sensor, causing the leak-sensor current to change within defined limits. If the current increases above the upper limit, the error message is generated.

Probable Causes

- Defective leak sensor.
- Leak sensor incorrectly routed, being pinched by a metal component.

Suggested Actions

- Exchange the leak sensor.

Compensation Sensor Open

The ambient-compensation sensor (NTC) on the HPM board in the binary pump has failed (open circuit).

The resistance across the temperature compensation sensor (NTC) on the HPM board is dependent on ambient temperature. The change in resistance is used by the leak circuit to compensate for ambient temperature changes. If the resistance across the sensor increases above the upper limit, the error message is generated.

Probable Causes

- Defective HPM board.

Suggested Actions

- Exchange the HPM board.

Compensation Sensor Short

The ambient-compensation sensor (NTC) on the HPM board in the binary pump has failed (short circuit).

The resistance across the temperature compensation sensor (NTC) on the HPM board is dependent on ambient temperature. The change in resistance is used by the leak circuit to compensate for ambient temperature changes. If the resistance across the sensor falls below the lower limit, the error message is generated.

Probable Causes

- Defective HPM board.

Suggested Actions

- Exchange the HPM board.

Fan Failed

The cooling fan in the binary pump has failed.

The hall sensor on the fan shaft is used by the HPM board to monitor the fan speed. If the fan speed falls below 2 revolutions/second for longer than 5 seconds, the error message is generated.

Probable Causes

- Fan cable disconnected.
- Defective fan.
- Defective HPM board.
- Improperly positioned cables or wires obstructing fan blades.

Suggested Actions

- Ensure the fan is connected correctly.
- Exchange fan.
- Exchange the HPM board.
- Ensure the fan is not mechanically blocked.

Open Cover

The top foam has been removed.

The sensor on the HPM board detects when the top foam is in place. If the foam is removed, the fan is switched off, and the error message is generated.

Probable Causes

- The top foam was removed during operation.
- Foam not activating the sensor.
- Sensor defective.
- Rear of the module is exposed to strong direct sunlight.

Suggested Actions

- Replace the top foam.
- Exchange the HPM board.
- Ensure that the rear of the module is not exposed to strong sunlight.

Restart Without Cover

The binary pump was restarted with the top cover and foam open.

The sensor on the HPM board detects when the top foam is in place. If the binary pump is restarted with the foam removed, the binary pump switches off within 30 s, and the error message is generated.

Probable Causes

- The binary pump started with the top cover and foam removed.
- Rear of the module is exposed to strong direct sunlight.

Suggested Actions

- Replace the top cover and foam.
- Ensure that the rear of the module is not exposed to strong sunlight.

Zero Solvent Counter

Pump firmware version A.02.32 and higher allow to set solvent bottle fillings at the ChemStation (revision 5.xx and higher). If the volume level in the bottle falls below the specified value the error message appears when the feature is configured accordingly.

Probable Causes

- Volume in bottle below specified volume.
- Incorrect setting of limit.

Suggested Actions

- Refill bottles and reset solvent counters.

Pressure Above Upper Limit

The system pressure has exceeded the upper pressure limit.

Probable Causes

- Upper pressure limit set too low.
- Blockage in the flowpath (after the damper).
- Defective damper.
- Defective HPM board.

Suggested Actions

- Ensure the upper pressure limit is set to a value suitable for the analysis.
- Check for blockage in the flowpath. The following components are particularly subject to blockage:
 - purge-valve frit.
 - needle (autosampler),
 - seat capillary (autosampler),
 - sample loop (autosampler), and
 - column frits.
 - capillaries with low internal diameters (e.g. 0.12mm id).
- Exchange the damper.
- Exchange the HPM board.

Pressure Below Lower Limit

The system pressure has fallen below the lower pressure limit.

Probable Causes

- Lower pressure limit set too high.
- Air bubbles in the mobile phase.
- Leak.
- Defective damper.
- Defective HPM board.

Suggested Actions

- Ensure the lower pressure limit is set to a value suitable for the analysis.
- Ensure solvents are degassed. Purge the binary pump.
- Ensure solvent inlet filters are not blocked.
- Inspect the pump head, capillaries and fittings for signs of a leak.
- Purge the binary pump. Run a pressure test to determine whether the seals or other pump components are defective.
- Exchange the damper.
- Exchange the HPM board.

Pressure Signal Missing

The pressure signal from the damper is missing.

The pressure signal from the damper must be within a specific voltage range. If the pressure signal is missing, the processor detects a voltage of approximately -120mV across the damper connector.

Probable Causes

- Damper disconnected.
- Defective damper.

Suggested Actions

- Ensure the damper is connected correctly to the HPM board.
- Exchange the damper.

Valve Failed

Valve 0 Failed: valve A1

Valve 1 Failed: valve A2

Valve 2 Failed: valve B2

Valve 3 Failed: valve B1

One of the solvent selection valves in the binary pump failed to switch correctly.

The processor monitors the valve voltage before and after each switching cycle. If the voltages are outside expected limits, the error message is generated.

Probable Causes

- Solvent selection valve disconnected.
- Connection cable (inside instrument) not connected.
- Connection cable (inside instrument) defective.
- Solvent selection valve defective.

Suggested Actions

- Ensure the solvent selection valve is connected correctly.
- Ensure the connection cable is connected correctly.
- Exchange the connection cable.
- Exchange the solvent selection valve.

Missing Pressure Reading

The pressure readings read by the pump ADC (analog-digital converter) are missing.

The ADC reads the pressure readings from the damper every 1ms. If the readings are missing for longer than 10 seconds, the error message is generated.

Probable Causes

- Damper not connected.
- Defective damper.
- Defective HPM board.

Suggested Actions

- Ensure the damper connector is clean, and seated correctly.
- Exchange the damper.
- Exchange the HPM board.

Pump Configuration

At switch-on, the pump has recognized a new pump configuration.

The binary pump is assigned its configuration at the factory. If the active-inlet valve and pump encoder of channel B are disconnected, and the binary pump is rebooted, the error message is generated. *However, the binary pump will function as an isocratic pump in this configuration.* The error message reappears after each switch-on.

Probable Causes

- Active-inlet valve and pump encoder of channel B disconnected.

Suggested Actions

- Reconnect the active-inlet valve and pump encoder of channel B.

Valve Fuse

Valve Fuse 0: Channels A1 and A2

Valve Fuse 1: Channels B1 and B2

One of the solvent-selection valves in the binary pump has drawn excessive current causing the selection-valve electronic fuse to open.

Probable Causes

- Defective solvent selection valve.
- Defective connection cable (front panel to HPM board).
- Defective HPM board.

Suggested Actions

- Restart the binary pump. If the error message appears again, exchange the solvent selection valve.
- Exchange the connection cable.
- Exchange the HPM board.

Inlet-Valve Fuse

Inlet-Valve Fuse 0: Pump channel A

Inlet-Valve Fuse 1: Pump channel B

One of the active-inlet valves in the binary pump has drawn excessive current causing the inlet-valve electronic fuse to open.

Probable Causes

- Defective active inlet valve.
- Defective connection cable (front panel to HPM board).
- Defective HPM board.

Suggested Actions

- Restart the binary pump. If the error message appears again, exchange the active inlet valve.
- Exchange the connection cable.
- Exchange the HPM board.

Temperature Out of Range

Temperature Out of Range 0: Pump channel A

Temperature Out of Range 1: Pump channel B

One of the temperature sensor readings in the motor-drive circuit are out of range.

The values supplied to the ADC by the hybrid sensors must be between 0.5 V and 4.3 V. If the values are outside this range, the error message is generated.

Probable Causes

- Defective HPM board.

Suggested Actions

- Exchange the HPM board.

Temperature Limit Exceeded

Temperature Limit Exceeded 0: Pump channel A

Temperature Limit Exceeded 1: Pump channel B

The temperature of one of the motor-drive circuits is too high.

The processor continually monitors the temperature of the drive circuits on the HPM board. If excessive current is being drawn for long periods, the temperature of the circuits increase. If the temperature exceeds the upper limit of 95 °C, the error message is generated.

Probable Causes

- High friction (partial mechanical blockage) in the pump drive assembly.
- Partial blockage of the flowpath in front of the damper.
- Defective drive assembly.
- Defective HPM board.

Suggested Actions

- Ensure the capillaries and frits between the pump head and damper inlet are free from blockage.
- Ensure the outlet valve is not blocked.
- Remove the pump head assembly. Ensure there is no mechanical blockage of the pump head assembly or pump drive assembly.
- Exchange defective drive assembly.
- Exchange the HPM board.

Motor-Drive Power

Motor-Drive Power: Pump channel A

B: Motor-Drive Power: Pump channel B

The current drawn by the pump motor exceeded the maximum limit.

Blockages in the flowpath are usually detected by the pressure sensor in the damper, which result in the binary pump switching off when the upper pressure limit is exceeded. If a blockage occurs before the damper (i.e. the pressure increase cannot be detected by the pressure sensor), the binary pump will continue to pump. As pressure increases, the pump drive draws more current. When the current reaches the maximum limit, the binary pump is switched off, and the error message is generated.

Probable Causes

- Flow path blockage in front of the damper.
- Blocked outlet ball valve.
- High friction (partial mechanical blockage) in the drive assembly.
- Defective drive assembly.
- Defective HPM board.

Suggested Actions

- Ensure the capillaries and frits between the pump head and damper inlet are free from blockage.
- Exchange the outlet ball valve.
- Remove the pump head assembly. Ensure there is no mechanical blockage of the pump head assembly or drive assembly.
- Exchange the drive assembly.
- Exchange the HPM board.

Encoder Missing

Encoder Missing: Pump channel A

B: Encoder Missing: Pump channel B

The optical encoder on the pump motor in the binary pump is missing or defective.

The processor checks the presence of the pump encoder connector every 2 seconds. If the connector is not detected by the processor, the error message is generated.

Probable Causes

- Defective or disconnected pump encoder connector.
- Defective pump drive assembly.

Suggested Actions

- Ensure the connector is clean, and seated correctly.
- Exchange the pump drive assembly.

Inlet-Valve Missing

Inlet-Valve Missing: Pump channel A

B: Inlet-Valve Missing: Pump channel B

The active-inlet valve in the binary pump is missing or defective.

The processor checks the presence of the active-inlet valve connector every 2 seconds. If the connector is not detected by the processor, the error message is generated.

Probable Causes

- Disconnected or defective cable.
- Disconnected or defective connection cable (front panel to HPM board).
- Defective active inlet valve.

Suggested Actions

- Ensure the pins of the active inlet valve connector are not damaged. Ensure the connector is seated securely.
- Ensure the connection cable is seated correctly. Exchange the cable if defective.
- Exchange the active inlet valve.

Servo Restart Failed

Servo Restart Failed: Pump channel A

B: Servo Restart Failed: Pump channel B

The pump motor in the binary pump was unable to move into the correct position for restarting.

When the binary pump is switched on, the first step is to switch on the C phase of the variable reluctance motor. The rotor should move to one of the C positions. The C position is required for the servo to be able to take control of the phase sequencing with the commutator. If the rotor is unable to move, or if the C position cannot be reached, the error message is generated.

Probable Causes

- Disconnected or defective cables.
- Mechanical blockage of the binary pump.
- Defective pump drive assembly.
- Defective HPM board.

Suggested Actions

- Ensure the pump assembly cables are not damaged or dirty. Make sure the cables are connected securely to the HPM board.
- Remove the pump-head assembly. Ensure there is no mechanical blockage of the pump-head assembly or pump drive assembly.
- Exchange the pump drive assembly.
- Exchange the HPM board.

Pump Head Missing

Pump Head Missing: Pump channel A

B: Pump Head Missing: Pump channel B

The pump-head end stop in the binary pump was not found.

When the binary pump restarts, the metering drive moves forward to the mechanical end stop. Normally, the end stop is reached within 20 seconds, indicated by an increase in motor current. If the end point is not found within 20 seconds, the error message is generated.

Probable Causes

- Pump head not installed correctly (screws not secured, or pump head not seated correctly).
- Broken plunger.

Suggested Actions

- Install the pump head correctly. Ensure nothing (e.g. capillary) is trapped between the pump head and body.
- Exchange the plunger.

Index Limit

Index Limit: Pump channel A

B: Index Limit: Pump channel B

The time required by the plunger to reach the encoder index position was too short (binary pump).

During initialization, the first plunger is moved to the mechanical stop. After reaching the mechanical stop, the plunger reverses direction until the encoder index position is reached. If the index position is reached too fast, the error message is generated.

Probable Causes

- Irregular or sticking drive movement.
- Defective pump drive assembly.

Suggested Actions

- Remove the pump head, and examine the seals, plungers, and internal components for signs of wear, contamination or damage. Exchange components as required.
- Exchange the pump drive assembly.

Index Adjustment

Index Adjustment : Pump channel A

B: Index Adjustment: Pump channel B

The encoder index position in the binary pump is out of adjustment.

During initialization, the first plunger is moved to the mechanical stop. After reaching the mechanical stop, the plunger reverses direction until the encoder index position is reached. If the time to reach the index position is too long, the error message is generated.

Probable Causes

- Irregular or sticking drive movement.
- Defective pump drive assembly.

Suggested Actions

- Remove the pump head, and examine the seals, plungers, and internal components for signs of wear, contamination or damage. Exchange components as required.
- Exchange the pump drive assembly.

Index Missing

Index Missing: Pump channel A

B: Index Missing: Pump channel B

The encoder index position in the binary pump was not found during initialization.

During initialization, the first plunger is moved to the mechanical stop. After reaching the mechanical stop, the plunger reverses direction until the encoder index position is reached. If the index position is not recognized within a defined time, the error message is generated.

Probable Causes

- Disconnected or defective encoder cable.
- Defective pump drive assembly.

Suggested Actions

- Ensure the encoder cable are not damaged or dirty. Make sure the cables are connected securely to the HPM board.
- Exchange the pump drive assembly.

Stroke Length

Stroke Length: Pump channel A

B: Stroke Length: Pump channel B

The distance between the lower plunger position and the upper mechanical stop is out of limits (binary pump).

During initialization, the binary pump monitors the drive current. If the plunger reaches the upper mechanical stop position before expected, the motor current increases as the binary pump attempts to drive the plunger beyond the mechanical stop. This current increase causes the error message to be generated.

Probable Causes

- Defective pump drive assembly.

Suggested Actions

- Exchange the pump drive assembly.

Initialization Failed

Initialization Failed: Pump channel A

B: Initialization Failed: Pump channel B

The binary pump failed to initialize successfully within the maximum time window.

A maximum time is assigned for the complete pump-initialization cycle. If the time is exceeded before initialization is complete, the error message is generated.

Probable Causes

- Blocked active inlet valve.
- Defective pump drive assembly.
- Defective HPM board.

Suggested Actions

- Exchange the active inlet valve.
- Exchange the pump drive assembly.
- Exchange the HPM board.

Wait Timeout

When running certain tests in the diagnostics mode or other special applications, the pump must wait for the plungers to reach a specific position, or must wait for a certain pressure or flow to be reached. Each

action or state must be completed within the timeout period, otherwise the error message is generated.

Possible Reasons for a Wait Timeout

- Pressure not reached.
- Pump channel A did not reach the delivery phase.
- Pump channel B did not reach the delivery phase.
- Pump channel A did not reach the take-in phase.
- Pump channel B did not reach the take-in phase.
- Solvent volume not delivered within the specified time.

Probable Causes

- Purge valve still open.
- Leak at fittings, purge valve, active inlet valve, outlet ball valve or plunger seals.
- Flow changed after starting test.
- Defective pump drive assembly.

Suggested Actions

- Ensure that purge valve is closed.
- Exchange defective capillaries.
- Ensure pump components are seated correctly. If there are still signs of a leak, exchange the appropriate seal (purge valve, active inlet valve, outlet ball valve, plunger seal).
- Ensure correct operating condition for the special application in use.
- Exchange the defective pump drive assembly.

Pressure Test

Description

The pressure test is a quick, built-in test designed to demonstrate the pressure-tightness of the system. The test should be used when problems with small leaks are suspected, or after maintenance of flow-path components (e.g., pump seals, injection seal) to prove pressure tightness up to 400 bar. The test involves monitoring the pressure profile as the binary pump runs through a predefined pumping sequence. The resulting pressure profile provides information about the pressure tightness of the system.

The column compartment outlet (or the outlet of the last module before the detector) is blocked with a blank nut, and then the test is run using isopropyl alcohol (IPA), while monitoring the pressure profile (using an integrator on the analog output, or in the plot screen in the ChemStation). The pressure profile is shown in Figure 10.

Figure 10

Typical Pressure-Test Pressure Profile with IPA

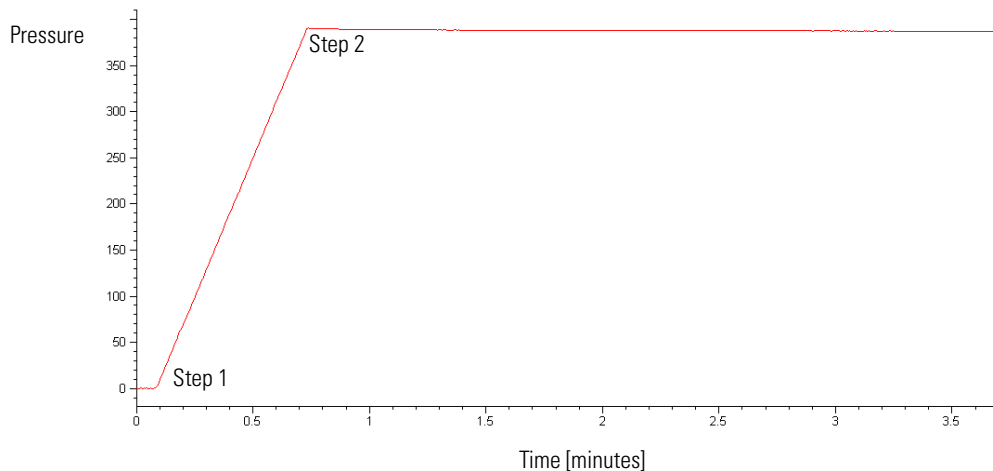

Step 1

The test begins with the initialization of both pumpheads. After initialization, plungers A1 and B1 are both at the top of their stroke. Next, pump A begins pumping solvent with a flow rate of 510 µl/min and stroke of 100 µl. The binary pump continues to pump until a system pressure of 390 bar is reached.

NOTE

For this test only channel A is active. To test the pressure tightness of the pump use the leak test, see “Leak Test” on page 91.

Step 2

When the system pressure reaches 390 bar, the binary pump switches off. The pressure drop from this point onwards should be no more than 2 bar/minute.

Positioning the blank nut

To test the complete system pressure tightness, the blank nut should be positioned at the column compartment outlet (or the outlet of the last module before the detector).

If a specific component is suspected of causing a system leak, place the blank nut immediately before the suspected component, then run the pressure test again. If the test passes, the defective component is located after the blank nut. Confirm the diagnosis by placing the blank nut immediately after the suspected component. The diagnosis is confirmed if the test fails.

Running the Pressure Test

Tools required	Wrench 1/4 inch.
Parts and materials required	Blank nut, 01080-83202 Isopropanol, 500 ml

NOTE

Make absolutely sure that all parts of the flow path that are part of the test are very thoroughly flushed with IPA before starting to pressurize the system! Any trace of other solvents or the smallest air bubble inside the flow path definitely will cause the test to fail!

Running the test from the ChemStation

- 1 Select the pressure test from the test selection box in the Diagnosis screen.
- 2 Start the test and follow the instructions.

The slope and plateau is evaluated automatically. “Evaluating the Results” on page 89 describes the evaluation and interpretation of the pressure test results.

Running the test from the Control Module

- 1 Place a bottle of LC-grade isopropyl alcohol in the solvent cabinet and connect it to channel A (or channel A2 if solvent selection valve is installed).
- 2 Block column compartment outlet (or the outlet of the last module before the detector) with a blank nut (01080-83202), See “Positioning the blank nut” on page 86.
- 3 Open the purge valve.
- 4 For binary pumps with degasser set flow for channel A or A2 to 5 ml/min and flush the degasser channel for about 10 minutes.

Running the Pressure Test

- 5 For binary pumps without degasser set flow for channel A or A2 to 5 ml/min and flush pump head A for about 2 minutes.
- 6 Set flow to 0 ml/min. *Leave the purge valve open.*
- 7 Connect the signal cable to the analog output at the rear of the binary pump (only if an integrator is used).
- 8 Press Execute to initialize the pressure test.

Once the test is started, the binary pump moves the plungers into the start position. When the plungers are in position, the user interface prompts you to close the purge valve, and continue the test.

- 9 Close the purge valve, select *continue* on the control module and press *Enter* to start the test.

The control module displays a graphical representation of the pressure. “Evaluating the Results” on page 89 describes the evaluation and interpretation of the pressure test results.

- 10 When the test is finished slowly open the purge valve to release the pressure in the system.

Evaluating the Results

The sum of all leaks between the pump and the blank nut will be indicated by a pressure drop of >2 bar/minute at the plateau. Note that small leaks may cause the test to fail, but solvent may not be seen leaking from a module.

NOTE

Please notice the difference between an **error** in the test and a **failure** of the test! An **error** means that during the operation of the test there was an abnormal termination. If a test **failed**, this means that the results of the test were not within the specified limits.

If the pressure test fails:

- Ensure all fittings between the pump and the blank nut are tight. Repeat the pressure test.

NOTE

Often it is only a damaged blank nut itself (poorly shaped from overtightening) that causes a failure of the test. Before investigating on any other possible sources of failure make sure that the blank nut you are using is in good condition and properly tightened!

- If the test fails again, insert the blank nut at the outlet of the previous module in the stack (eg. autosampler, port 6 of the injection valve), and repeat the pressure test. Exclude each module one by one to determine which module is leaking.
- If the pump is determined to be the source of the leak, run the leak test.

Evaluating the Results

Potential Causes of Pressure Test Failure

After isolating and fixing the cause of the leak, repeat the pressure test to confirm the system is pressure tight.

Potential Cause (Pump)	Corrective Action
Purge valve open.	Close the purge valve.
Loose or leaky fitting.	Tighten the fitting or exchange the capillary.
Damaged pump seals or plungers.	Run the leak test to confirm the leak.
Loose purge valve.	Tighten the purge valve nut (14 mm wrench).

Potential Cause (Autosampler)	Corrective Action
Loose or leaky fitting.	Tighten or exchange the fitting or capillary.
Rotor seal (injection valve).	Exchange the rotor seal.
Damaged metering seal or plunger.	Exchange the metering seal. Check the plunger for scratches. Exchange the plunger if required.
Needle seat.	Exchange the needle seat.

Potential Cause (Column Compartment)	Corrective Action
Loose or leaky fitting.	Tighten or exchange the fitting or capillary.
Rotor seal (column switching valve).	Exchange the rotor seal.

Leak Test

The leak test is a built-in troubleshooting test designed to demonstrate the leak-tightness of the binary pump. The test should be used when problems with the binary pump are suspected. The test involves monitoring the pressure profile as the binary pump runs through a predefined pumping sequence. The resulting pressure profile provides information about the pressure tightness and operation of the binary pump components.

Description

The pump outlet is blocked with a blank nut, and then the test is run using isopropyl alcohol (IPA), while monitoring the pressure profile (using an integrator on the analog output, or in the plot screen in the Control Module or the ChemStation). The pressure profile is shown in Figure 11.

Figure 11 Typical Leak-Test Pressure Profile with IPA

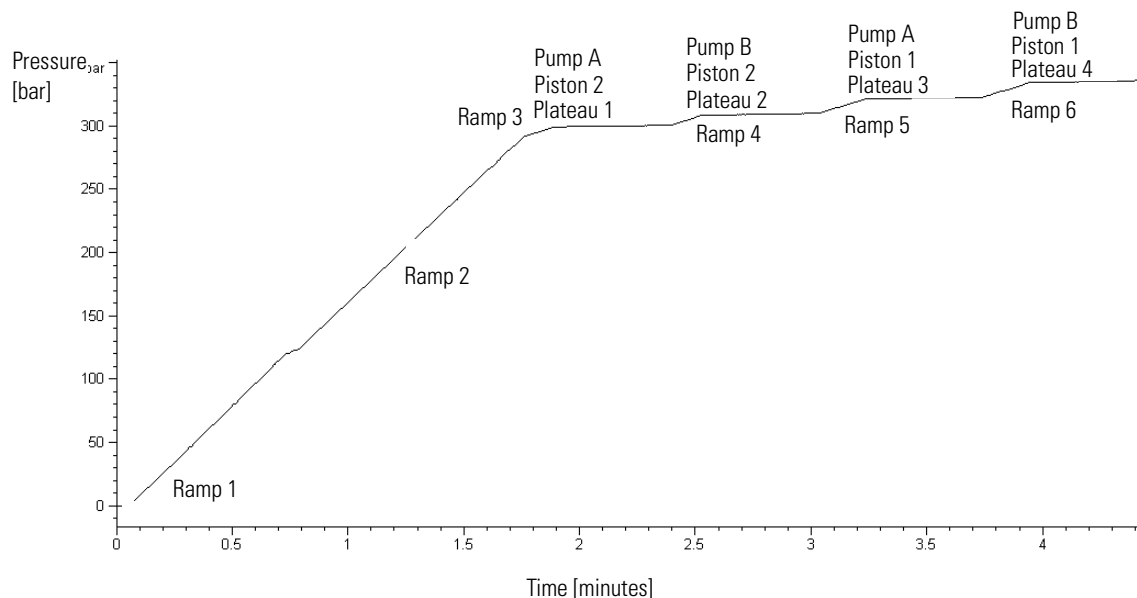

Ramp 1

The test begins with the initialization of both pumps. After initialization, plungers A1 and B1 are both at the top of their stroke. Next, the binary pump begins pumping solvent with a flow rate of 150 $\mu\text{l}/\text{min}$, stroke of 100 μl , and a composition of 51 %A, 49 %B. Both pumps deliver for one complete pump cycle. At the end of this step, plungers A1 and B1 are at the top of their stroke.

Ramp 2

The binary pump continues pumping solvent with a flow rate of 150 $\mu\text{l}/\text{min}$. Channel A delivers for one pump cycle (first, plunger A2 delivers, then plunger A1), followed by channel B (plunger B2, then plunger B1), both channels with a stroke of 20 μl . The pressure increase during this phase

Description

should be linear. Large leaks or defects will be characterized by an unstable, non-linear slope.

Ramp 3

Just before the start of the first plateau, plunger A2 delivers with a flow rate of 50 $\mu\text{l}/\text{min}$ for approximately 8 seconds. The system pressure should be 240 bar or higher.

Plateau 1

At plateau 1 plunger A2 delivers with a flow rate of 3 $\mu\text{l}/\text{min}$ for 30 seconds. During this time, the slope should be horizontal or slightly positive (slight pressure increase). A negative slope indicates a leak rate greater than 3 $\mu\text{l}/\text{min}$.

Ramp 4

Plunger B2 delivers 50 $\mu\text{l}/\text{min}$ for approximately 8 seconds.

Plateau 2

Plunger B2 delivers with a flow rate of 3 $\mu\text{l}/\text{min}$ for 30 seconds. The slope should be horizontal or slightly positive. A negative slope indicates a leak rate greater than 3 $\mu\text{l}/\text{min}$.

Ramp 5

Plunger A1 delivers 50 $\mu\text{l}/\text{min}$ for approximately 8 seconds.

Plateau 3

Plunger A1 with a flow rate of 3 $\mu\text{l}/\text{min}$ for 30 seconds. The slope should be horizontal or slightly positive. A negative slope indicates a leak rate greater than 3 $\mu\text{l}/\text{min}$.

Ramp 6

Plunger B1 delivers 50 $\mu\text{l}/\text{min}$ for approximately 7 seconds.

Plateau 4

Plunger B1 delivers with a flow rate of 3 $\mu\text{l}/\text{min}$ for approximately 30 seconds. The slope should be horizontal or slightly positive. A negative slope indicates a leak rate greater than 3 $\mu\text{l}/\text{min}$. At the end of the fourth plateau, the test is finished and the binary pump switches off.

Running the Leak Test

Tools required	Wrench 1/4 inch
Parts and materials required	Restriction Capillary ,G1313-87305 Blank nut, 01080-83202 Isopropanol, 500ml

NOTE **Make absolutely sure that all parts of the flow path that are part of the test are very thoroughly flushed with IPA before starting to pressurize the system! Any trace of other solvents or the smallest air bubble inside the flow path definitely will cause the test to fail!**

The slopes and plateaus are evaluated automatically. “Evaluating the Results” on page 96 describes the evaluation and interpretation of the leak test results.

Running the test from the ChemStation

- 1 Select the leak test from the test selection box in the Diagnosis screen.
- 2 Start the test and follow the instructions.

Running the test from the Control Module

- 1 Place two bottles of LC-grade isopropyl alcohol in channels A and B. If a solvent selection valve is installed, place the LC grade isopropanol in channels A2 and B2.
- 2 Open the purge valve.

Binary Pumps with Degasser

- 3 Set flow to 5 ml/min for channel A or A2 and flush the degasser for about 10 minutes.
- 4 Set flow to 5 ml/min for channel B or B2 and flush the degasser for about 10 minutes.

Running the Leak Test

Binary Pumps without Degasser

- 5 Set Flow to 5 ml/min for channel A or A2 and flush pump head A for about 2 minutes.
- 6 Set Flow to 5 ml/min for channel B or B2 and flush pump head B for about 2 minutes.
- 7 Turn off pump operation and close the purge valve.
- 8 Connect the restriction capillary (G1313-87305) to pump outlet.
The next steps are necessary to wear in new seals.
- 9 Set flow to 5 ml/min and %B to 50 and flush pump channels for about 3 minutes.
- 10 Set flow to 0 ml/min and replace the restriction capillary with blank nut (01080-83202).
- 11 Open the purge valve.
- 12 Connect the signal cable to the analog output at the rear of the binary pump (only if an integrator is used).
- 13 Press Execute to initialize the leak test.
Once the test is started, the binary pump moves the plungers into the start position. When the plungers are in position, the user interface prompts you to close the purge valve, and continue the test.
- 14 Close the purge valve, select *continue* on the control module and press *Enter* to start the test.
The control module displays a graphical representation of the pressure in the plateau windows. “Evaluating the Results” on page 96 describes the evaluation and interpretation of the leak test results.
- 15 When the test is finished slowly open the purge valve to release the pressure in the system.

Evaluating the Results

Defective or leaky components in the pump head lead to changes in the leak-test pressure plot. Typical failure modes are described below.

Figure 12

Leak Test Pressure Plot

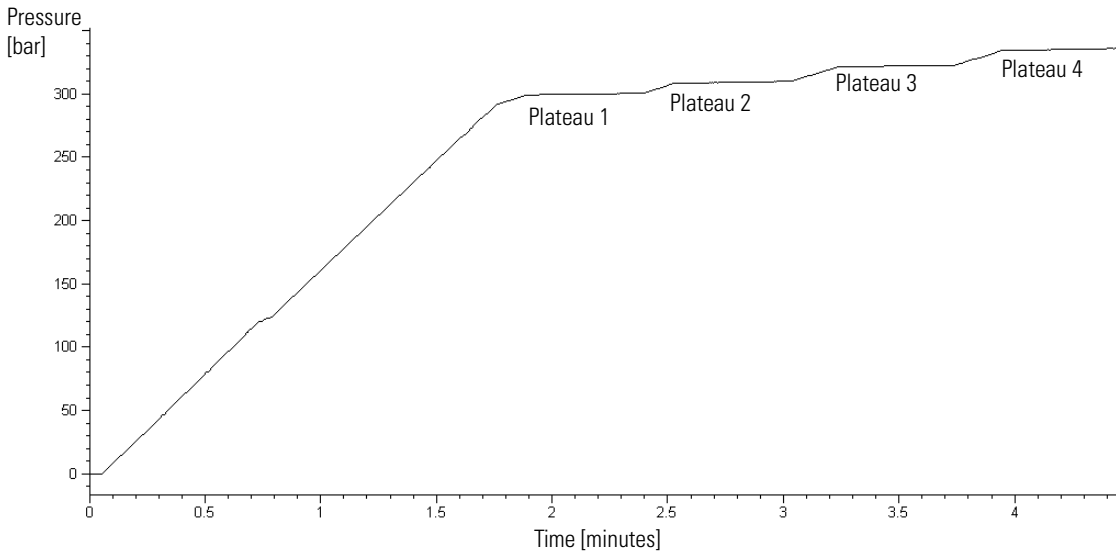

NOTE

Please notice the difference between an **error** in the test and a **failure** of the test! An **error** means that during the operation of the test there was an abnormal termination. If a test **failed**, this means that the results of the test were not within the specified limits.

NOTE

Often it is only a damaged blank nut itself (poorly shaped from overtightening) that causes a failure of the test. Before investigating on any other possible sources of failure make sure that the blank nut you are using is in good condition and properly tightened!

Evaluating the Results

NOTE

The pressure plots shown below are examples only. The plots may vary depending on the type and degree of leakage.

No pressure increase or minimum pressure of plateau 1 not reached

Potential Cause	Corrective Action
Pump not running.	Check the logbook for error messages.
Purge valve open.	Close the purge valve, and restart the test.
Wrong solvent-line connections to solvent selection valve.	Ensure the solvent lines from the degasser to the solvent selection valve are connected correctly.
Loose or leaky fittings.	Ensure all fittings are tight, or exchange capillary.
Large leaks (visible) at the pump seals.	Exchange the pump seals.
Large leaks (visible) at active inlet valve, outlet valve, or purge valve.	Ensure the leaky components are installed tightly. Exchange the component if required.

Pressure limit not reached but plateaus horizontal or positive

Potential Cause	Corrective Action
Degasser and pump channels A and/or B not flushed sufficiently (air in the channels).	Purge the degasser and pump channels thoroughly with isopropanol under pressure (use the restriction capillary).
Wrong solvent.	Install isopropanol. Purge the degasser and pump channels thoroughly.

Evaluating the Results

All plateaus negative

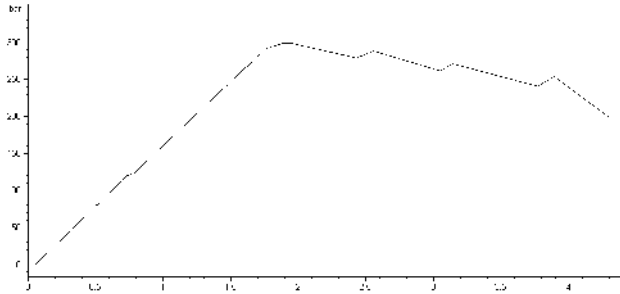

Potential Cause	Corrective Action
Loose or leaky fittings.	Ensure all fittings are tight, or exchange capillary.
Loose purge valve.	Tighten the purge valve (14mm wrench).
Leaky mixer (if installed).	Tighten the mixer fittings and nuts.
Contaminated purge valve.	Open and close purge valve to flush out contamination. Exchange the valve if still leaky.
Loose pump head screws in channel A or B.	Ensure the pump head screws in channels A and B are tight.
Leaking seal or scratched plunger in channel A2 or B2.	Exchange the pump seals in both channels. Check the plungers for scratches. Exchange if scratched.
Leaking outlet valve in channel A or B.	Exchange the outlet valve.
Leaky damper.	Exchange damper.

Evaluating the Results

First plateau negative or unstable, and at least one other plateau positive.

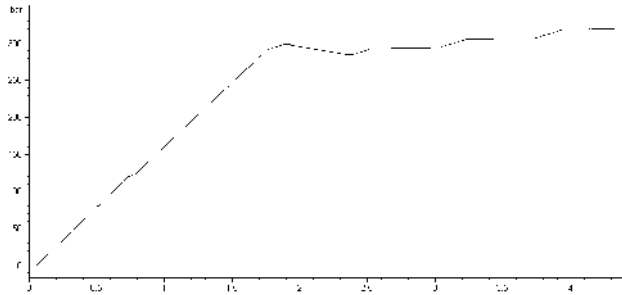

Potential Cause	Corrective Action
Leaking outlet valve in channel A.	Clean the outlet valve in channel A. Ensure the sieve in the outlet valves are installed correctly. Tighten the outlet valve.
Loose pump head screws in channel A.	Ensure the pump head screws in channel A are tight.
Leaking seal or scratched plunger in channel A2.	Exchange the pump seals in channel A. Check the plunger for scratches. Exchange if scratched.

Evaluating the Results

Second plateau negative or unstable, and at least one other plateau positive

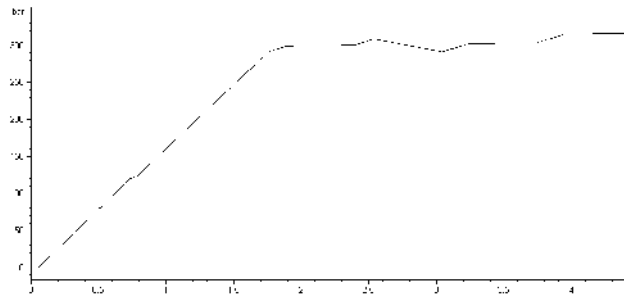

Potential Cause	Corrective Action
Leaking outlet valve in channel B.	Clean the outlet valve in channel B. Ensure the sieve in the outlet valves are installed correctly. Tighten the outlet valve.
Loose pump head screws in channel B.	Ensure the pump head screws in channel B are tight.
Leaking seal or scratched plunger in channel B2.	Exchange the pump seals in channel B. Check the plunger for scratches. Exchange if scratched.

Evaluating the Results

Third plateau negative or unstable and at least one other plateau positive

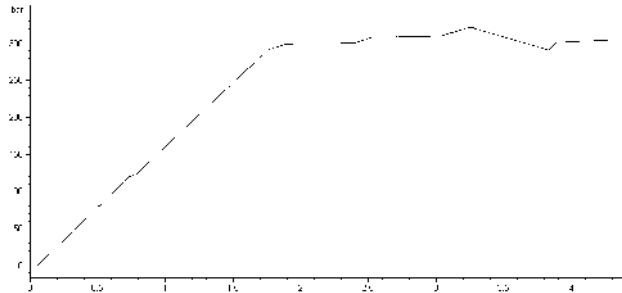

Potential Cause	Corrective Action
Air in channel A or new seals not yet seated.	Flush channel A thoroughly with isopropanol under pressure (use restriction capillary).
Loose active inlet valve in channel A.	Tighten the active inlet valve in channel A (14mm wrench). Do not overtighten!
Loose pump head screws in channel A.	Ensure the pump head screws in channel A are tight.
Loose outlet valve in channel A.	Ensure the sieve in the outlet valve is installed correctly. Tighten the outlet valve.
Leaking seal or scratched plunger in channel A1.	Exchange the pump seals in channel A. Check the plungers for scratches. Exchange if scratched.
Defective active inlet valve in channel A.	Exchange the active inlet valve in channel A.

Evaluating the Results

Fourth plateau negative or unstable and at least one other plateau positive

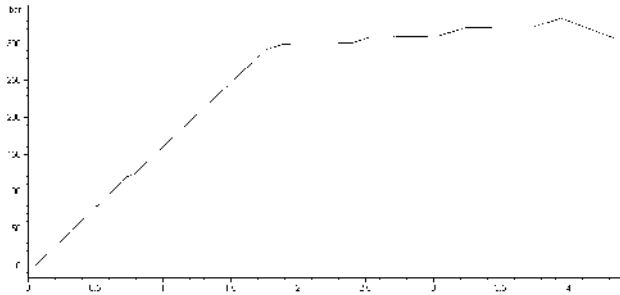

Potential Cause	Corrective Action
Air in pump chamber of channel B or seals not yet seated.	Flush channel B thoroughly with isopropanol under pressure (restriction capillary).
Loose active inlet valve in channel B.	Tighten the active inlet valve in channel B (14mm wrench). Do not overtighten!
Loose pump head screws in channel B.	Ensure the pump head screws in channel B are tight.
Loose outlet valve in channel B.	Ensure the sieve in the outlet valve is installed correctly. Tighten the outlet valve.
Leaking seal or scratched plunger in channel B1.	Exchange the pump seals in channel B. Check the plungers for scratches. Exchange if scratched.
Defective active inlet valve in channel B.	Exchange the active inlet valve in channel B.

Repairing the Pump

Instructions on simple, routine repair procedures as well as more extensive repairs requiring exchange of internal parts

Repairing the Pump

Simple Repairs

The binary pump is designed for easy repair. The most frequent repairs such as plunger seal change and purge valve frit change can be done from the front of the binary pump with the binary pump in place in the system stack. These repairs are described in “Simple Repair Procedures” on page 108.

WARNING

When opening capillary or tube fittings solvents may leak out. Please observe appropriate safety procedures (for example, goggles, safety gloves and protective clothing) as described in the material handling and safety data sheet supplied by the solvent vendor, especially when toxic or hazardous solvents are used.

Exchanging Internal Parts

Some repairs may require exchange of defective internal parts. Exchange of these parts requires removing the binary pump from the stack, removing the covers, and disassembling the binary pump. The security lever at the power input socket prevents that the pump cover is taken off when line power is still connected.

WARNING

To prevent personal injury, the power cable must be removed from the binary pump before opening the cover. Do not connect the power cable to the binary pump while the covers are removed.

CAUTION

Electronic boards and components are sensitive to electrostatic discharge (ESD). In order to prevent damage always use an ESD protection (for example, the ESD wrist strap from the accessory kit) when handling electronic boards and components.

Cleaning the Binary Pump

The binary pump case should be kept clean. Cleaning should be done with a soft cloth slightly dampened with water or a solution of water and a mild detergent. Do not use an excessively damp cloth that liquid can drip into the binary pump.

WARNING

Do not let liquid drip into the binary pump. It could cause shock hazard and it could damage the binary pump.

Using the ESD Strap

Electronic boards are sensitive to electrostatic discharge (ESD). In order to prevent damage, always use an ESD strap supplied in the standard accessory kit (see “Accessory Kit G1311-68705” on page 186) when handling electronic boards and components.

Using the ESD Strap

- 1 Unwrap the first two folds of the band and wrap the exposed adhesive side firmly around your wrist.
- 2 Unroll the rest of the band and peel the liner from the copper foil at the opposite end.
- 3 Attach the copper foil to a convenient and exposed electrical ground.

Figure 13

Using the ESD Strap

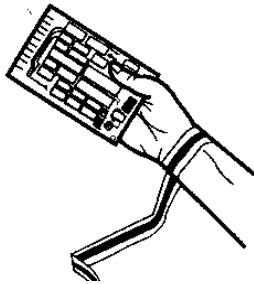

Overview

Figure 14 shows the main assemblies of the binary pump. The pump heads and its parts do require normal maintenance (for example, seal exchange) and can be accessed from the front (simple repairs). Replacing internal parts will require to remove the module from its stack and to open the top cover.

Figure 14 Overview of Repair Procedures

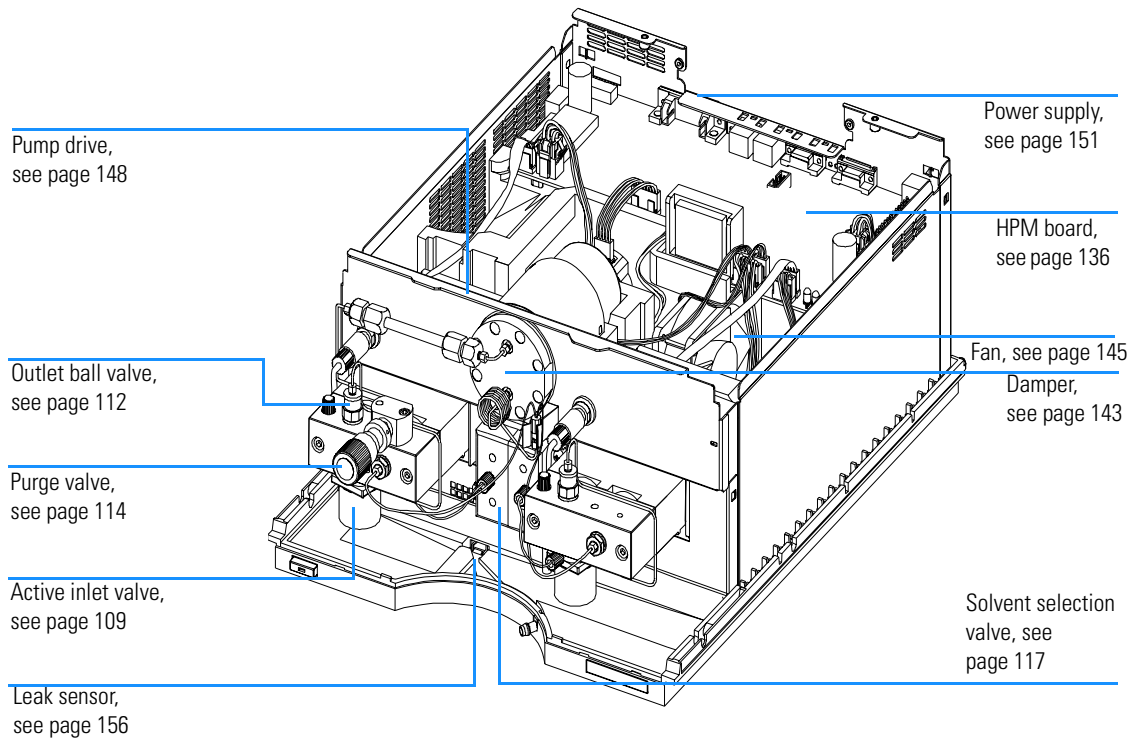

Simple Repair Procedures

The procedures described in this section can be done with the binary pump in place in the system stack.

Table 6 **Simple Repair Procedures**

Procedure	Typical Frequency	Notes
“Exchanging the Active Inlet Valve Cartridge or the Active Inlet Valve” on page 109	If internally leaking	Pressure ripple unstable, run leak test for verification
“Exchanging the Outlet Ball Valve Sieve or the Complete Valve” on page 112	If internally leaking	Pressure ripple unstable, run leak test for verification
“Exchanging the Purge Valve Frit or the Purge Valve” on page 114	If internally leaking	Solvent dripping out of waste outlet when valve closed
“Exchanging the Purge Valve Frit or the Purge Valve” on page 114	If the frit shows indication of contamination or blockage	A pressure drop of > 10 bar across the frit (5 ml/min H ₂ O with purge valve open) indicates blockage
“Exchanging the Pump Seals and Seal Wear-in Procedure” on page 121	If pump performance indicates seal wear	Leaks at lower pump head side, unstable retention times, pressure ripple unstable — run leak test for verification
“Exchanging the Plungers” on page 124	If scratched	Seal life time shorter than normally expected — check plungers while changing the seals
“Exchanging the Wash Seals” on page 127	When seals show indication of leaks	Leaks at lower pump head side, loss of wash solvent

Exchanging the Active Inlet Valve Cartridge or the Active Inlet Valve

When required	If internally leaking (backflow)
Tools required	Wrench 14 mm
Material	Active inlet valve G1312-60010 Valve Cartridge 5062-8562

Removing the Active Inlet Valve

- 1 Unplug the active inlet valve cable from the connector.
- 2 Disconnect the solvent inlet tube at the inlet valve. Beware of leaking solvents.

NOTE

Binary pumps without the solvent selection valve (SSV) have an adapter installed between the solvent line and the active inlet valve (AIV). Disconnect the solvent tubes at the adapter and remove the adapter from the AIV.

- 3 Using a 14-mm wrench loosen the active inlet valve and remove the valve from pump head.

Figure 15

Active Inlet Valve Parts

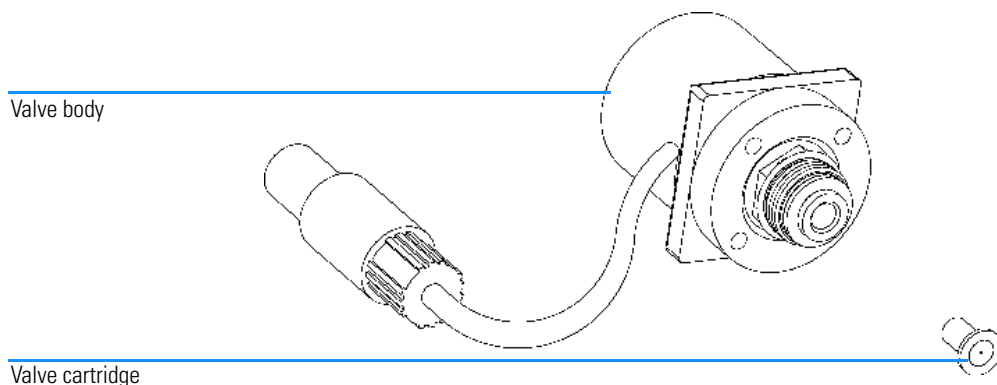

Exchanging the Valve Cartridge

- 1** Using a pair of tweezers remove the valve cartridge from the actuator assembly.
- 2** Before inserting the new valve cartridge clean the area in the actuator assembly. Fill a syringe with alcohol and flush the cartridge area thoroughly.
- 3** Insert a new valve cartridge into the actuator assembly. Make sure the valve cartridge is fully inserted into the actuator assembly.

Replacing the Active Inlet Valve

- 1** Insert the new valve into the pump head. Using the 14 mm wrench turn the nut until hand tight.
- 2** Position the valve that the solvent inlet tube connection points towards the front.
- 3** Using the 14 mm wrench tighten the nut by turning the valve in its final position (not more than a quarter turn). Do not overtighten the valve. The solvent inlet tube connection should point to the right corner of the pump head.

NOTE

For binary pumps without solvent selection valve replace the adapter to the active inlet valve.

- 4** Reconnect the inlet tube and the active inlet valve cable to the connector at the Z-panel.
- 5** After an exchange of the valve cartridge it may take several mL of pumping with the solvent used in the current application, before the flow stabilizes at a %-ripple as low as it used to be, when the system was still working properly.

Figure 16

Exchanging the Active Inlet Valve

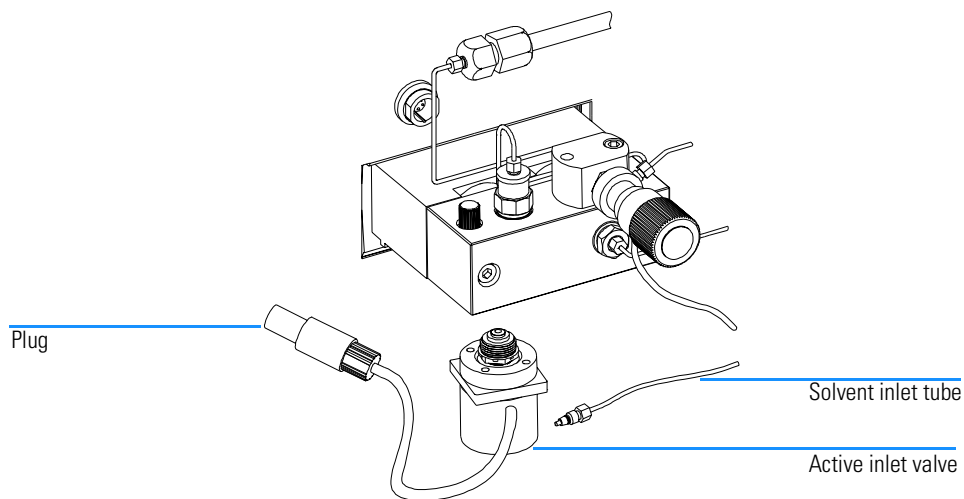

Exchanging the Outlet Ball Valve Sieve or the Complete Valve

When required	Sieve — whenever the pump seals will be exchanged Valve — if internally leaking
Tools required	Wrench 1/4 inch Wrench 14 mm
Parts required	Outlet ball valve G1312-60008 Sieve (pack of 10) 5063-6505

NOTE

Before exchanging the outlet ball valve you can try to clean it in a sonic bath. Remove the gold seal and the sieve. Place the valve in upright position (onto the plastic cap) in a small beaker with alcohol. Place in a sonic bath for 5 to 10 minutes. Insert a new sieve and replace the gold seal.

- 1 Using a 1/4 inch wrench disconnect the valve capillary from the outlet ball valve.
- 2 Using the 14 mm wrench loosen the valve and remove it from the pump body.
- 3 Remove the plastic cap with the gold seal from the outlet ball valve.
- 4 Using a pair of tweezers remove the sieve.

NOTE

Check the gold seal. It should be exchanged when strongly deformed. Place the valve in an upright position, insert the sieve into the recess and replace the gold seal with the cap. Make sure that the sieve cannot move and is away from the seal area of the gold seal.

- 5 Place a new sieve into the recess of the outlet ball valve and replace the cap with the gold seal.
- 6 Check that the new valve is assembled correctly and that the gold seal is present.

Figure 17

Outlet Ball Valve Parts

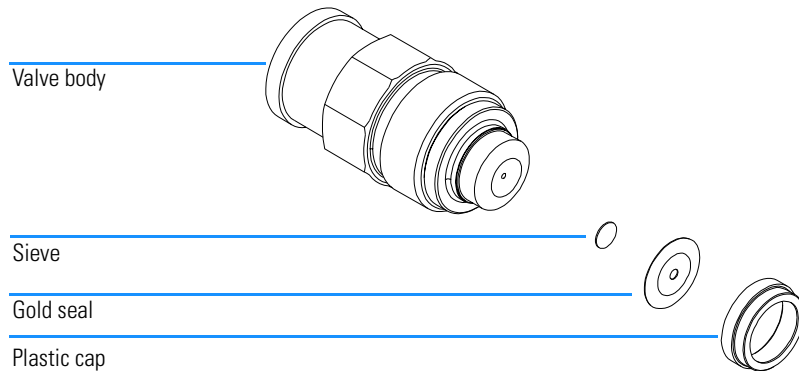

7 Reinstall the outlet ball valve and tighten the valve.

8 Reconnect the valve capillary.

Figure 18

Exchanging the Outlet Ball Valve

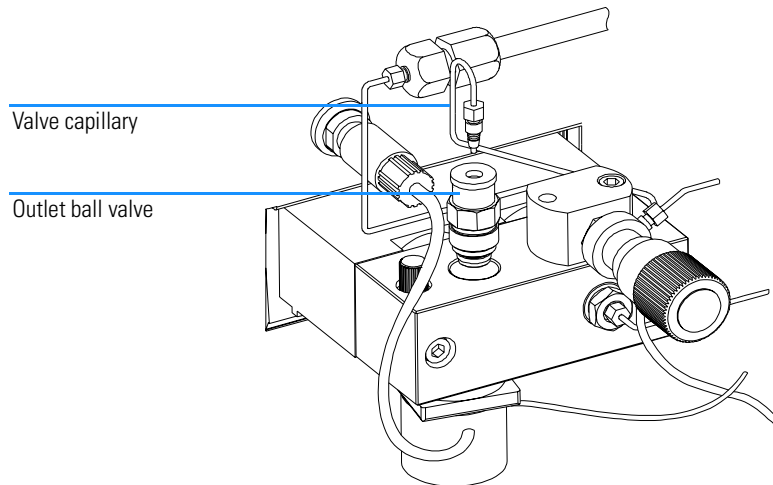

Exchanging the Purge Valve Frit or the Purge Valve

When required	Frit - when plunger seals are exchanged or when contaminated or blocked (pressure drop of > 10 bar across the frit at a flow rate of 5 ml/min of H ₂ O with purge valve opened) Purge valve - if internally leaking
Tools required	Wrench 1/4 inch Wrench 14 mm Pair of tweezers or toothpick
Parts required	PTFE Frit (pack of 5) 01018-22707 Purge valve G1311-60009

- 1** Using a 1/4 inch wrench disconnect the pump outlet capillary at the purge valve.
- 2** Disconnect the waste tube. Beware of leaking solvents due to hydrostatic pressure.
- 3** Using the 14 mm wrench unscrew the purge valve and remove it from the purge valve holder.
- 4** Remove the plastic cap with the gold seal from the purge valve.
- 5** Using a pair of tweezers or a toothpick remove the frit.

Figure 19

Purge Valve Parts

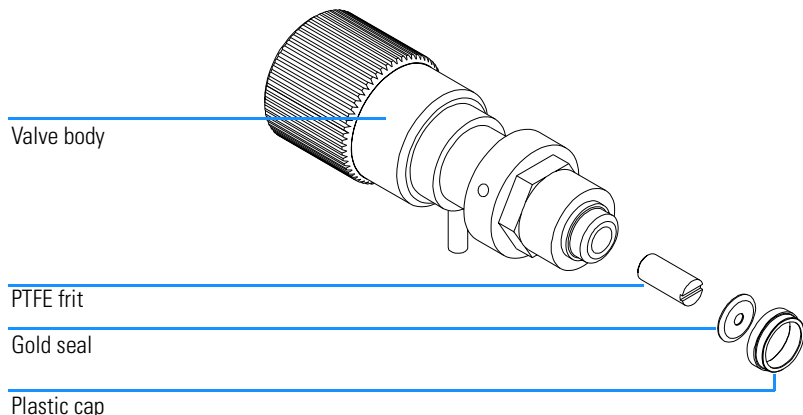

- 6 Place a new frit into the purge valve with the orientation of the frit as shown above.
- 7 Replace the cap with the gold seal.

NOTE

Before reinstallation always check the gold seal. A deformed seal should be exchanged.

- 8 Insert the purge valve into the purge valve holder and locate the pump outlet and the waste outlet as shown below.
- 9 Tighten the purge valve and reconnect outlet capillary and waste tubing.

Figure 20

Exchanging the Purge Valve Frit

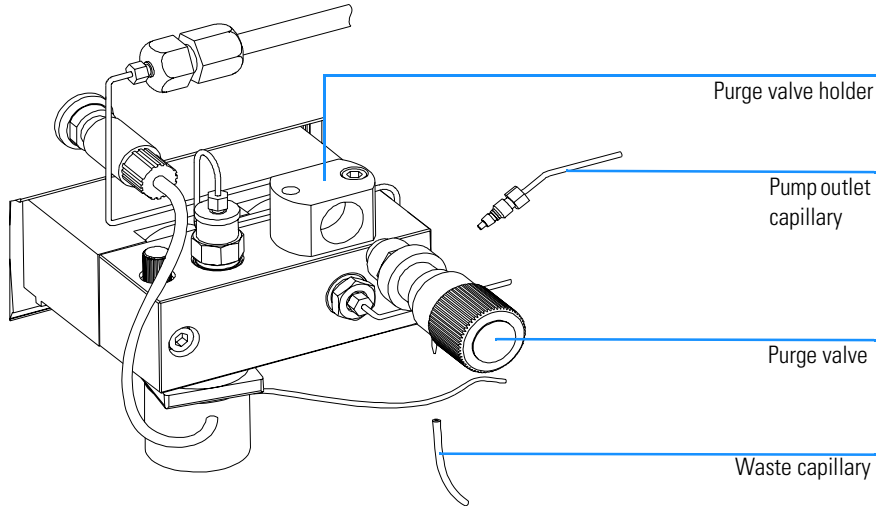

Exchanging the Solvent Selection Valve

When required	If internally leaking (crossflow between the ports), or if one of the channels is blocked
Tools required	Screwdriver Pozidriv #1
Parts required	Solvent selection valve (PN gives half of a complete solvent selection block) G1312-60000

- 1** Disconnect the solvent tubes and the active inlet valve connection tubes from the solvent selection valves. Place solvent tubes into the solvent cabinet to prevent leaks due to hydrostatic flow.
- 2** Using a Pozidriv screwdriver #1 loosen the holding screws of the valves.
- 3** Pull the valve module out of its connector.
- 4** Hold the two plastic bodies of the valves and pull the two solvent selection valves apart.
- 5** Exchange the defective solvent selection valve. Press the exchanged valve (new half) together with the properly working old half.
- 6** Connect the valve module to its electrical connectors and fix the assembly with the two holding screws.
- 7** Reinstall solvent tubes and the active inlet valve connection tubes

Repairing the Pump
Exchanging the Solvent Selection Valve

Figure 21 **Exchanging the solvent selection valve**

Solvent tubes

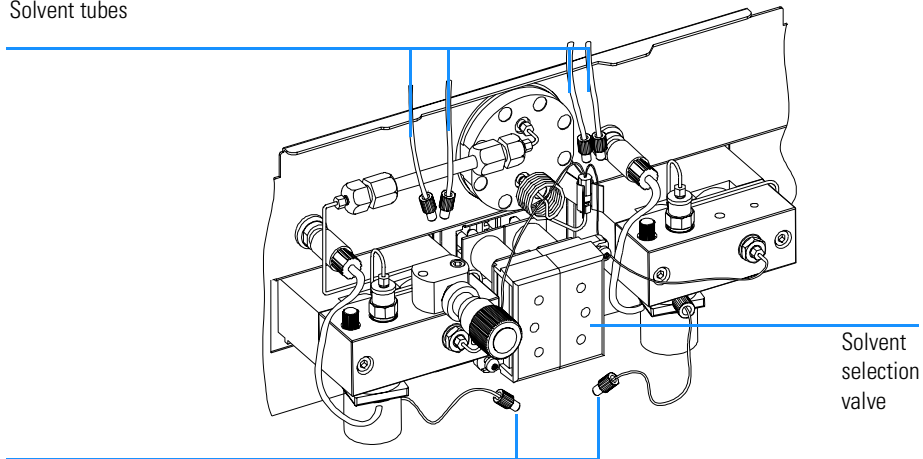

Connecting tubes

Solvent
selection
valve

Removing and Disassembling the Pump Head Assembly

WARNING

Never start the pump when the pump head is removed. This may damage the pump drive.

NOTE

Both pump head assemblies use the same internal components. In addition, pump head A is fitted with the purge valve and mixing junction. The following procedure describes the removal and disassembly of pump head A (left one). For pump head B (right one) proceed in the same way and skip steps that deal with the purge valve

When required:

- Exchanging the seals
- Exchanging the plungers
- Exchanging seals of the seal wash option

Tools required:

- Wrench 1/4 inch
- 3-mm hexagonal key
- 4-mm hexagonal key

Preparations for this procedure:

- Switch off binary pump at power switch
- Remove the front cover to have access to the pump mechanics

1 Disconnect the capillary at the pumphead adapter and the tube at the active inlet valve. Beware of leaking solvents. Disconnect the active inlet valve cable plug.

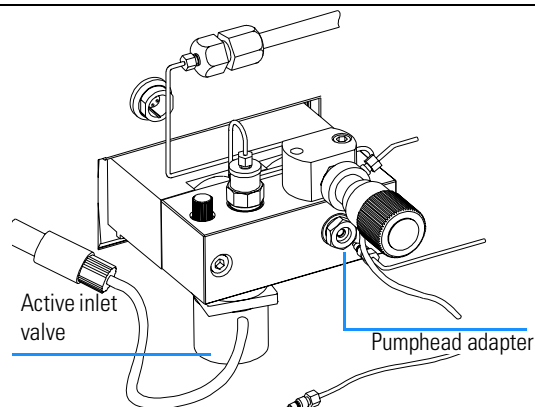

Repairing the Pump

Removing and Disassembling the Pump Head Assembly

2 Using a 3-mm hexagonal key loosen the purge valve holder and lift it up.

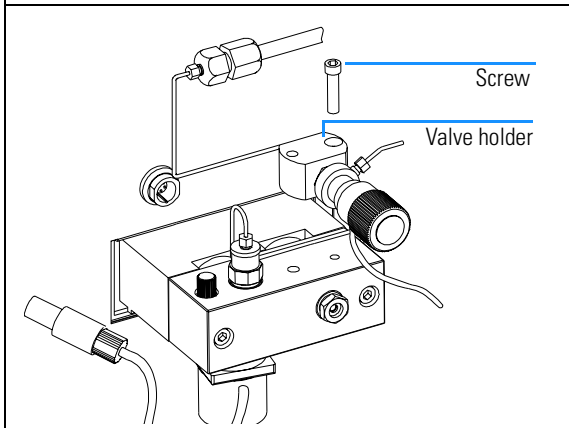

3 Using a 4-mm hexagonal key stepwise loosen and remove the two pump head screws and remove the pump head from the pump drive.

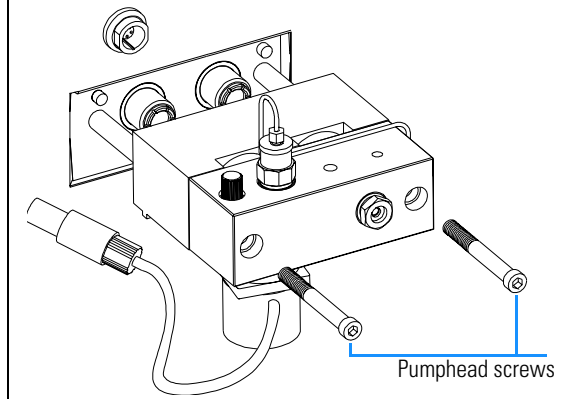

4 Place the pump head on a flat surface. Loosen the lock screw (two revolutions). While holding the lower half of the assembly, carefully pull the pump head away from the plunger housing.

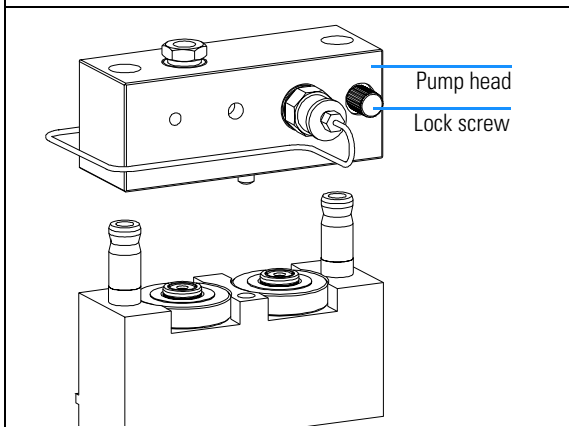

5 Remove the support rings from the plunger housing and lift the housing away from the plungers.

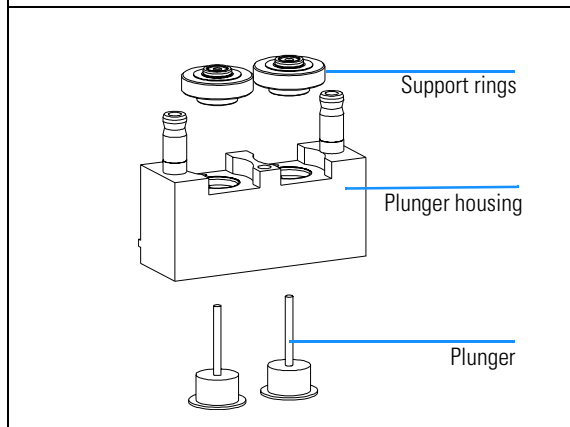

Exchanging the Pump Seals and Seal Wear-in Procedure

When required:

- Seals leaking, if indicated by the results of the leak test (Check both pump heads individually!)

Tools required:

- 3-mm hexagonal key
- 4-mm hexagonal key
- 1/4 inch wrench

Parts required:

Seals (pack of 2) 5063-6589 (standard) **or** 0905-1420 (for normal phase application)

For the seal wear-in procedure:

- Restriction capillary (5022-2159)

1 Disassemble the pump head assembly of the leaky pump head (see “Removing and Disassembling the Pump Head Assembly” on page 119).

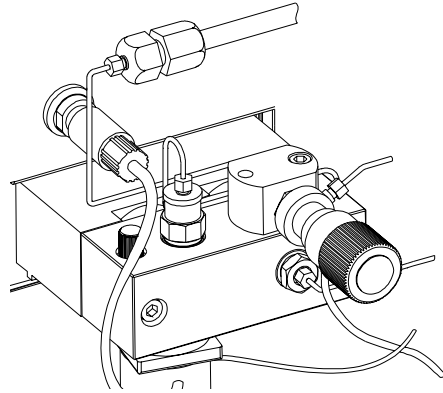

Exchanging the Pump Seals and Seal Wear-in Procedure

2 Using one of the plungers carefully remove the seal from the pump head (be careful, not to break the plunger). **Remove wear retainers, if still present.**

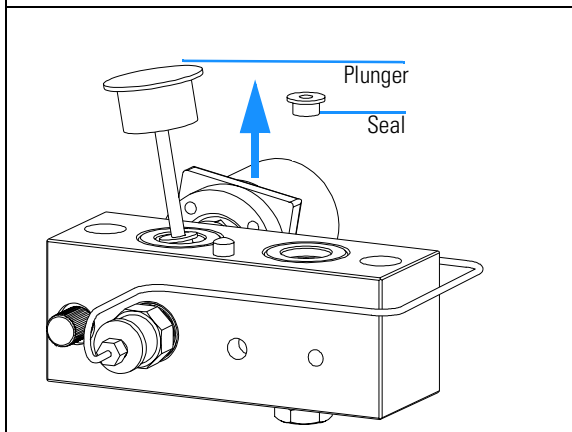

3 Clean the pump chambers with lint free cloth. Ensure all particulate matter is removed. Best cleaning results will be achieved by removing all valves (see pages 109, 112) and the capillary. Inject solvent into each chamber.

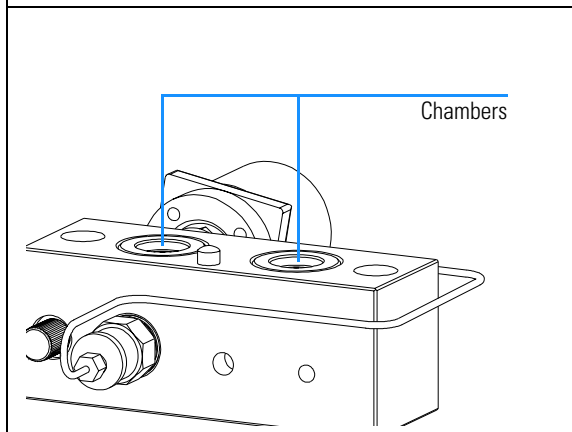

4 Insert seals into the pump head and press firmly in position.

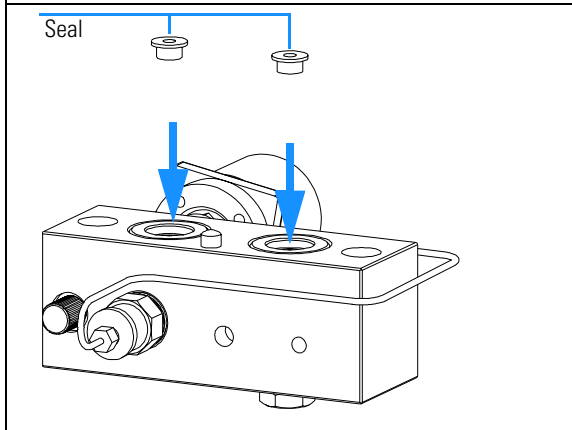

5 Reassemble the pump head assembly (see “Reassembling the Pump Head Assembly” on page 129). Reset the seal wear counter and liquimeter as described in the User Interface documentation.

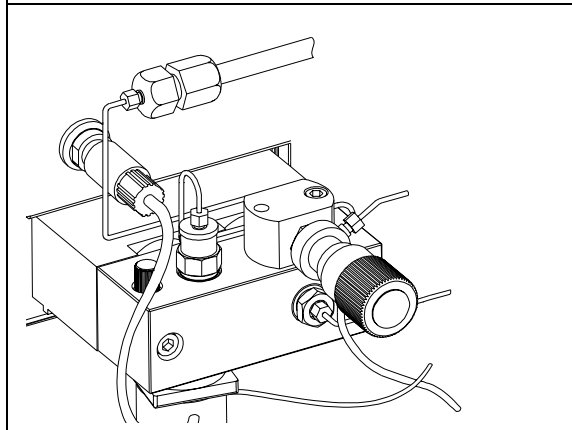

Seal Wear-in Procedure

NOTE

This procedure is required for standard seals only (5063-6589), but it will definitely damage the normal phase application seals (0905-1420).

- 1** Place a bottle with 100 ml of Isopropanol in the solvent cabinet and place the tubing (including bottle head assembly) of the pump head that is supposed to be worn-in into the bottle.
- 2** Screw the adapter (0100-1847) to the AIV and connect the inlet tube from the bottle head directly to it.
- 3** Connect the restriction capillary (5022-2159) to the purge valve. Insert its other end into a waste container.
- 4** Open the purge valve and purge the system for 5 minutes with isopropanol at a flow rate of 2 ml/min.
- 5** Close the purge valve, set the flow to a rate adequate to achieve a pressure of 350 bar. Pump 15 minutes at this pressure to wear in the seals. The pressure can be monitored at your analog output signal, with the handheld controller, Chemstation or any other controlling device connected to your pump.
- 6** Turn OFF the pump, slowly open the purge valve to release the pressure from the system, disconnect the restriction capillary and reconnect the outlet capillary at the purge valve and the connecting tube from solvent selection valve (if installed) to the AIV.
- 7** Rinse your system with the solvent used for your next application.

Exchanging the Plungers

When required:

- When scratched

Tools required:

- 3-mm hexagonal key
- 4-mm hexagonal key

Parts:

- Plunger 5063-6586

- 1** Disassemble the pump head assembly (see “Removing and Disassembling the Pump Head Assembly” on page 119).

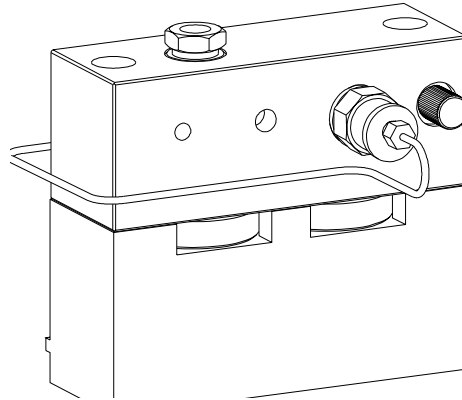

- 2** Check the plunger surface and remove any deposits or layers. Cleaning can be done with alcohol or tooth paste. Replace plunger if scratched.

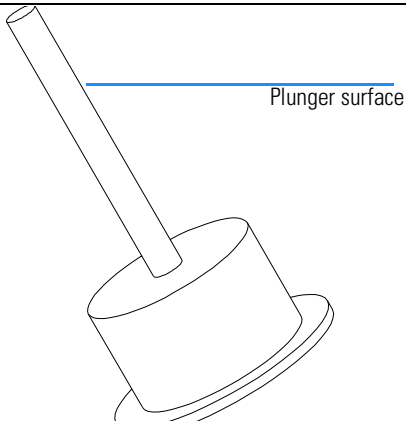

- 3** Reassemble the pump head assembly (see “Reassembling the Pump Head Assembly” on page 129).

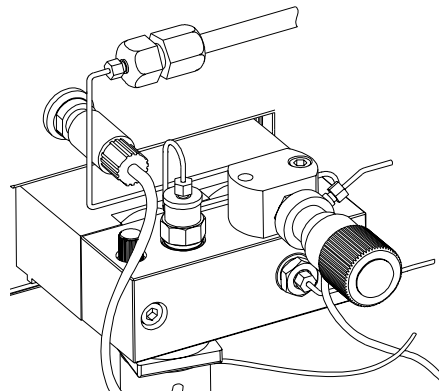

Installing the Continuous Seal Wash Option

Tools required:

❑ 4-mm hexagonal key

❑ 3-mm hexagonal key

Parts:

❑ Seal wash kit (01018-68722)

1 Disassemble the pump head assembly (see “Removing and Disassembling the Pump Head Assembly” on page 119).

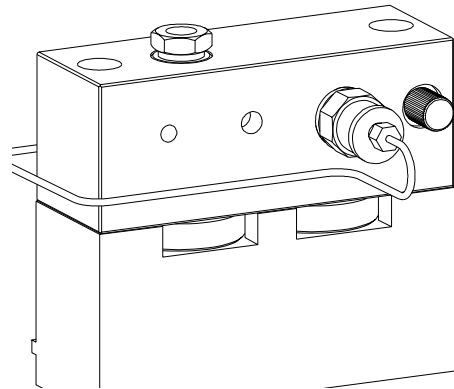

2 Remove the support rings from the plunger housing and lift the housing away from the plungers.

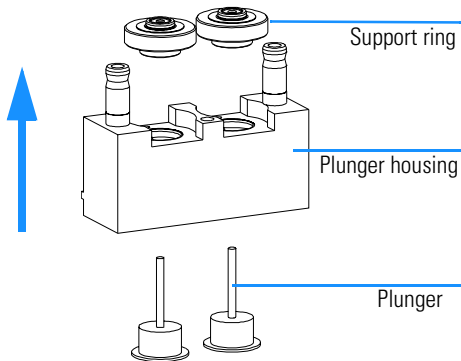

3 Check the plunger surface and remove any deposits or layers. Cleaning can be done with alcohol or tooth paste. Replace plunger if scratched.

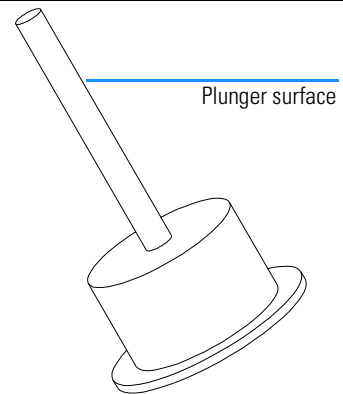

Installing the Continuous Seal Wash Option

4 Install the seal wash support ring assembly from the seal wash option kit into the plunger housing.

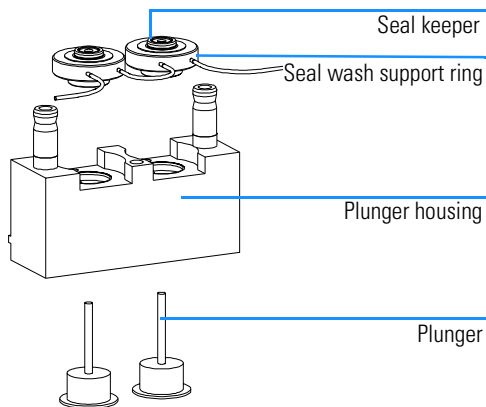

5 If necessary replace the pump seals (see page 121). Reassemble the pump head (see page 129).

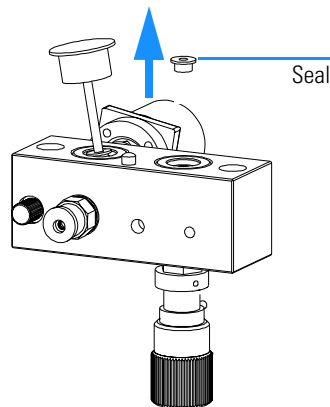

- 1** Route the wash inlet tube into a bottle filled with a mixture of distilled water and isopropanol (90/10) and place the bottle above the pump (hydrostatic pressure) in the solvent cabinet.
- 2** Route the outlet of the wash tube into a waste container.
- 3** The flow rate should be set to approximately 20 drops/minute. Use the velocity regulator attached to the wash tube to regulate the flow rate.

NOTE

The seals should never run dry. Running dry will significantly reduce the lifetime of the seals.

Exchanging the Wash Seals

When required:

- ❑ If leaking

Tools required:

- ❑ 4-mm hexagonal key
- ❑ 3-mm hexagonal key
- ❑ Insert tool
- ❑ Small flat-head screwdriver

Parts:

- ❑ Wash seal 0905-1175
- ❑ Gasket, seal wash (pack of 6) 5062-2484

- 1** Disassemble the pump head assembly (see “Removing and Disassembling the Pump Head Assembly” on page 119).

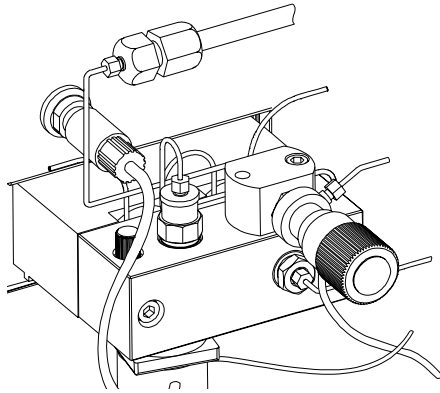

- 2** Remove the seal keeper and the seal wash support rings from the plunger housing. Remove the seal keeper from the support ring assembly.

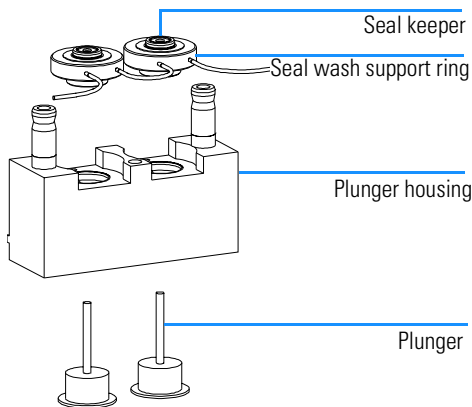

- 3** Using the blade of a flat head screwdriver remove seal wash gasket and the secondary seal from the support ring.

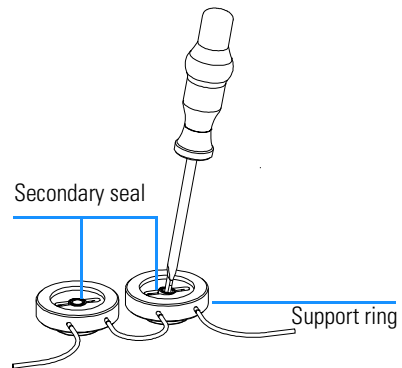

Repairing the Pump
Exchanging the Wash Seals

4 Using the insert tool press the seal (spring pointing upwards) into the recess of the support ring. Place a seal wash gasket in the recess of the support ring and replace the seal keeper.

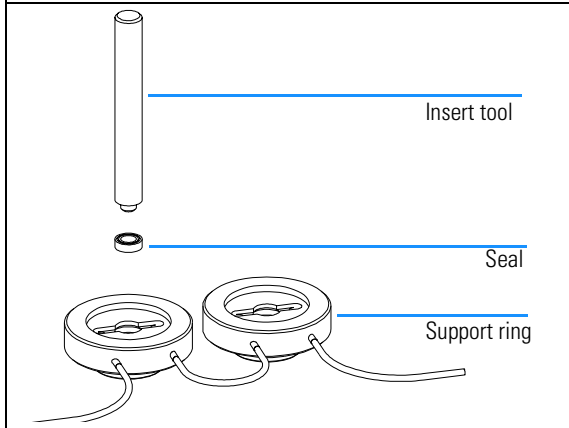

5 Reassemble the pump head assembly (see “Reassembling the Pump Head Assembly” on page 129).

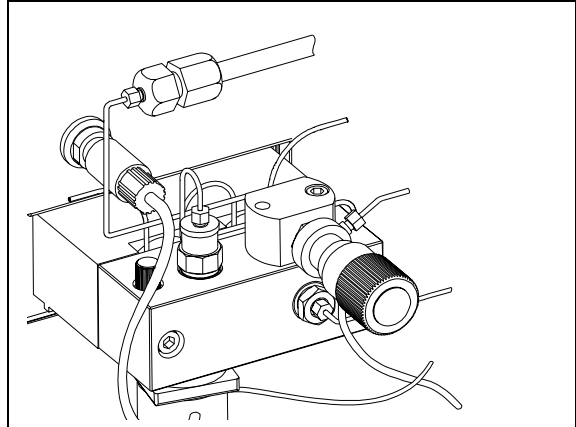

Reassembling the Pump Head Assembly

Tools required:

- ❑ 3-mm hexagonal key
- ❑ 4-mm hexagonal key
- ❑ PTFE lubricant (79841-65501)

1 Place the support rings on the plunger housing (plungers not installed) and snap the pump head and plunger housing together.

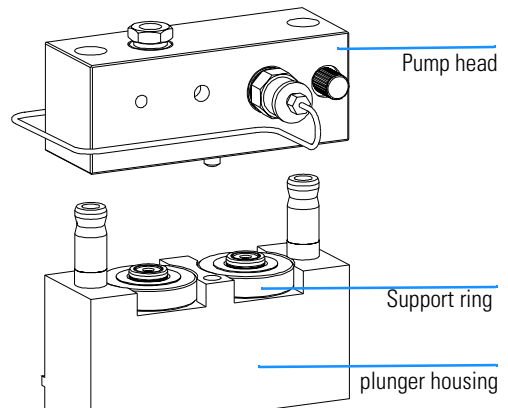

2 Tighten the lock screw.

Lock screw

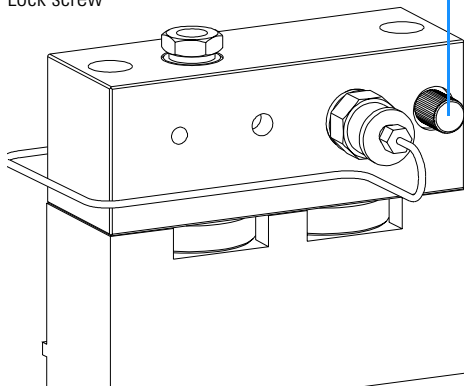

3 Carefully insert the plungers into the pump head assembly and press them completely into the seals.

Plunger

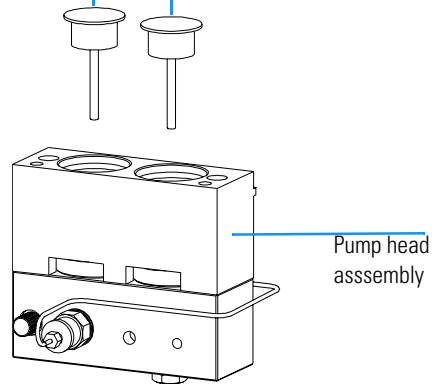

Repairing the Pump

Reassembling the Pump Head Assembly

4 Slide the pump head assembly onto the pump drive. Apply a small amount of pump head grease to the pumphead screws and the balls of the spindle drive. Tighten screws stepwise with increasing torque. Fix the purge valve holder to the pump head.

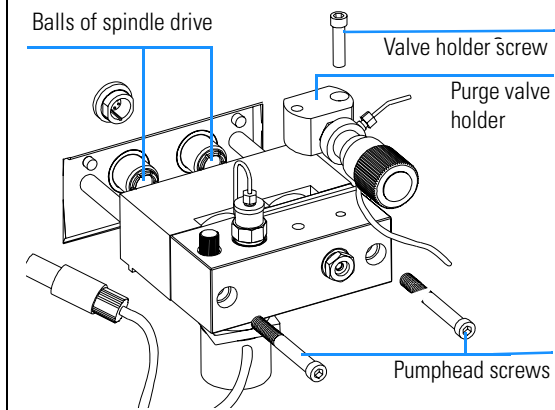

5 Reconnect the capillaries, tubing and the active inlet valve cable to the connector.

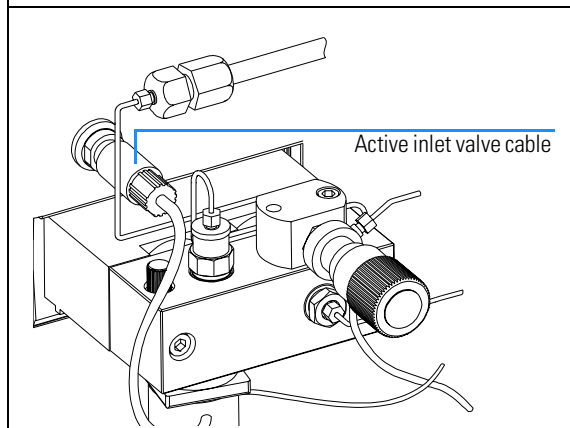

Exchanging the Optional Interface Board

CAUTION

The interface board is sensitive to electrostatic discharge. Always use the ESD kit when handling electronic boards.

When required

Board defective

Part required

BCD (Interface) board, see "Optional Interface Boards" on page 223

- 1 Switch off the binary pump at the main power switch. Unplug the pump from main power.
- 2 Disconnect cables from the interface board connectors.
- 3 Loosen the screws. Slide out the interface board from the binary pump.
- 4 Install the new interface board. Secure screws.
- 5 Reconnect the cables to the board connector.

Figure 22

Exchanging the Interface Board

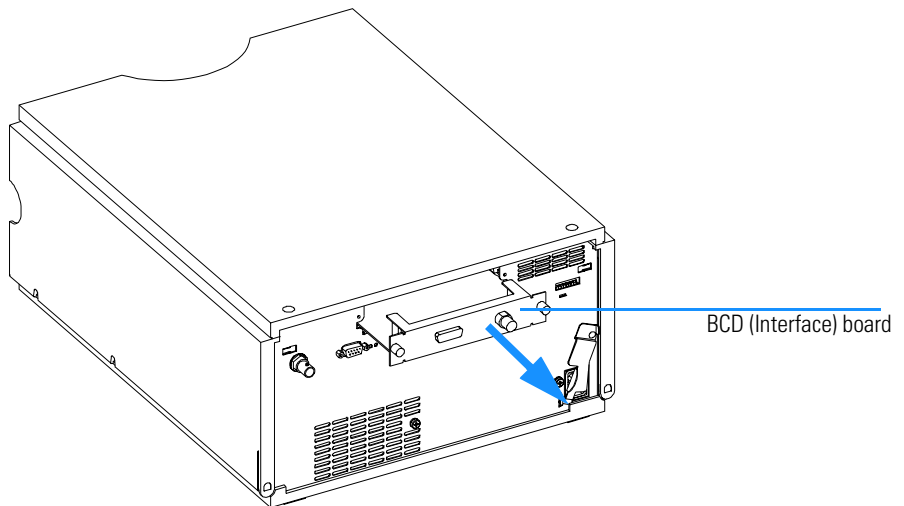

Exchanging Internal Parts

WARNING The following procedures require opening the main cover of the binary pump. Always ensure the binary pump is disconnected from the line power when the main cover is removed. The security lever at the power input socket prevents that the pump cover is taken off when line power is still connected.

WARNING To disconnect the binary pump from line, unplug the power cord. The power supply still uses some power, even if the switch on the front panel is turned off.

WARNING When opening capillary or tube fittings solvents may leak out. Please observe appropriate safety procedures (for example, goggles, safety gloves and protective clothing) as described in the material handling and safety data sheet supplied by the solvent vendor, especially when toxic or hazardous solvents are used.

NOTE The electronics of the binary pump will not allow operation of the binary pump when the top cover and the top foam are removed. A safety light switch on the main board will inhibit the operation of the binary pump. Always operate the binary pump with the top foam and top covers in place.

CAUTION Internal components may be sensitive to electrostatic discharge (ESD). Always use an ESD kit when handling internal parts.

The procedures in this section describe how to exchange internal parts. You must remove the binary pump from the stack in order to open the main cover.

Removing the Top Cover and Foam

Tools required

Screwdriver Pozidriv #1

Preparations for this procedure

Switch off binary pump at the main power switch.
Disconnect the solvent inlet tubes from the solvent selection valve or the adapter at the active inlet valve.
Beware of leaking solvents due to hydrostatic flow.
Remove leak funnel with the waste tube.
Remove the solvent cabinet from the binary pump.

1 Remove the front cover by pressing the clip fastener on both sides of the cover.

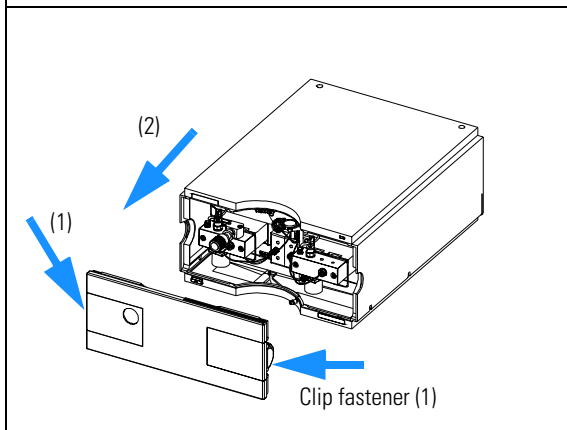

2 Unplug the power cord and move the lever towards the power socket.

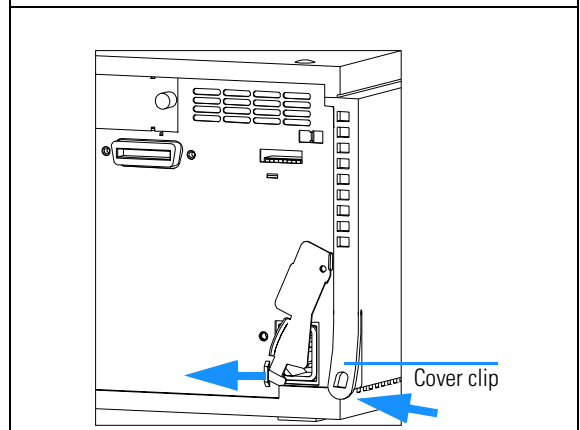

Repairing the Pump

Removing the Top Cover and Foam

3 Lift the clips on both sides of the top cover (1). Remove the top cover (2).

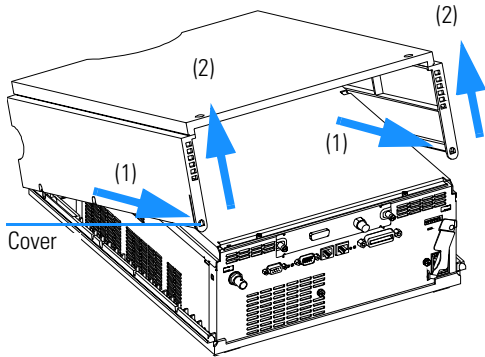

4 Unscrew the screws on the top plate and remove the plate by lifting its back first and then sliding to the front.

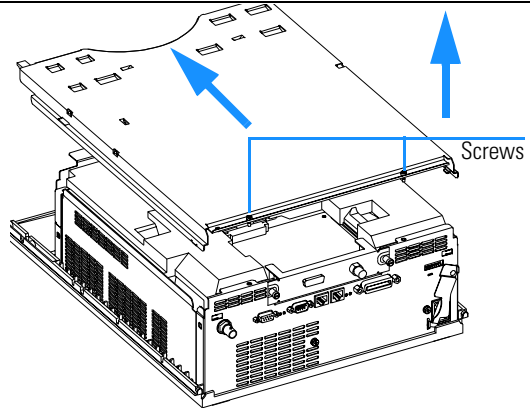

5 If an optional interface board is installed, remove it from the binary pump.

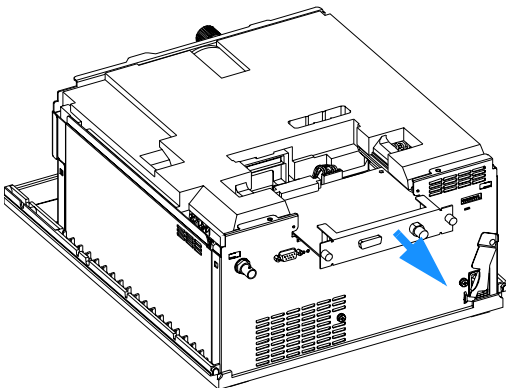

6 Remove the top foam.

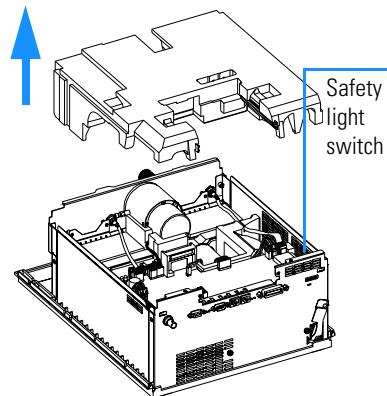

Repairing the Pump

Removing the Top Cover and Foam

Do not connect a power plug to the binary pump module after removing the top covers.

A safety light switch on the main board will prevent operation when the covers are removed.

The next figure shows the position of the light switch on the board.

7 Position of the safety switch on the main board.

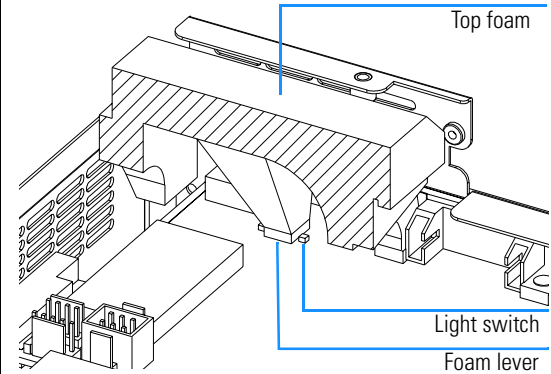

Exchanging the High Pressure Pump Main Board (HPM Board)

When required	Board defective
Tools required	Wrench 14 mm Wrench 7 mm Wrench 5 mm
Parts required	HPM board, G1312-66520, exchange part number G1312-69520

- 1 Turn off the pump, disconnect all cables and remove the pump from the stack.
- 2 Remove the top covers and foam, see “Removing the Top Cover and Foam” on page 133.
- 3 Disconnect all connectors from the main board.

Connector	Description	Connector	Description
J1	RS232	J17	Encoder A
J2	Remote	J19	AIV - A
J3	Analog pressure signal	J23	Leak sensor
J4	GPIB	J24	Damper
J5/6	CAN connector	J25	Fan
J9	Power supply	J26	Interface board
J12	Motor B	J27	Encoder B
J16	Motor A	J28	AIV - B
		J30	Solvent selection valves

NOTE

When removing connectors, counterhold on connector J3 with one hand.

Figure 23 Board Layout of the HPM Board

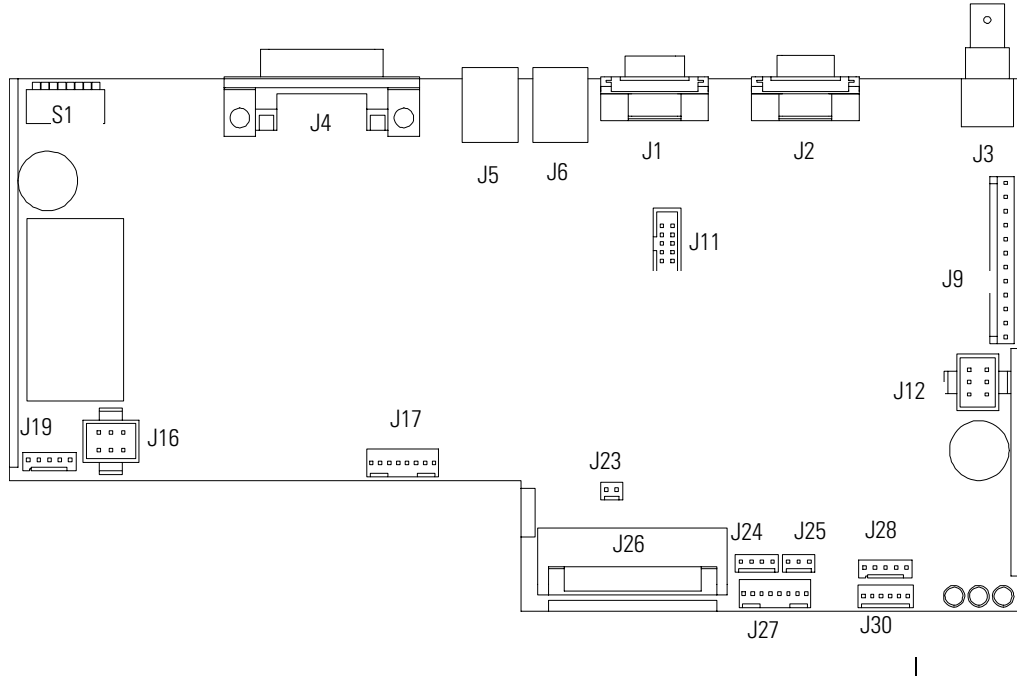

- 4 Remove the connector screws from the GPIB, Remote and from the analog pressure output connector.
- 5 Remove the board. Place it on an ESD kit.

WARNING

The RFI spring plate sitting on the board connectors is very sharp! Be careful, not to cut yourself, when removing it from the old board and sliding it onto the new board.

- 6 In most cases the RFI spring plate (Radio Frequency Interference spring plat, prevents radio emissions from the instrument to ambient) remains on the interface connectors of the board. Carefully remove the spring plate from the old board and slide onto the new board before installing the new board in the pump (the RFI spring plate is NOT part of an exchange board).
- 7 If you have to exchange other parts, also, continue with that work first.

Exchanging the High Pressure Pump Main Board (HPM Board)

- 8 On the new board check the switch setting of address switch S1, see “Default Addresses for Agilent 1100 Series Modules” on page 231.

NOTE

An incorrect switch setting (e.g., TEST/BOOT) may cause the pump to turn into a basic mode (yellow or red flashing status light). In such a case turn off the pump, re-set the address switches, and turn on the pump again.

- 9 Install the new board and reconnect the connectors. Make sure that the board is fitted correctly in the board recess holes at the rear panel.

NOTE

Please make sure that J27 is not accidentally connected into the position of J24 /J25 (possible on revision A and B boards). This will damage the encoder of pump drive B when turned on.

- 10 Replace the connector screws.

Figure 24

Rear of Binary Pump

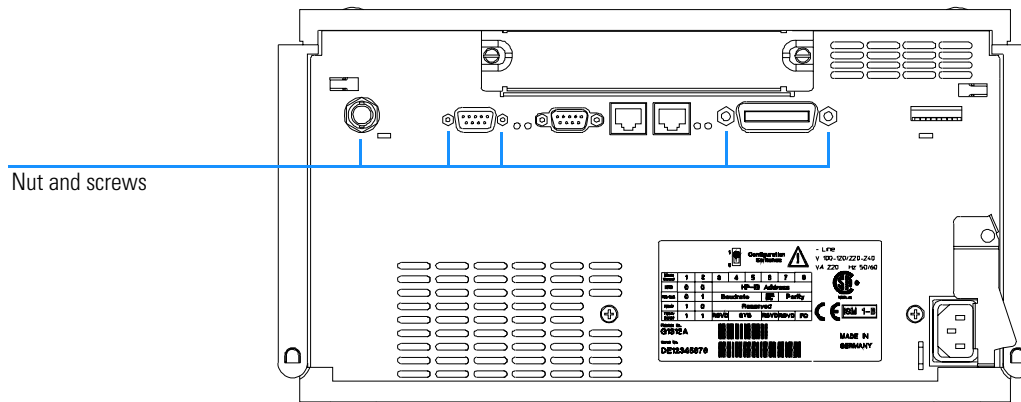

- 11 Replace foam and top covers, see “Replacing the Top Cover and Foam” on page 160.
- 12 Reinstall the pump in the stack. Reconnect all cables. Turn on the binary pump. If the status indicator turns red, continue with the section “Entering the Type Command” on page 139, other wise continue with the section “Entering the Serial Number” on page 140.

Entering the Type Command

NOTE

After the installation of a new mainboard the *TYPE* (binary) of the module is normally automatically detected. The specific *TYPE* tells the pump how to configure itself during turn on. In some cases, especially when a defective mainboard is replaced with an older version of mainboard, the automatic *TYPE* detection does not work. When the *TYPE* of the exchange main board does not match the pump, a pump configuration error will occur during pump turn on. This will cause the pump status indicator to be red. In this case the *TYPE* of the module has to be entered using the procedure described in the following sections.

You must change the *TYPE* of the replacement main board to agree with the binary pump (G1312A). The *TYPE* can be entered using either the control module or the ChemStation, see “Entering the Type Command using the Control Module” on page 139 or “Entering the Type Command using the ChemStation” on page 140.

Entering the Type Command using the Control Module

- 1 Connect the control module to the pump.
- 2 From *Views* (press F5) select the *System* screen, then press *Tests* (F3).
- 3 Using the up/down arrows, make sure that the binary pump is highlighted and press *Enter*. The Tests screen for the binary pump should now be displayed.
- 4 While in the *Tests* screen, press m.m (m dot m). From the box now displayed, select the *Command* line, and press *Enter*.
- 5 Into the box labeled *Instr*, enter the command TYPE G1312A.
- 6 Letters and numbers are created using the up and down arrows. There must be a blank space between the word TYPE and the letter G.

NOTE

It is important to enter the TYPE command correctly. An incorrect type command may cause the module to turn on in it's resident mode. In such a case, re-enter the TYPE command correctly.

- 7 When the command is entered, press *Enter* to highlight the complete command.
- 8 Press the *Execute* (F8) key. Below the box, a reply line should then say: Reply RA 0000 TYPE "G1312A" .

Exchanging the High Pressure Pump Main Board (HPM Board)

- 9 Turn off the module, then turn it on again. Turn on should be normal. In the *Records* screen, the product# column should indicate the binary pump. If a ChemStation is also connected, re-boot it now.

Entering the Type Command using the ChemStation

The TYPE is entered by typing a specific command into the command line at the bottom of the main user interface screen.

- 1 To enter the TYPE for a specific module, type the following command into the command line:

```
print sendmodule$(lpmp, "TYPE G1312A")
```

NOTE

It is important to enter the TYPE command correctly. An incorrect type command may cause the module to turn on in it's resident mode. In such a case, re-enter the TYPE command correctly.

- 2 The reply line will respond with RA 0000 Type "G1312A".
- 3 Turn the binary pump off, then on again. Then, re-boot the ChemStation. Boot up and subsequent control of the system should be normal.
- 4 The TYPE of a module can also be identified by typing the following command into the command line:

```
print sendmodule$ (lpmp, "TYPE?")
```

The reply line will give the module TYPE.

Entering the Serial Number

Entering the Serial Number using the Control Module

- 1 Connect the control module to the binary pump. Turn on the pump.
- 2 In the control module, press *Views (F5)* and select the *system* screen, then press *Records (F4)*. Using the up/down arrows, make sure that the binary pump is highlighted.
- 3 Press *FW Update (F5)*. Now, press the *m* key. This will display a box which says *Update Enter Serial#*.
- 4 Press *Enter*. This will display the box labeled *Serial#*.

- 5 Letters and numbers are created using the up and down arrows. Into the box labeled *Serial#*, enter the 10-character serial number for the binary pump. When the 10-character serial number is entered, press *Enter* to highlight the complete serial number. Then, press *Done* (*F6*).

NOTE

For firmware revisions below A02.00 it is very important never to press *Done* if the *Serial#* box is blank. In this case, the module can no longer be recognized by either the control module or the ChemStation. The main board must then be replaced.

- 6 Turn the binary pump off, then on again. The *Records* screen should display the correct serial number.
- 7 If a ChemStation is also connected, re-boot the ChemStation now as well.

Entering the Serial Number using the ChemStation

Module serial numbers are entered by typing specific commands into the command line at the bottom of the main user interface screen.

- 1 To enter a module serial number, type the following command into the command line:

```
print sendmodule$(lpmp, "ser YYYYYYYYYY")
```

Where: YYYYYYYYYY is the 10-character serial number of the binary pump

NOTE

The first two characters are letters, which should be capitalized.

The reply line will respond with RA 0000 SER followed by the module serial number you just entered.

- 2 Turn off the binary pump, then on again. Then, re-boot the ChemStation. If the serial number you have just entered is different than the original module serial number, you will be given the opportunity to edit the configure 1100 access screen during the re-boot of the ChemStation.
- 3 After boot-up, the serial number you have just entered can be seen under the *Instrument menu* of the main user interface screen. The serial number of the binary pump can also be seen by typing the following command into the command line:

```
print sendmodule$ (lpmp, "ser?")
```

The reply line will give the serial number of the binary pump.

Replacing the Binary Pump's Firmware

The installation of new firmware is required

- if a new version solves problems of the currently installed version.
- if the version of firmware on the new main board (HPM) after an exchange of the board is older than the one previously installed.

To upgrade the binary pump's firmware follow the procedures and instructions given on the internet @:

<http://www.agilent.com/chem>

To download and install always the newest available version of firmware on your system or call your local service provider for assistance.

Exchanging the Damper

When required: No pressure output or when leaking

Tools required: Screwdriver Pozidriv #1
Wrench 1/4 inch

Parts required: Damper, PN 79835-60005

NOTE Do not totally remove the Z-panel when the damper is in its place. The heavy damper may fall down..

1 Remove the front cover, top cover and top foam section (see “Removing the Top Cover and Foam” on page 133).

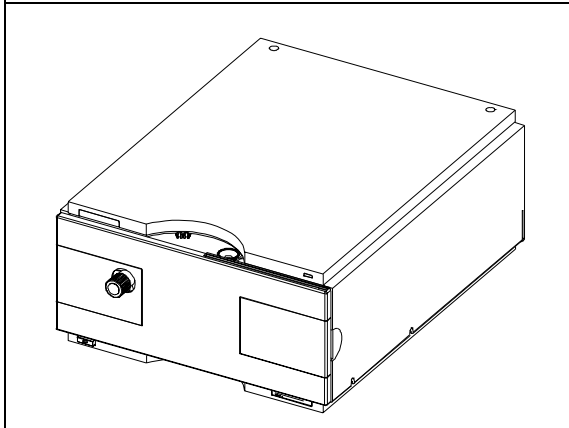

2 Disconnect both active inlet valve cables and disconnect the two damper capillaries. Disconnect the damper connector (J24) at the main board. Unclip the mixing chamber from its holder.

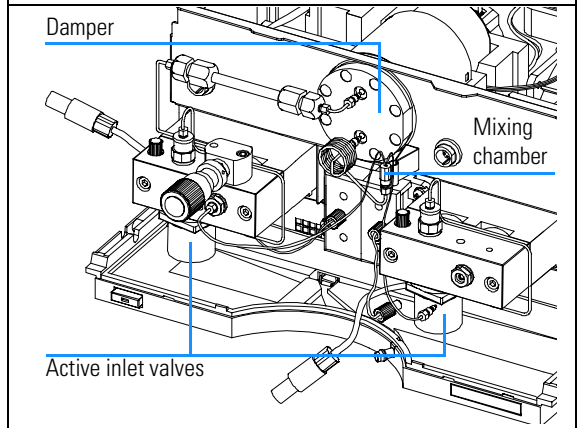

Repairing the Pump
Exchanging the Damper

3 Loosen the screws of the Z-panel, fold it forward and remove the damper.

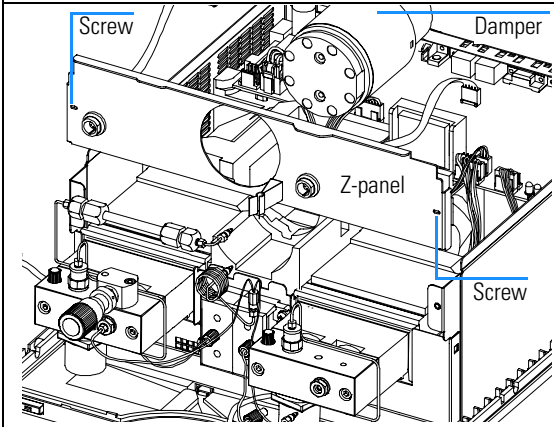

4 Replace the Z-panel and the new damper and fix it with the two screws. Reconnect the damper connector (J24) at the main board.

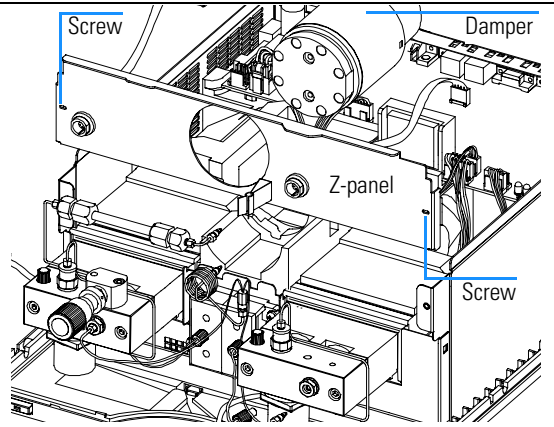

5 Reconnect the damper capillaries. Plug the mixing chamber back into its holder. Reconnect the two AIV cables to the Z-panel.

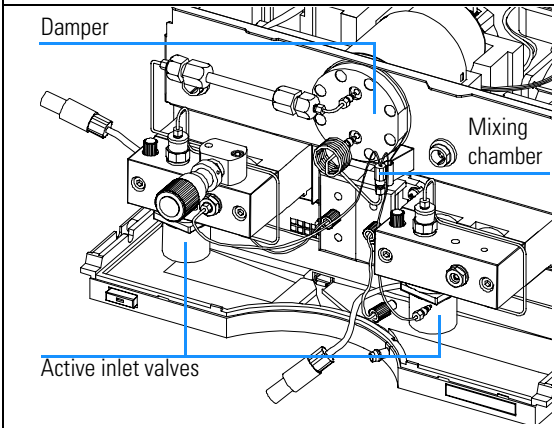

6 Replace the top foam section, optional interface board, front cover, and top cover (see “Replacing the Top Cover and Foam” on page 160).

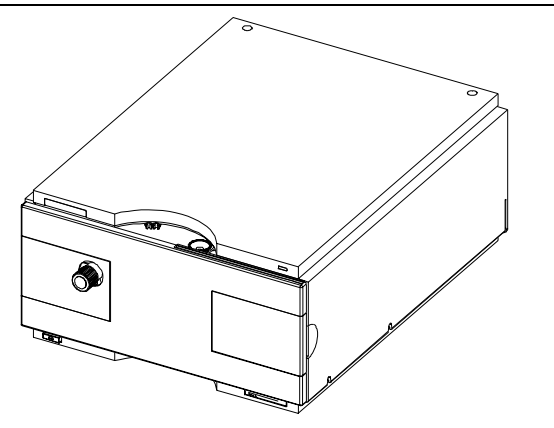

Exchanging the Fan

When required:	Fan not running
Tools required:	Screwdriver Pozidriv #1 Wrench 1/4 inch
Parts required:	Fan, PN 3160-1017

1 Remove the front cover, top cover and top foam section (see “Removing the Top Cover and Foam” on page 133).

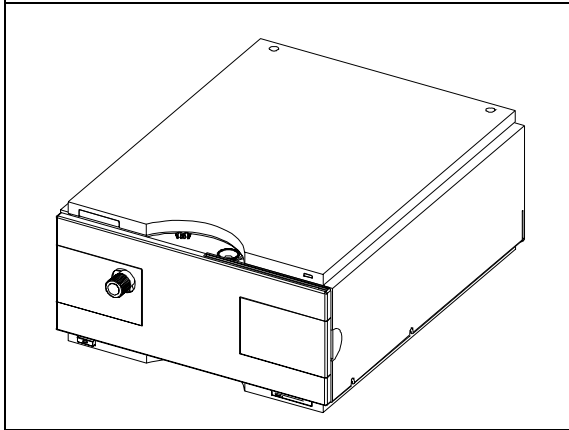

2 Disconnect the capillaries from pump head B. Disconnect both active inlet valve cables and disconnect the two damper capillaries. Disconnect the damper connector (J24) at the main board. Unclip the mixing chamber from its holder.

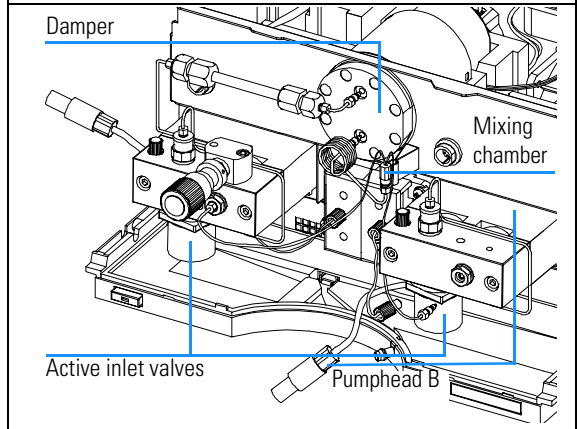

Repairing the Pump Exchanging the Fan

3 Loosen the screws of the Z-panel, fold it forward and remove the damper. Disconnect the two flat cables of the active inlet valve connector at the main board (J19, J28) and remove the Z-panel.

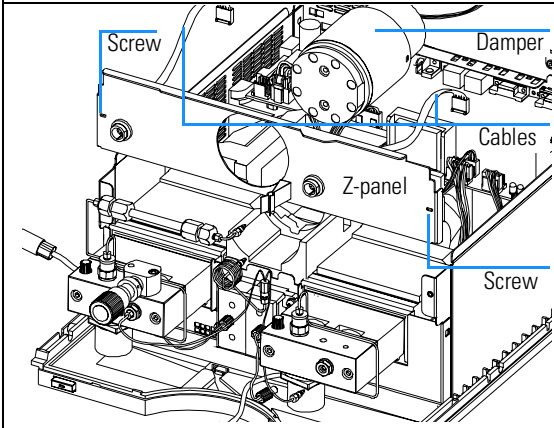

4 Disconnect the cables of pump B (J12, J27) from the main board and lift out the complete assembly.

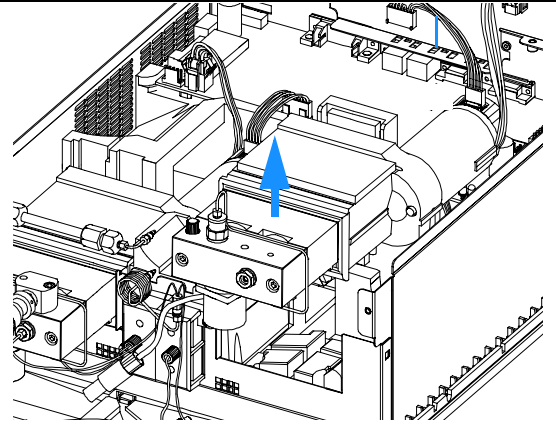

5 Disconnect the fan cable (J25) at the main board and slide the fan towards the front and move it out of the unit.

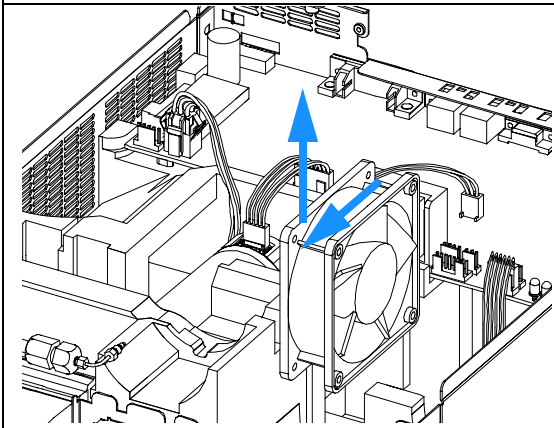

6 Place the new fan into the recess and connect to the main board (J25). Make sure that the air flow is directed as indicated (arrow on the fan points in the same direction as on the foam).

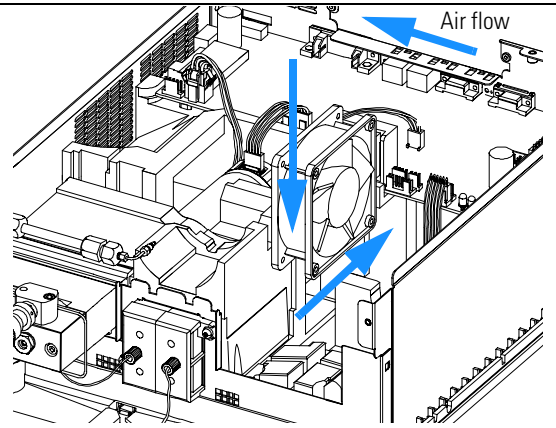

Repairing the Pump
Exchanging the Fan

7 Place pump B back into its recess and connect to the main board.

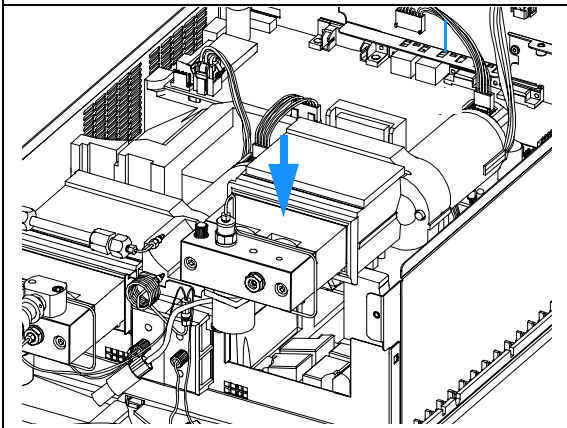

8 Replace the Z-panel and the damper and fix it with the two screws. Reconnect the damper connector (J24) and the AIV cables at the main board (J19, J28).

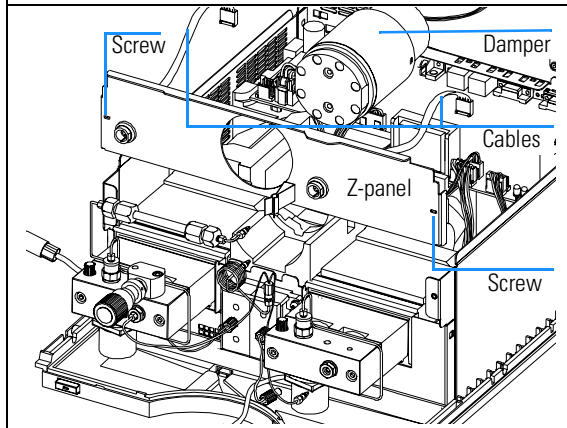

9 Reconnect all capillaries at pump head B and the two connectors for the active inlet valves. Fix the mixing chamber in the clip at the Z-panel.

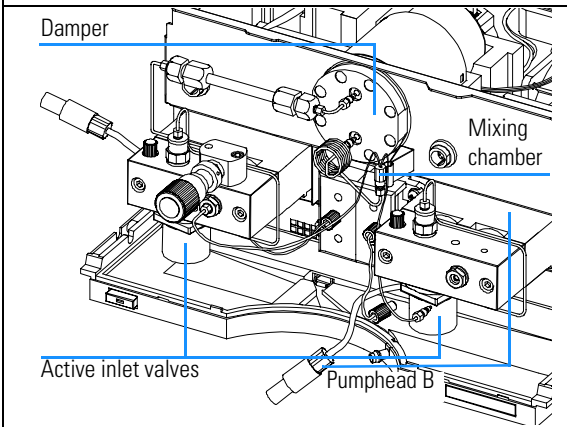

10 Replace the top foam section, optional interface board, front cover, and top cover (see “Replacing the Top Cover and Foam” on page 160).

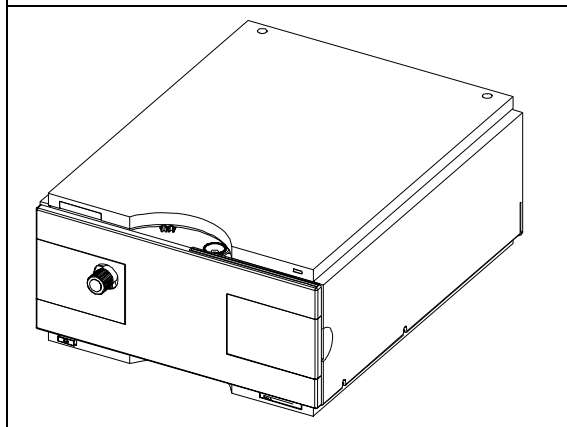

Exchanging a Pump Drive

WARNING

Never start the pump when the pump head is removed. This may damage the pump drive.

The binary pump has two pump-drive assemblies. The A drive is located on the left side and the B drive on the right side. The difference in the replacement procedures of both is the purge valve assembly located on the A drive and the location of the pump-drive connectors on the HPM board. This procedure describes the exchange of the pump drive of the A side.

When required:

- Error message: Motor Drive Power

Tools required:

- Screwdriver Pozidriv #1
- Wrench 1/4 inch
- 4-mm hexagonal key

Part required:

- Pump drive G1311-60001,
exchange part number G1311-69001

1 Switch off the pump at the main power switch, remove all cables and tubings, remove the pump from the stack. Remove the front cover, top cover and top foam section (see “Removing the Top Cover and Foam” on page 133).

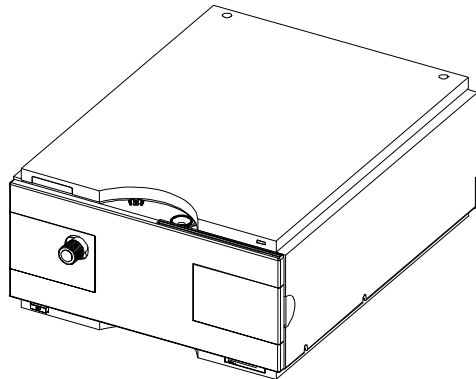

Repairing the Pump
Exchanging a Pump Drive

2 Disconnect all capillaries and the waste tubing from the pump head and damper and disconnect the active inlet valve connectors of both pumps. Unclip the mixing chamber from its holder.

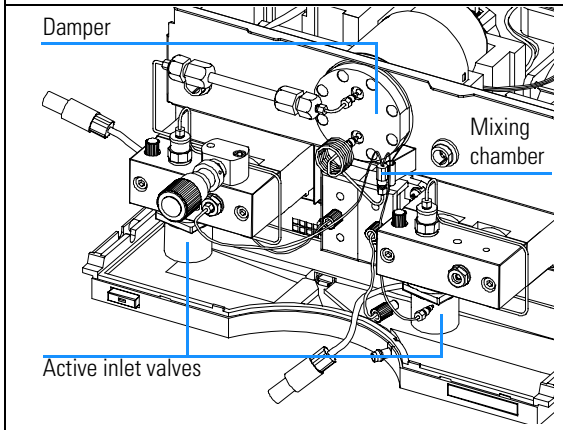

3 Using a 4-mm hexagonal key, stepwise loosen and remove the two pump head screws and remove the pump head from the pump drive.

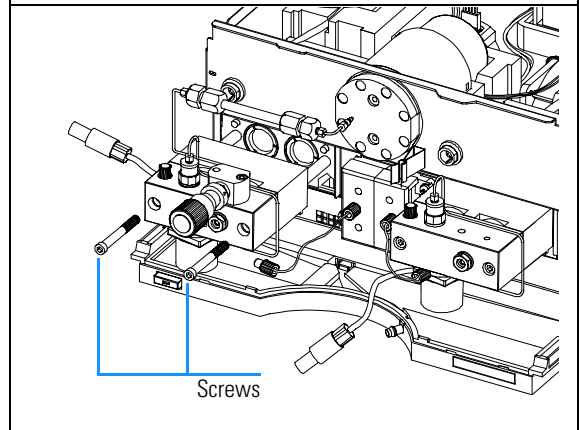

4 Loosen the two screws from the Z-panel, fold it forward, disconnect the damper at the main board (J24) and remove it. Disconnect the two active inlet valve connector cables from the main board (J19, J28) and put the Z-panel aside.

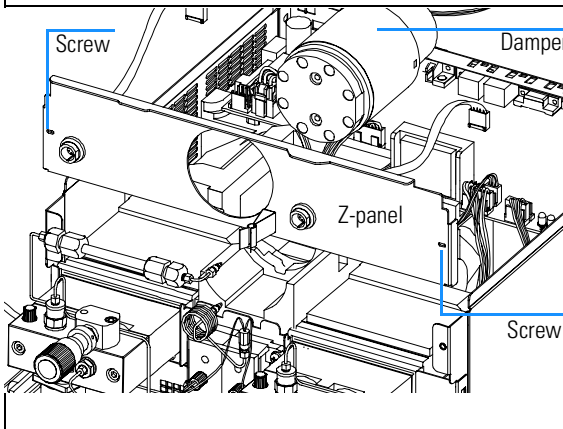

5 Disconnect the pump drive cables (J16, J17 **or** J12, J27) from the main board and lift the pump drive out of the foam.

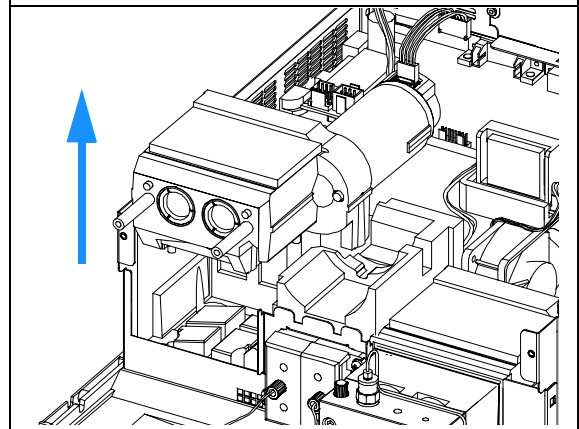

Repairing the Pump
Exchanging a Pump Drive

6 Place the new pump drive into the recess in the foam part and connect the cables to the connectors on the main board (J16, J17 **or** J12, J28).

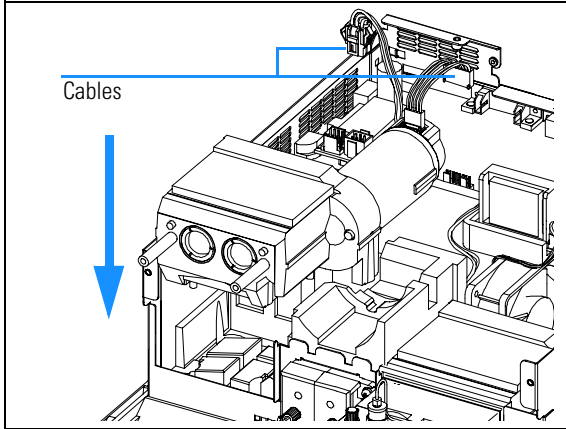

7 Replace the damper and the Z-panel and secure it with the two screws. Reconnect the cables to the main board (J19, J28).

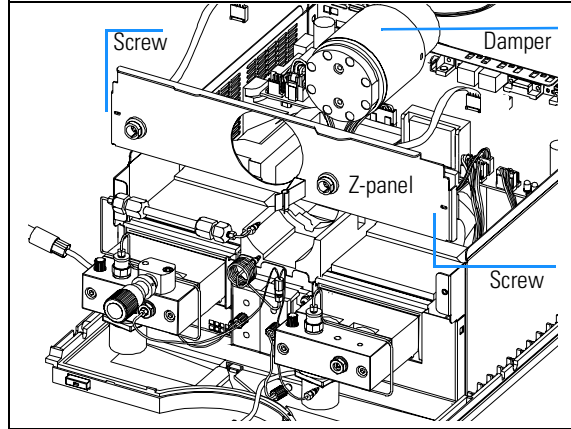

8 Reinstall the pump heads and secure with the two screws.

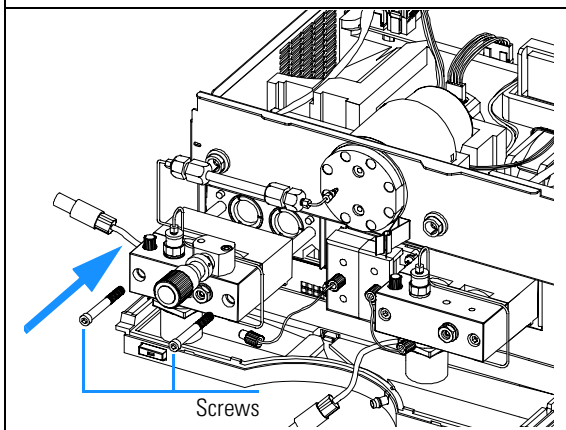

9 Reconnect all capillaries and cables. Secure the mixing chamber in its holder.

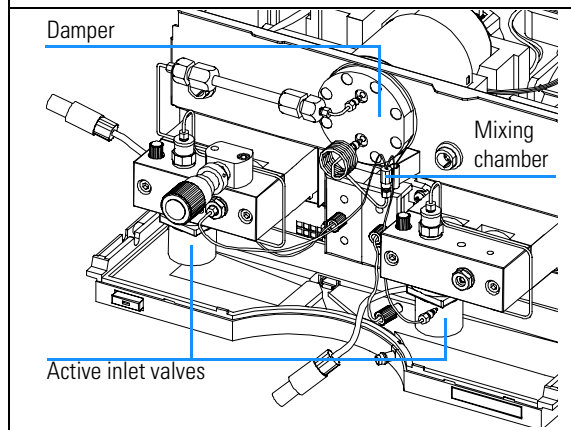

Exchanging the Power Supply

When required:

- If defective

Tools required:

- Screwdriver Pozidriv #1
- Wrench 1/4 inch
- Wrench 14 mm
- Wrench 7 mm
- Wrench 5 mm

Part required:

- Power supply 0950-2528

1 Disconnect all cables and capillaries, remove the pump from stack, remove the front cover, top cover and top foam section (see “Removing the Top Cover and Foam” on page 133).

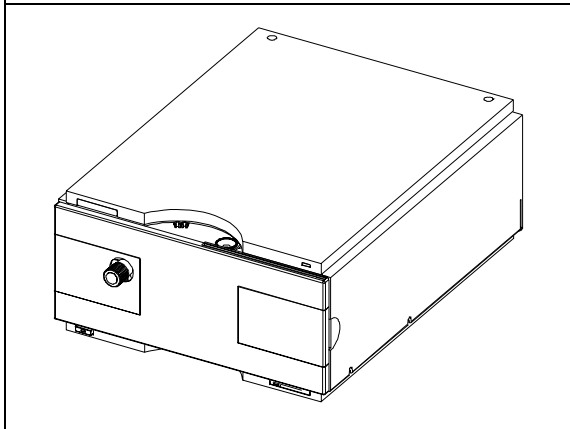

2 Disconnect all capillaries, tubes and connectors from the two pump heads and the damper. Remove the mixing chamber from its holder.

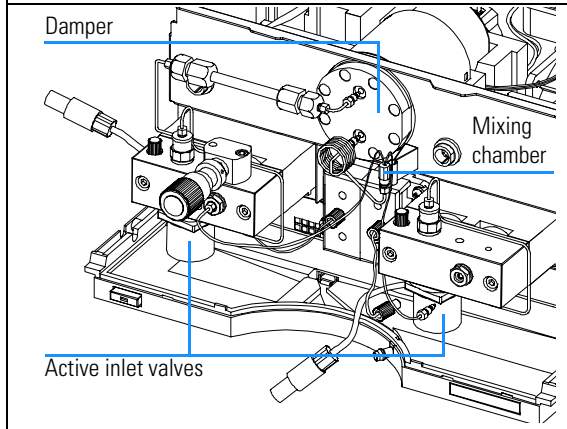

Repairing the Pump
Exchanging the Power Supply

3 Disconnect the connectors of the active inlet valve and the damper from the main board (J19, J24, J28), loosen the Z-panel screws and take out the damper. Remove the Z-panel.

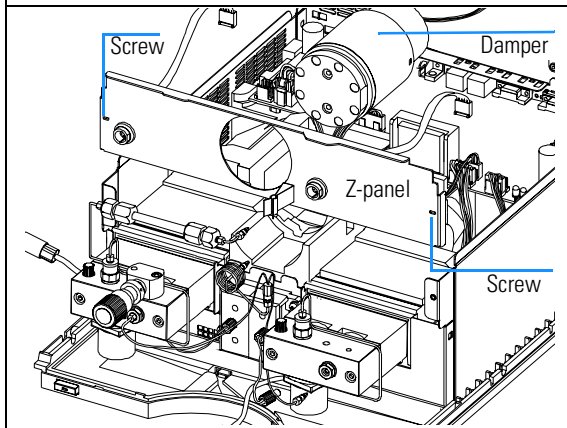

4 Disconnect both pumps from the main board (J16, J17, J12, J28) and lift them out of the foam.

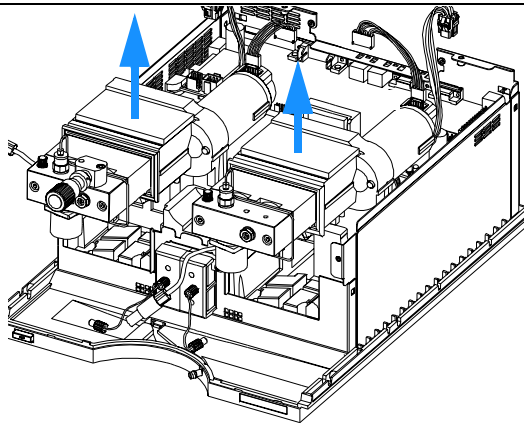

5 Remove the solvent selection valve assembly and its connectors, see “Exchanging the Solvent Selection Valve” on page 117, if installed).

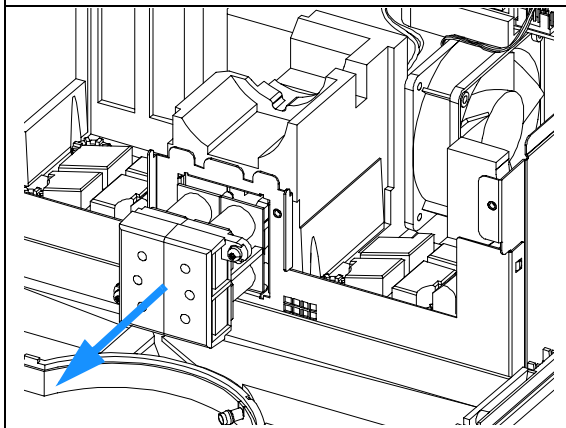

6 Remove the HPM board after having disconnected the remaining connectors, see “Exchanging the High Pressure Pump Main Board (HPM Board)” on page 136.

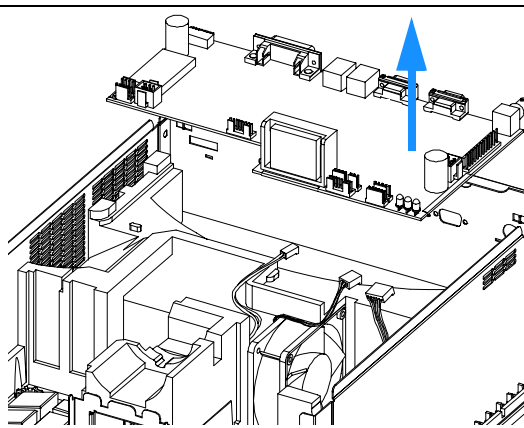

Repairing the Pump
Exchanging the Power Supply

7 Push the leak sensor cable through the recess of the solvent selection valve and lift out the bottom foam.

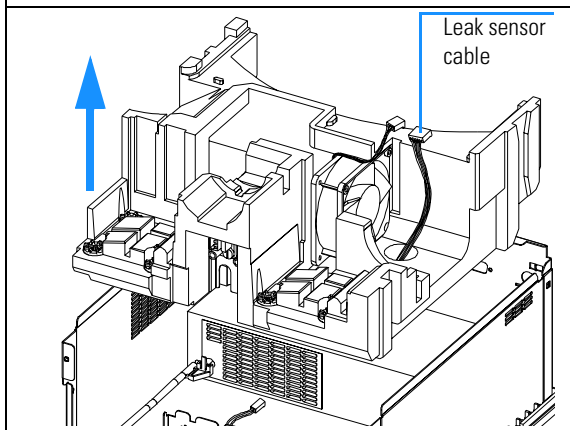

8 Loosen and remove the power-supply screws at the rear panel.

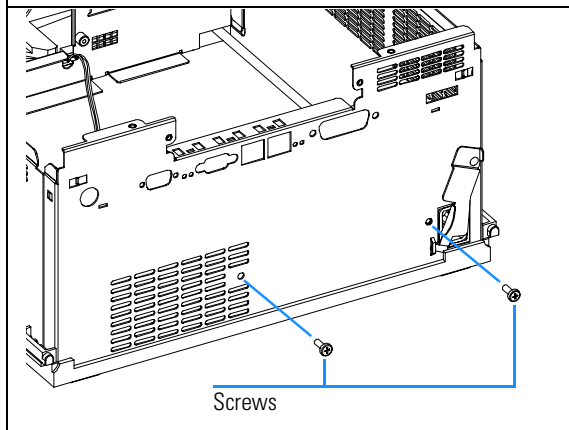

9 Unclip the power supply light pipe from the power supply and pull out the coupler.

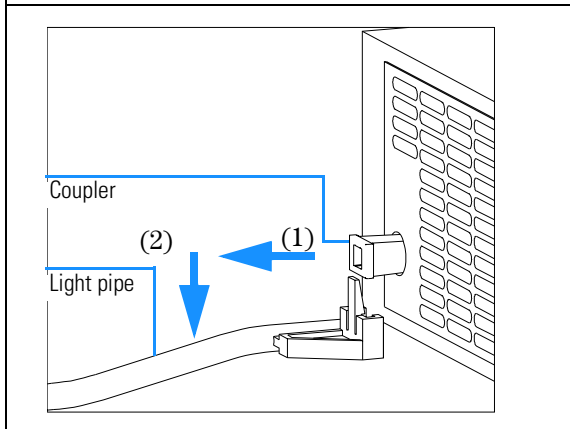

10 Lift the power supply out of the unit.

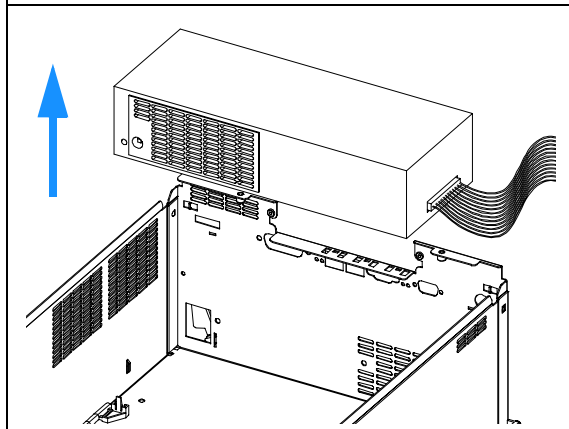

Repairing the Pump
Exchanging the Power Supply

11 Place the new power supply into the instrument and fix it with the two screws at the rear panel.

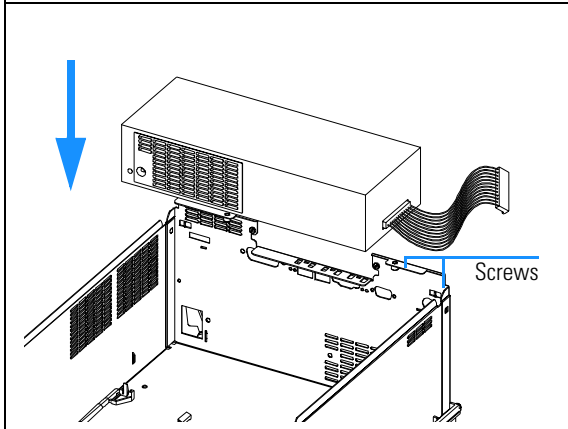

12 Place the coupler onto the switch in the power supply and clip the light pipe back onto the coupler.

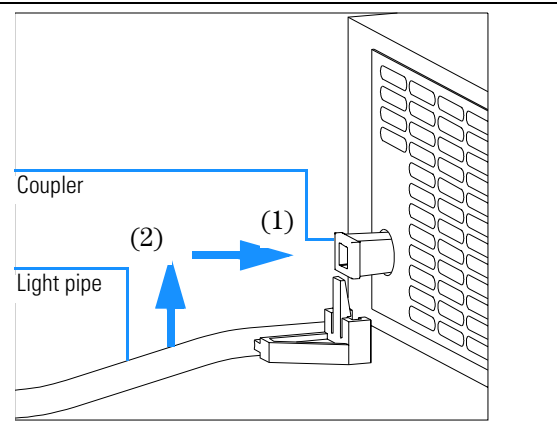

13 Slide the leak sensor cable through the bottom foam. Replace the bottom foam and fix the leak sensor cable in the foam. Make sure the leak sensor cable is not damaged by the sheet metal.

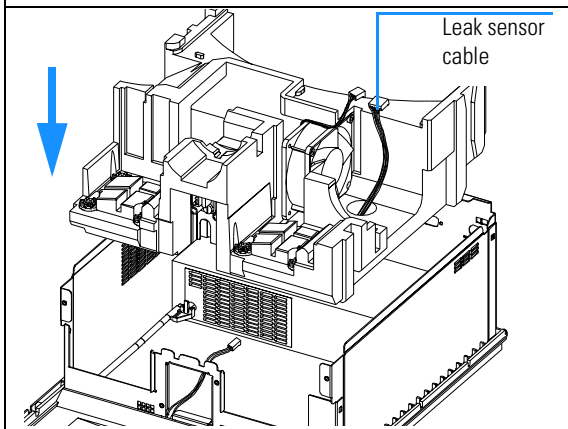

14 Reinstall the main board and reconnect all cables, see “Exchanging the High Pressure Pump Main Board (HPM Board)” on page 136.

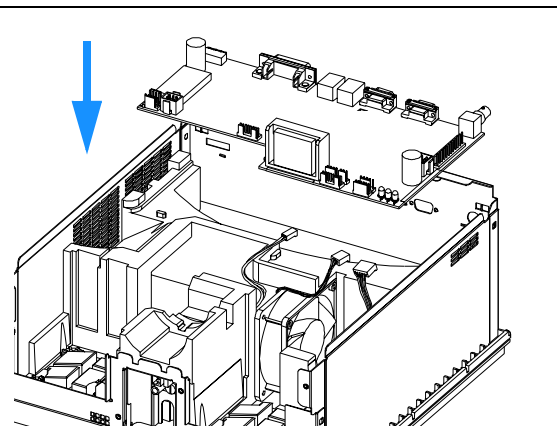

Repairing the Pump
Exchanging the Power Supply

15 Re-install solvent selection valve, if present (see “Exchanging the Solvent Selection Valve” on page 117).

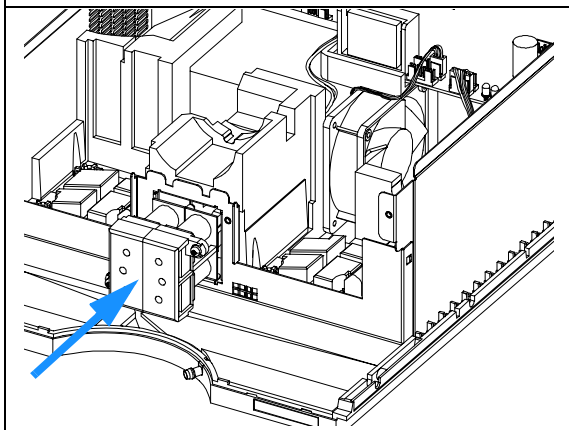

16 Replace the two pump units and connect to the main board (J16, J17, J12, J27).

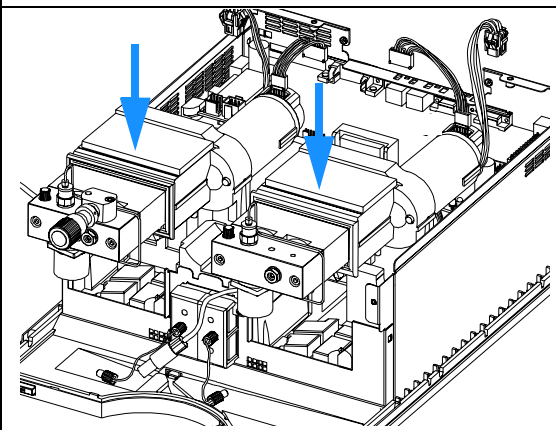

17 Place Z-panel into its position and replace the damper. Fix the Z-panel and reconnect the cables at the main board (J19, J28, J24).

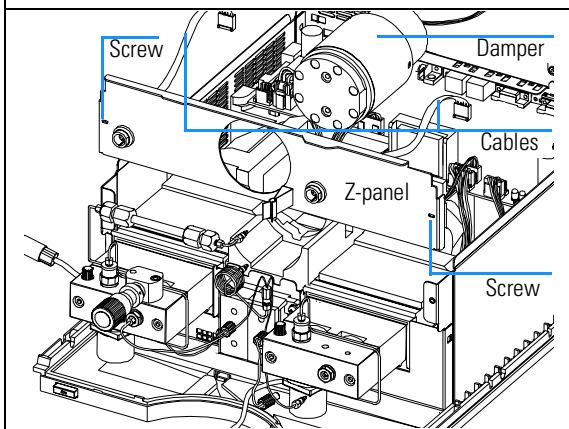

18 Reconnect all capillaries, tubes and cables to the pump heads and the damper. Fix the mixing chamber in its holder.

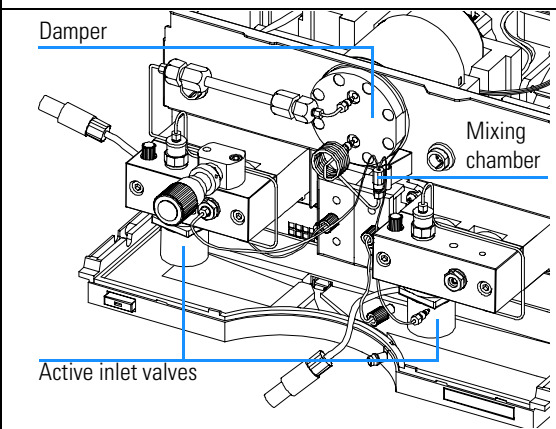

Exchanging the Leak Sensor

When required Leak messages without leak in the funnel

Tools required Screwdriver Pozidriv #1
Wrench 1/4 inch
Wrench 14 mm
Wrench 7 mm
Wrench 5 mm

Parts required Leak sensor, 5061-3356

- 1 Remove the top covers and foam, see “Removing the Top Cover and Foam” on page 133.
- 2 Remove the main board, see “Exchanging the High Pressure Pump Main Board (HPM Board)” on page 136.
- 3 Remove pump units, damper and bottom foam, see “Exchanging the Power Supply” on page 151 (step 1 through step 7).
- 4 Unclip the leak pan and place it in front of the binary pump.
- 5 Pull the leak sensor out of the leak pan and lift the cable out of the metal plate.
- 6 Place the new leak sensor into the leak pan, see Figure 25 and replace the pan. Make sure that the cable is located in the recess of the bottom metal plate.
- 7 Reinstall the bottom foam. Make sure that the leak sensor cable is guided through the foam to the top side.
- 8 Replace the main board, see “Exchanging the High Pressure Pump Main Board (HPM Board)” on page 136.
- 9 Replace the two pump assemblies, the damper and the Z-panel.
- 10 Replace top foam and top cover, “Replacing the Top Cover and Foam” on page 160.

Repairing the Pump
Exchanging the Leak Sensor

Figure 25 **Exchanging the Leak Sensor**

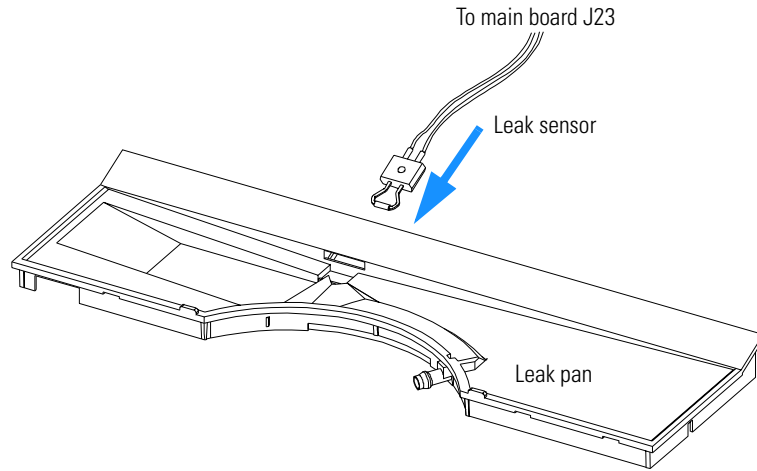

Exchanging Status Light Pipe

When required:	If part is broken
Tools required:	Screwdriver Pozidriv #1
Part required:	Status light pipe 5041-8384

Preparation for this procedure:

- Remove the front cover and top cover, see “Removing the Top Cover and Foam” on page 133.

1 The status light pipe is clipped into the top cover.

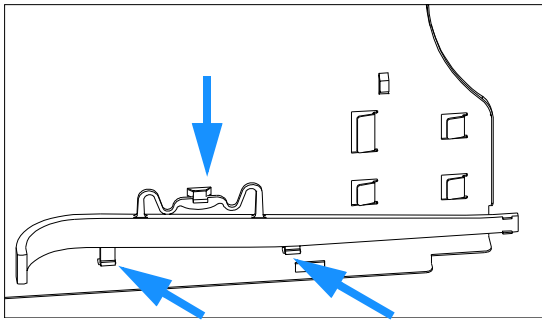

- 2** Replace the top cover, see “Replacing the Top Cover and Foam” on page 160.
- 3** Replace the binary pump into the stack and reconnect the cables and capillaries.
- 4** Turn on the binary pump.

Assembling the Main Cover

When required	If cover is broken
Tools required	None
Parts required	Cover kit G1312-68703 (includes base, top, left and right)

NOTE The cover kit contains all parts, but it is not assembled.

WARNING In case you insert the left or right side in the opposite position, you may not be able to remove the side from the top part.

1 Place the top part on the bench and insert the left and right side into the top part.

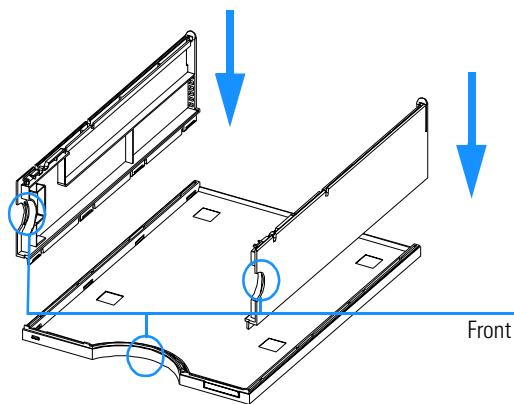

2 Replace the cover.

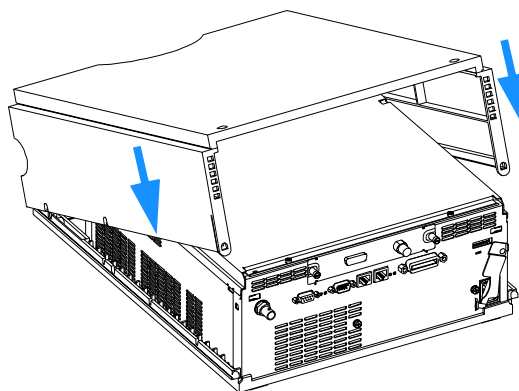

3 Replace the binary pump into the stack and reconnect the cables and capillaries.

4 Turn on the binary pump.

Replacing the Top Cover and Foam

Tools required Screwdriver Pozidriv #1

Preparations for this procedure Make sure that after your repair all assemblies, cables, capillaries and connectors are located in its correct place.

1 Place the damper cable in a curve to the right side towards the active inlet valve cable of pump B. Replace the top foam section.

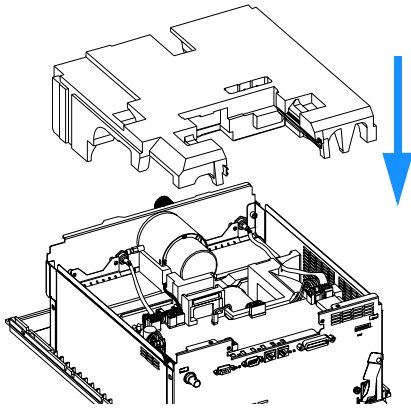

2 Make sure that the foam is installed correctly and is located in the safety light switch.

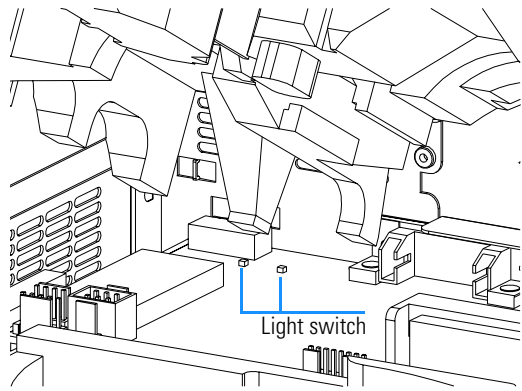

Repairing the Pump
Replacing the Top Cover and Foam

3 Location of foam in the light switch.

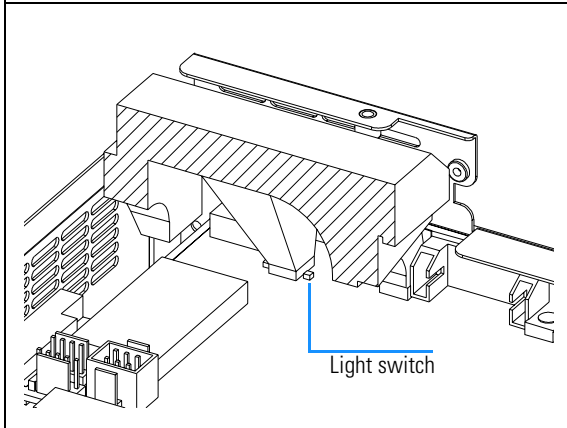

4 Replace the optional interface board or the board cover plate.

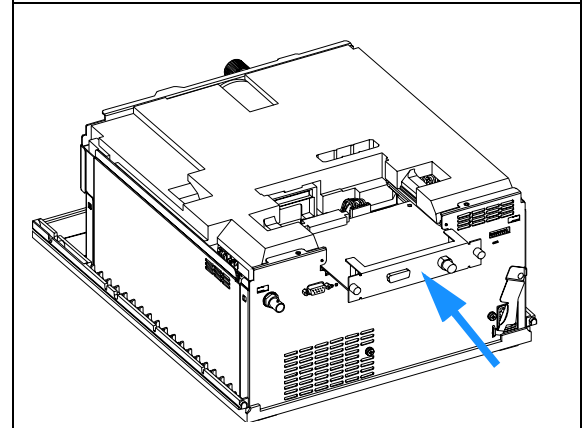

5 Replace the metal cover (slide the metal tabs into place (1) underneath the Z-Panel in the front, then lower the back of the metal plate (2)) and fix the two holding screws.

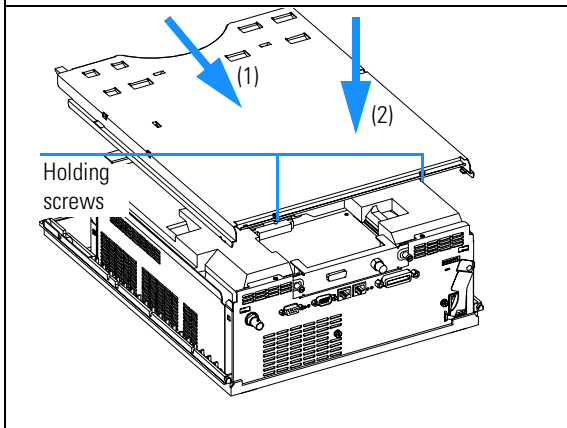

6 Replace the top cover.

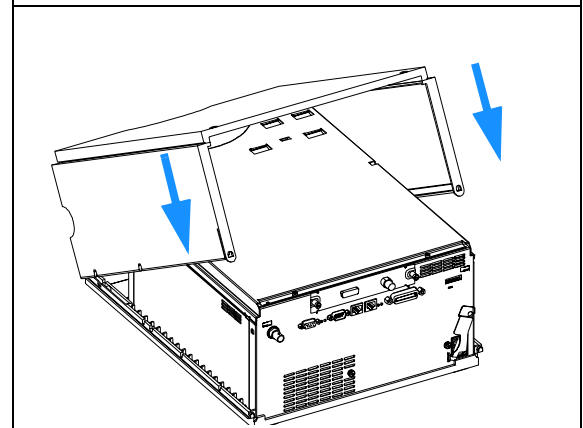

Repairing the Pump
Replacing the Top Cover and Foam

7 Ensure clips are seated correctly, move lever back.

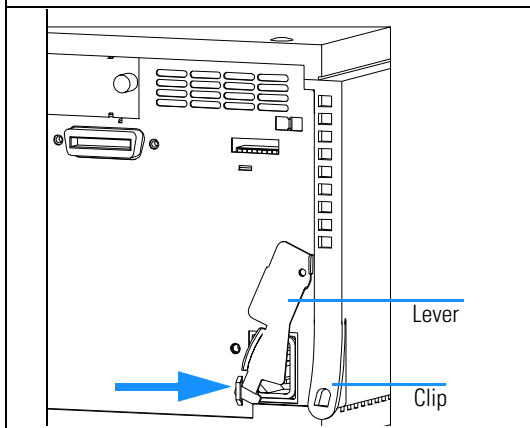

8 Replace the leak funnel with the waste tube. Locate the lower end of the waste tube in the holder of the leak pan.

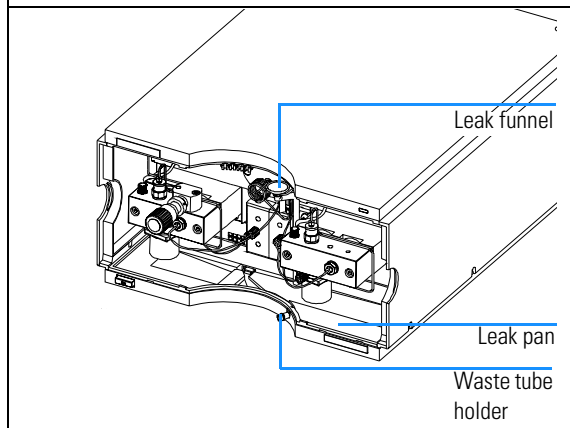

9 Place the binary pump back to its position in the stack, replace solvent cabinet and reconnect all tubes and capillaries (figure shows configuration with solvent selection valve).

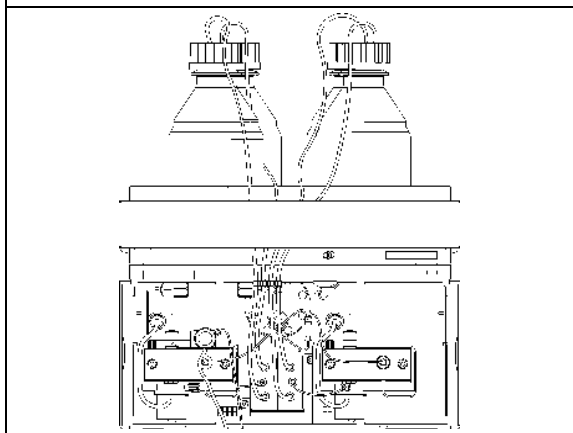

10 Replace the front covers and reconnect the power cable to the binary pump. Switch on the binary pump .

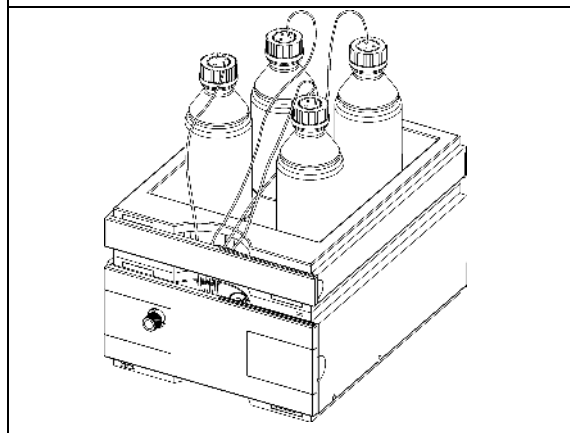

Parts and Materials

Detailed illustrations and lists for identification
of parts and materials

Parts and Materials

Figure 26 Overview of Main Assemblies (Front View)

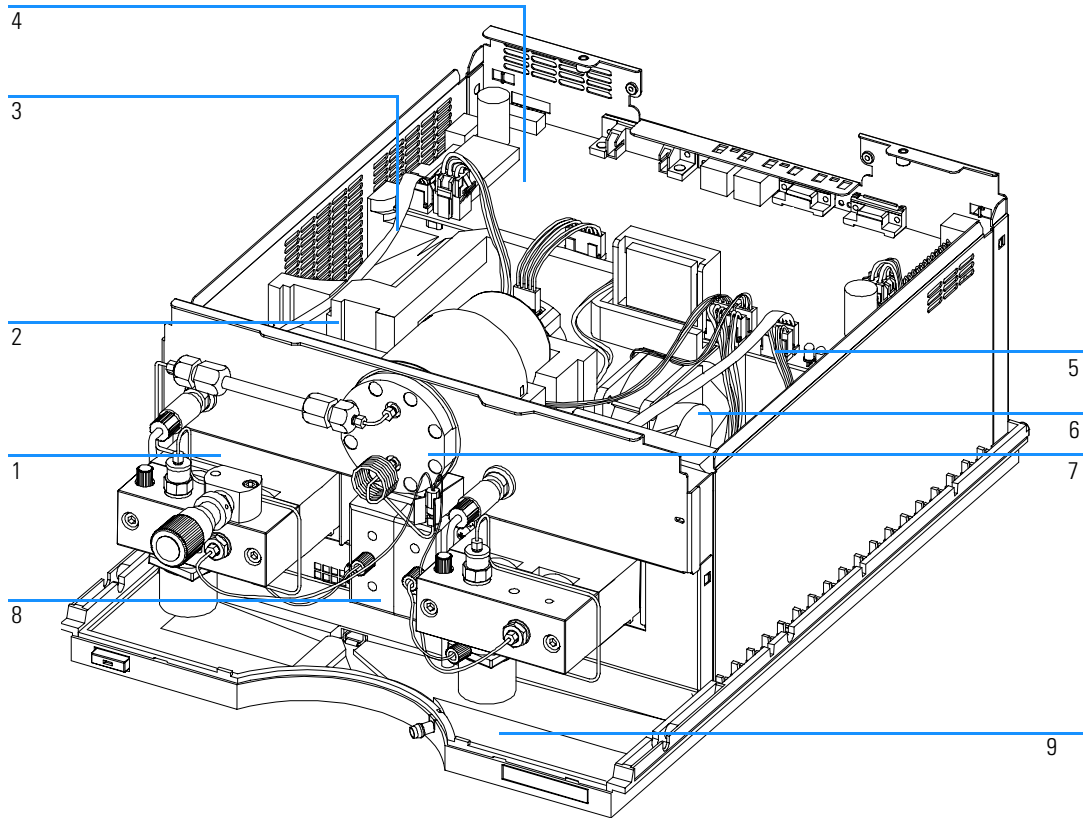

Table 7**Repair Parts — Pump Housing and Main Assemblies (Front View)**

Item	Description	Part Number
1	Pump head, see page 179	G1311-60004
2	Pump drive assembly	G1311-60001
	Exchange assembly — pump drive	G1311-69001
3	Cable assembly — AIV to main board	G1311-61601
4	High-pressure pump main board (HPM)	G1312-66520
	Exchange assembly — HPM board	G1312-69520
5	Cable assembly — solvent selection valve	G1312-61602
6	Fan assembly	3160-1017
7	Damping unit	79835-60005
8	Solvent selection valve (half of a complete valve)	G1312-60000
	Screw, solvent selection valve	5022-2112
9	Leak pan - pump	5041-8390

Figure 27 Overview of Main Assemblies (Rear View)

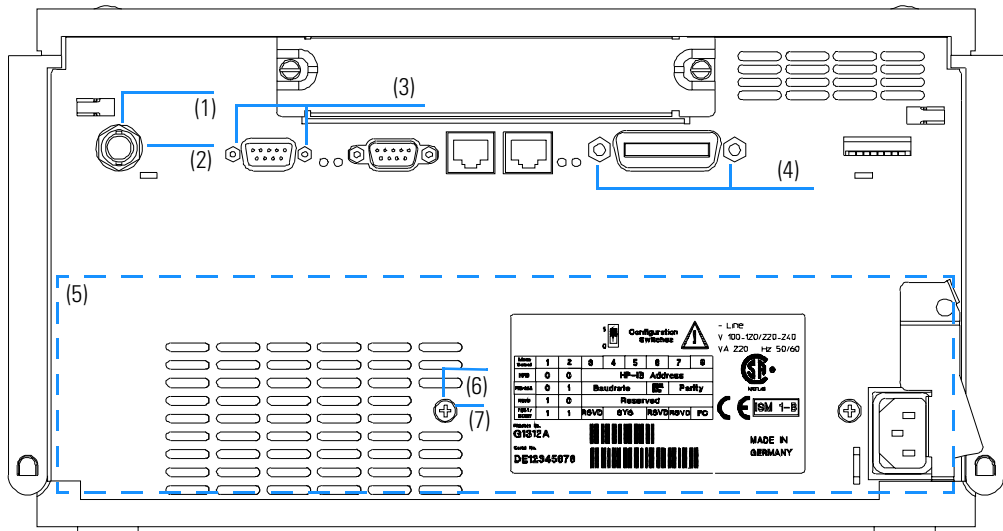

Table 8

Repair Parts — Pump Housing and Main Assemblies (Rear View)

Item	Description	Part Number
1	Nut M14 — analog output	2940-0256
2	Washer — analog output	2190-0699
3	Standoff — remote connector	1251-7788
4	Standoff — GPIB connector	0380-0643
5	Power supply (behind rear panel)	0950-2528
6	Screw, M4, 7 mm lg — power supply	0515-0910
7	Washer — power supply	2190-0409

Control Module(B-Version)

Table 9

Control Module

Item	Description	Part Number
	Control module, replacement part including cable	G1323-67001
	Plastic housing kit, includes front, back and clamp	5062-8583
	CAN cable, Agilent 1100 module to control module	G1323-81600

Figure 28

Control Module

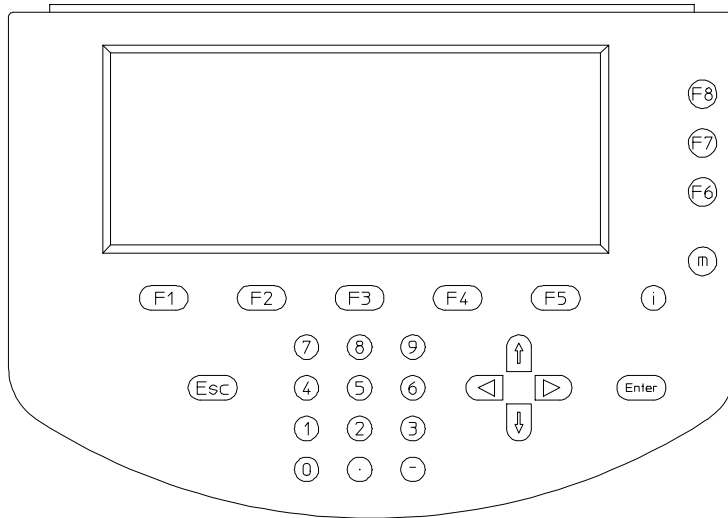

Solvent Cabinet

Table 10

Solvent Cabinet Parts

Item	Description	Part Number
1	Solvent cabinet, including all plastic parts	5062-8581
2	Name plate, Agilent 1100	5042-1312
3	Front panel, solvent cabinet	5062-8580
4	Leak pan, solvent cabinet	5042-1307
5	Bottle amber	9301-1450
6	Bottle transparent	9301-1420
7	Bottle-head assembly, see page 169	G1311-60003

Figure 29

Solvent Cabinet Parts

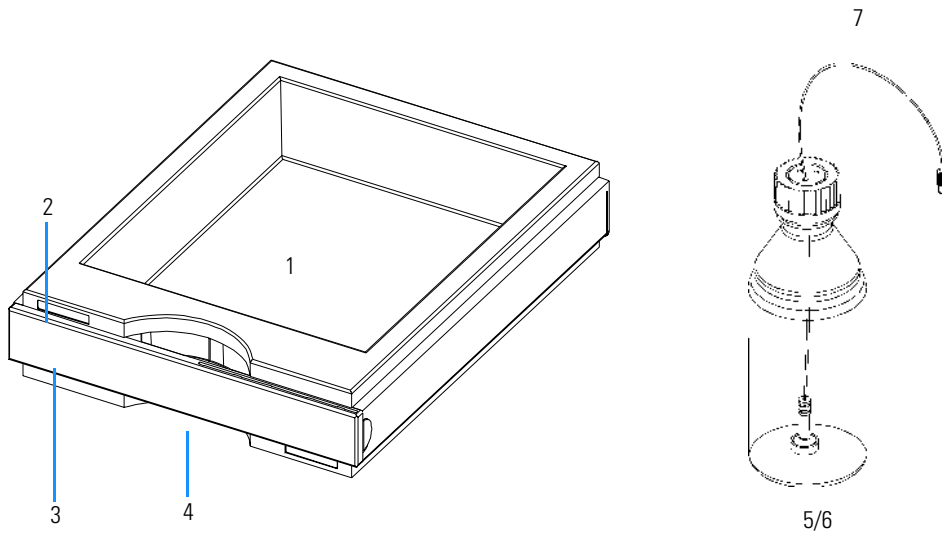

Bottle-Head Assembly

Table 11

Bottle-Head Assembly Parts

Item	Description	Part Number
	Complete assembly	G1311-60003
1	Ferrules with lock ring	5063-6598 (10x)
2	Tube screw	5063-6599 (10x)
3	Wire marker	No part number
4	Solvent tubing, 5 m	5062-2483
5	Frit adapter (pack of 4)	5062-8517
6	Solvent inlet filter	5042-1347

Figure 30

Bottle-Head Assembly Parts

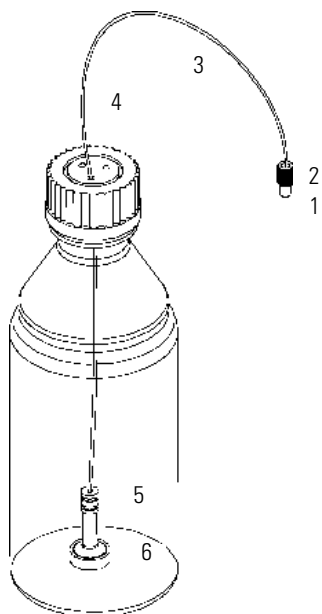

Hydraulic Path with Solvent Selection Valve

Table 12

Hydraulic Path with Solvent Selection Valve

Item	Description	Part Number
1	Capillary, mixer to purge valve	G1312-67308
2	Capillary, outlet ball valve to piston 2	G1312-67300
3	Mixer	G1312-87330
4	Bottle-head assembly	G1311-60003
5	Capillary, damper to mixer	G1312-67307
6	Restriction capillary	G1312-67304
7	Mixing capillary	G1312-67302
8	Connection tube	G1311-67304
9	Capillary, pump to injector device	G1312-67305
	Capillary, pump to thermostatable autosampler	G1329-87300
10	Waste tube, 5 m	5062-2461
*	Capillary, damper to purge valve	G1312-67301

* Capillary needed when pump used without mixer installed

Hydraulic Path with Solvent Selection Valve

Figure 31

Hydraulic Path with Solvent Selection Valve

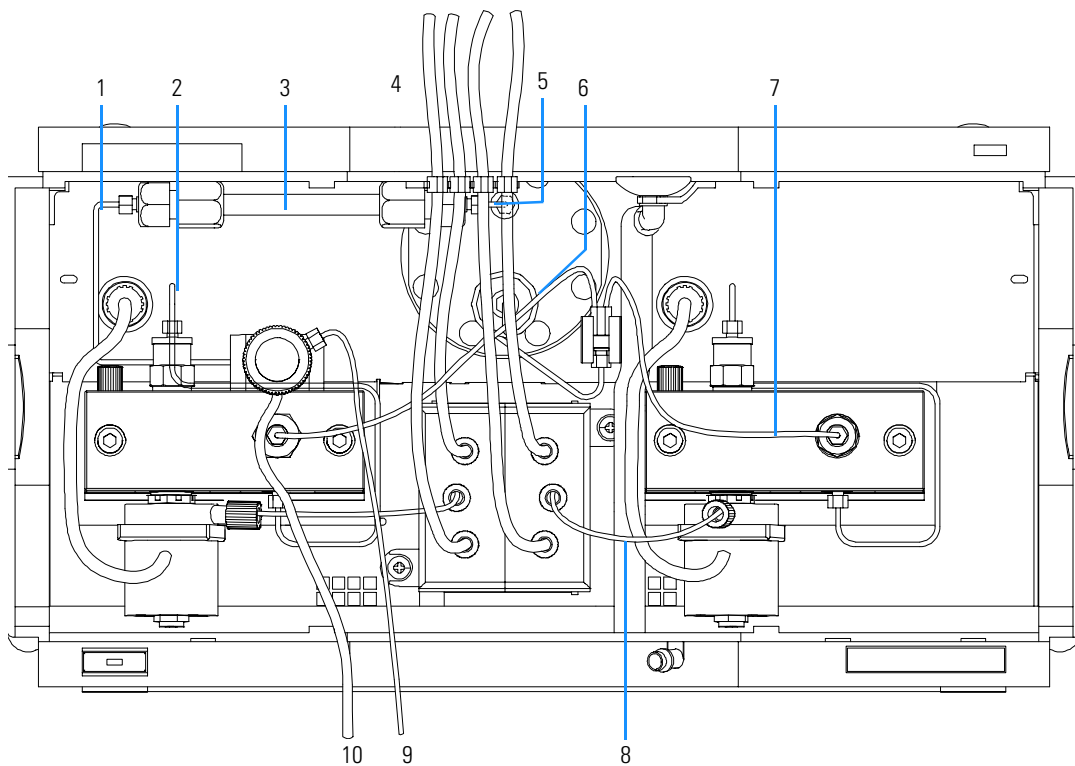

Hydraulic Path without Solvent Selection Valve

Table 13

Hydraulic Path without Solvent Selection Valve

Item	Description	Part Number
1	Capillary, mixer to purge valve	G1312-67308
2	Capillary, outlet ball valve to piston 2	G1312-67300
3	Mixer	G1312-87330
4	Bottle-head assembly	G1311-60003
5	Capillary, damper to mixer	G1312-67307
6	Restriction capillary	G1312-67304
7	Mixing capillary	G1312-67302
8	Capillary, pump to injection device	G1312-67305
	Capillary, pump to thermostatable autosampler	G1329-87300
9	Waste tube, 5 m	5062-2461
10	Adapter, AIV to bottle-head assembly	0100-1847
*	Capillary, damper to purge valve	G1312-67301

* Capillary needed when pump used without mixer installed

Hydraulic Path without Solvent Selection Valve

Figure 32

Hydraulic Path without Solvent Selection Valve

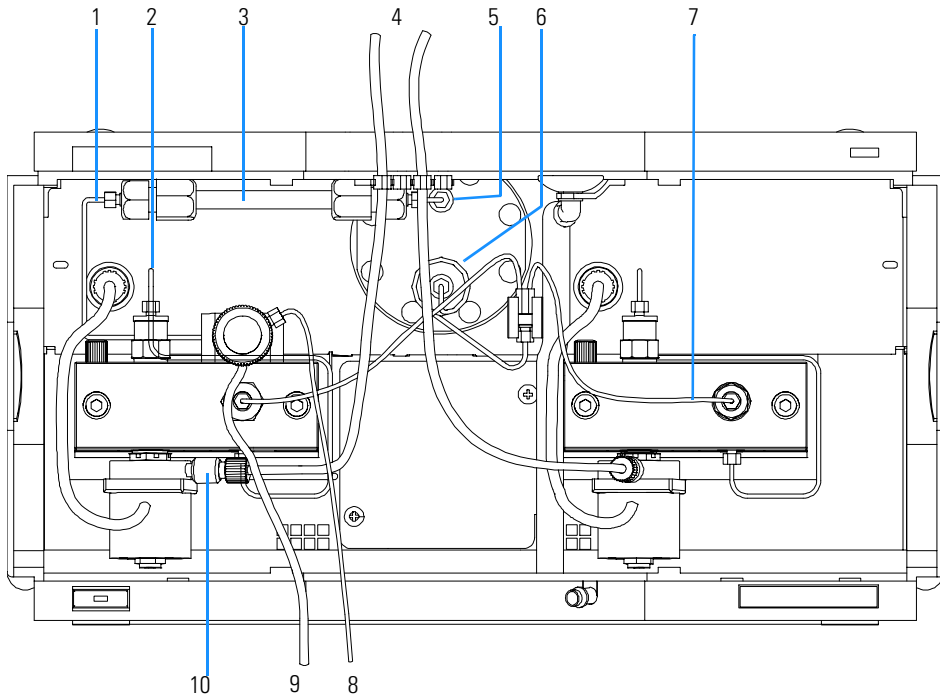

Cover Parts

Table 14

Cover Parts

Item	Description	Part Number
1	Plastic cover kit (includes top, base and both sides)	G1312-68703
2	Front plate	G1312-60011
3	Logo plate, Agilent 1100	5042-1312

Figure 33

Cover Parts

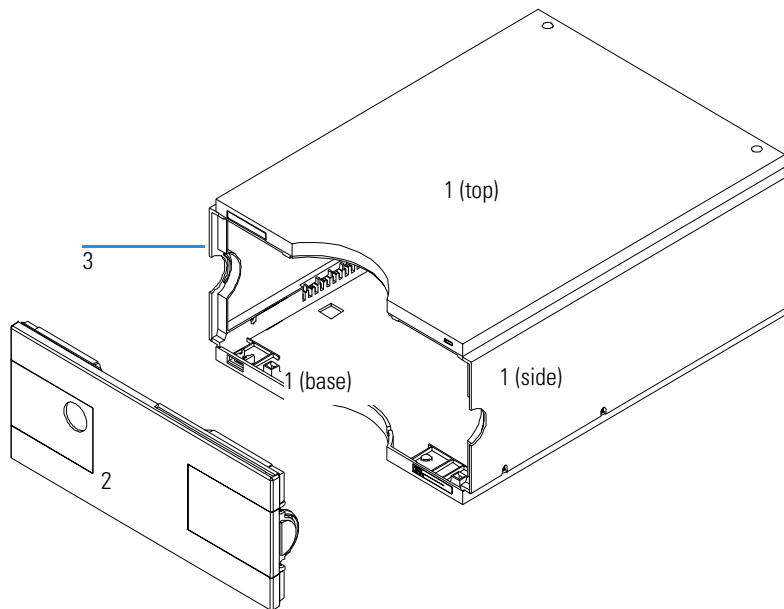

Sheet Metal Kit

Table 15

Sheet Metal Kit

Item	Description	Part Number
1	Sheet metal kit, includes top, base and Z-panel	G1312-68701
2*	Screw, for cover and Z-Panel	5022-2112
3*	Board cover	5001-3772

* Included in item 1

Figure 34

Sheet Metal Kit

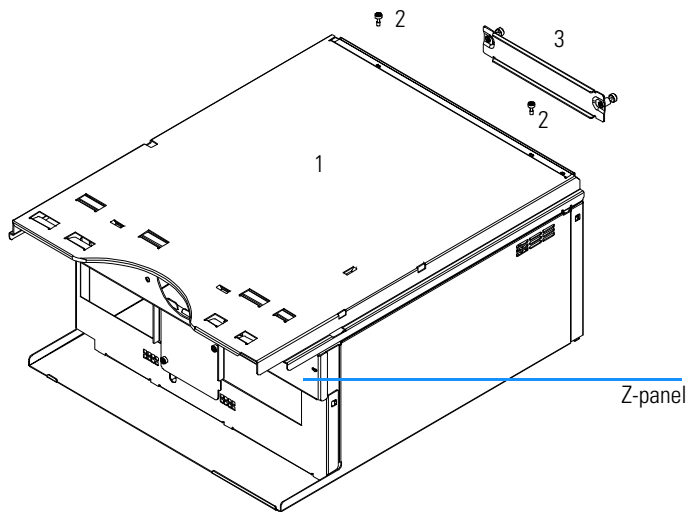

Foam Parts

Table 16

Foam Parts

Item	Description	Part Number
1	Foam kit, including upper and lower foam	G1312-68702
2	Bushing, for pump drive	1520-0404
3	Board guide	5041-8395

Figure 35

Foam Parts

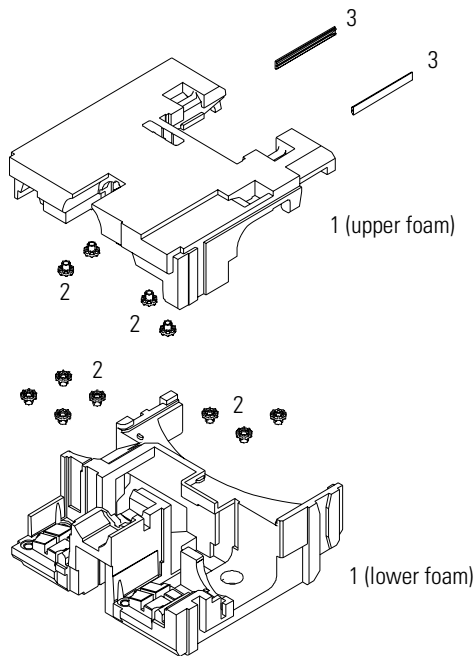

Power and Status Light Pipes

Table 17

Power and Status Light Pipes

Item	Description	Part Number
1	Power switch coupler	5041-8383
2	Light pipe — power switch	5041-8382
3	Power switch button	5041-8381
4	Light pipe — status lamp	5041-8384

Figure 36

Power and Status Light Pipes

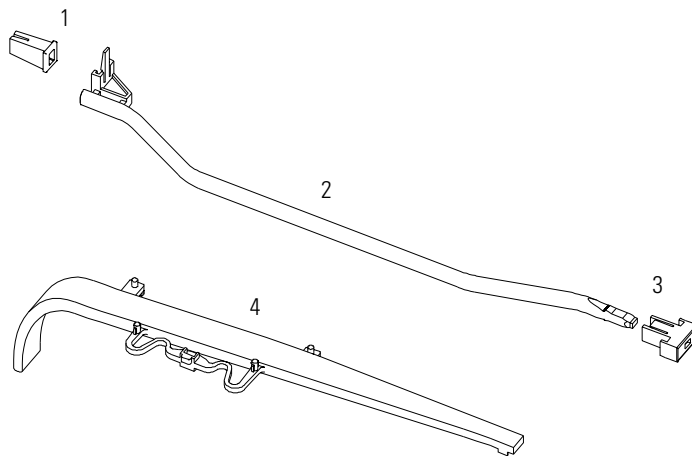

Leak Parts

Table 18

Leak Parts

Item	Description	Part Number
1	Leak sensor	5061-3356
2	Tube clip	5041-8387
3	Leak plane, pump	5041-8390
4	Leak funnel	5041-8388
5	Holder, leak funnel	5041-8389
6	Corrugated waste tube (reorder pack), 5m	5062-2463

Figure 37

Leak Parts

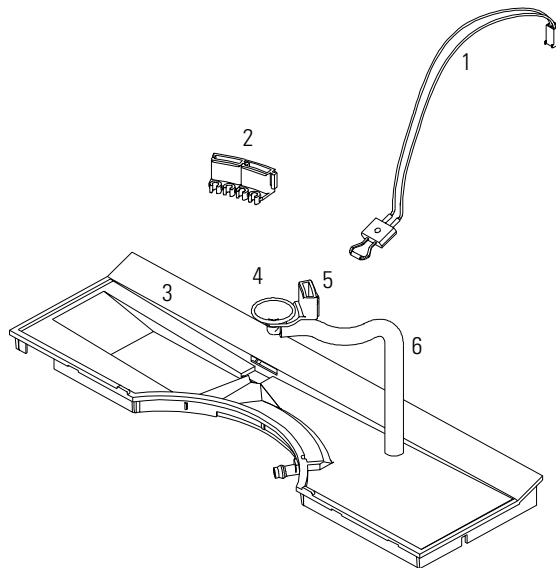

Pump-Head Assembly

Table 19

Pump-Head Assembly		
Item	Description	Part Number
	Complete assembly, included items marked with (*)	G1311-60004
1*	Sapphire plunger	5063-6586
2*	Plunger housing (including springs)	G1311-60002
3*	Support ring	5001-3739
4*	Seal (pack of 2) or Seal (pack of 2), for normal phase applications	5063-6589 0905-1420
5	Capillary outlet valve to piston 2	G1312-67300
6*	Pump chamber housing	G1311-25200
7	Active inlet valve (complete with cartridge) Replacement cartridge for active inlet valve	G1312-60010 5062-8562
8*	Screw M4 — purge valve holder	0515-0175
9	Purge valve holder	G1312-23200
10	Outlet ball valve	G1312-60012
11*	Screw lock	5042-1303
12	Apdater	G1312-23201
13	Purge valve assembly	G1311-60009
14*	Screw M5, 60 mm lg	0515-2118

Figure 38 **Pump-Head Assembly**

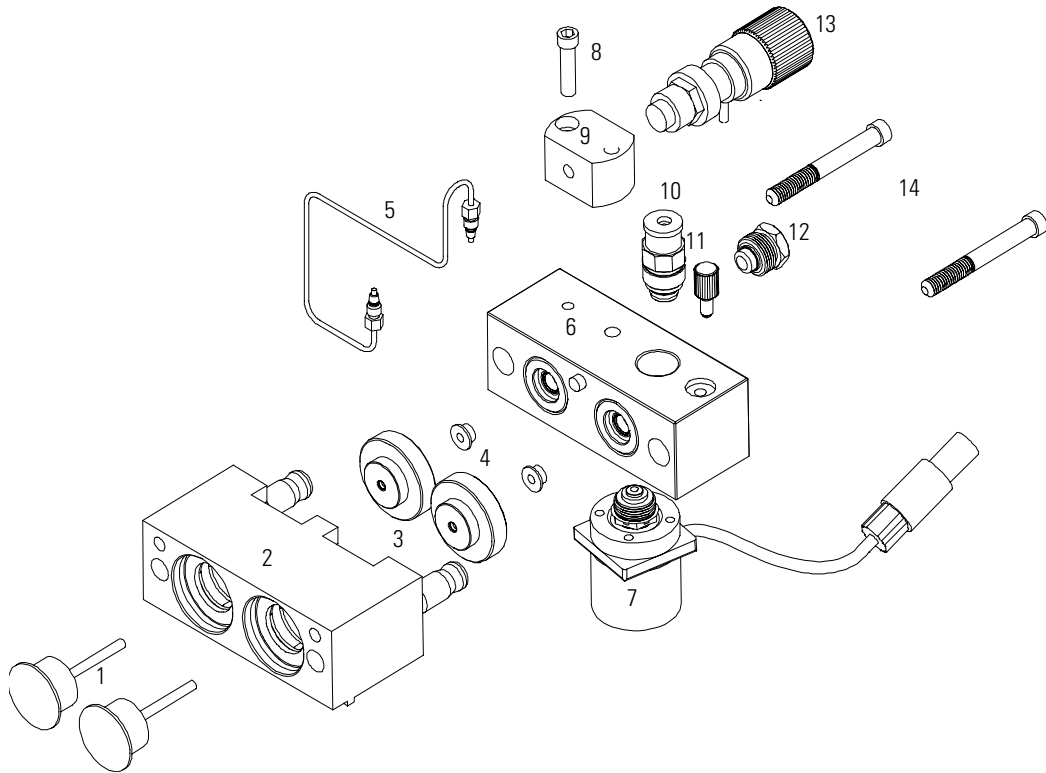

Pump-Head Assembly with Seal Wash

Table 20

Pump-Head Assembly with Seal Wash

Item	Description	Part Number
	Complete assembly, included items marked with (*)	G1311-60005
1*	Sapphire plunger	5063-6586
2*	Plunger housing (including springs)	G1311-60002
3*	Support ring, seal wash	5062-2465
4	Secondary seal	0905-1175
5	Wash tube (1.0 m)	0890-1764
6	Gasket, seal wash (pack of 6)	5062-2484
7	Seal keeper (pack of 2)	5001-3743
8*	Seal (pack of 2) or Seal (pack of 2), for normal phase applications (optional)	5063-6589 0905-1420
9	Capillary outlet valve to piston 2	G1312-67300
10*	Pump chamber housing	G1311-25200
11	Active inlet valve (complete with cartridge) Replacement cartridge for active inlet valve	G1312-60010 5062-8562
12*	Screw, purge-valve holder	0515-0175
13	Purge-valve holder	G1312-23200
14	Outlet ball valve	G1312-60012
15*	Screw lock	5042-1303
16	Apdater	G1312-23201
17	Purge-valve assembly	G1311-60009
18*	Screw M5 60 mm lg	0515-2118

Figure 39

Pump Head Assembly with Seal Wash Option

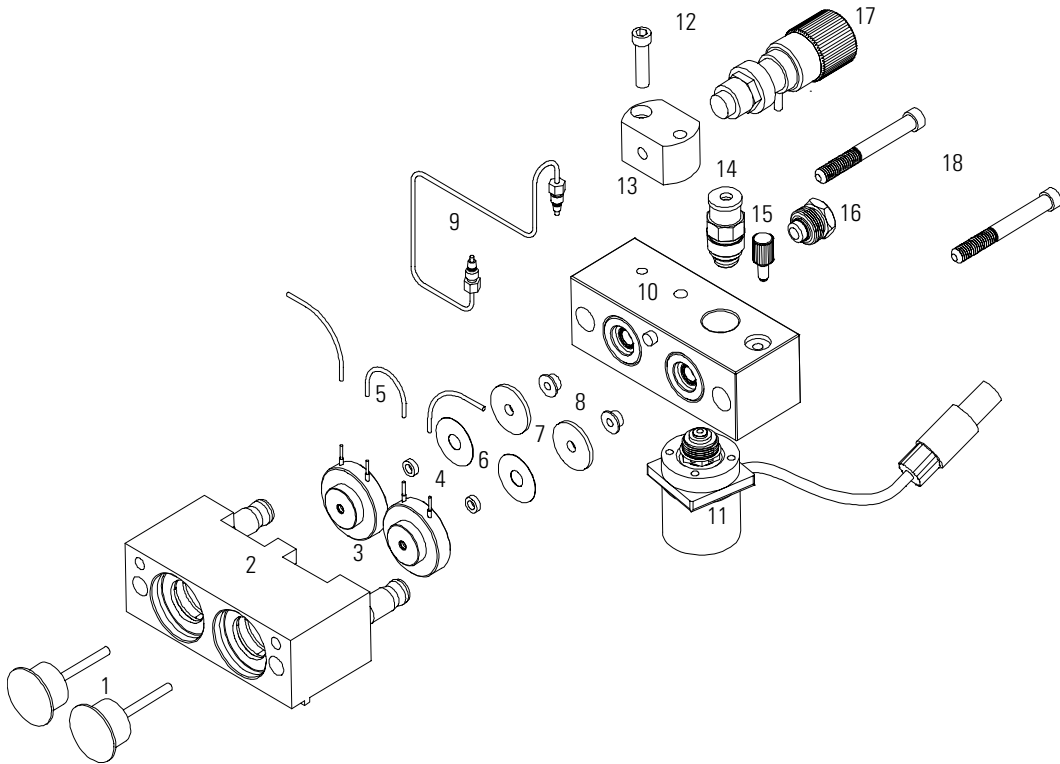

Outlet Ball Valve Assembly

Table 21

Outlet Ball Valve Assembly

Item	Description	Part Number
	Outlet ball valve — complete assembly	G1312-60012
1	Socket cap	G1312-21208
2	Housing screw	01018-22410
3	Outlet valve cartridge	No part number
4	Sieve (pack of 10)	5063-6505
5	Gold seal, outlet	5001-3707
6	Cap (pack of 4, reoder number)	5062-2485

Figure 40

Outlet Ball Valve

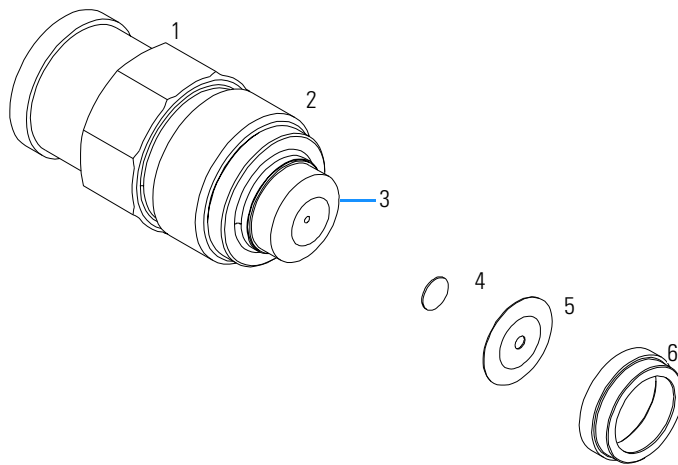

Purge-Valve Assembly

Table 22

Purge-Valve Assembly

Item	Description	Part Number
	Purge valve — complete assembly	G1311-60009
1	Valve body	No part number
2	PTFE frit (pack of 5)	01018-22707
3	Gold seal	5001-3707
4	Cap (pack of 4, reorder number)	5062-2485

Figure 41

Purge Valve

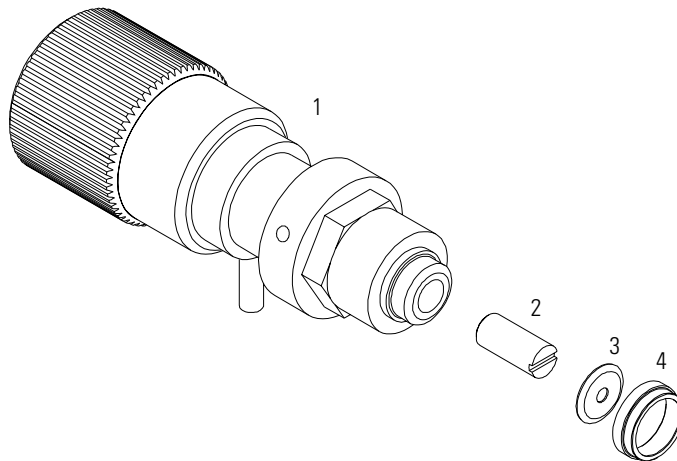

Active Inlet Valve Assembly

Table 23

Active Inlet Valve Assembly

Item	Description	Part Number
	Active inlet valve — complete assembly	G1312-60010
1	Valve body	No part number
2	Valve cartridge	5062-8562

Figure 42

Active Inlet Valve Assembly

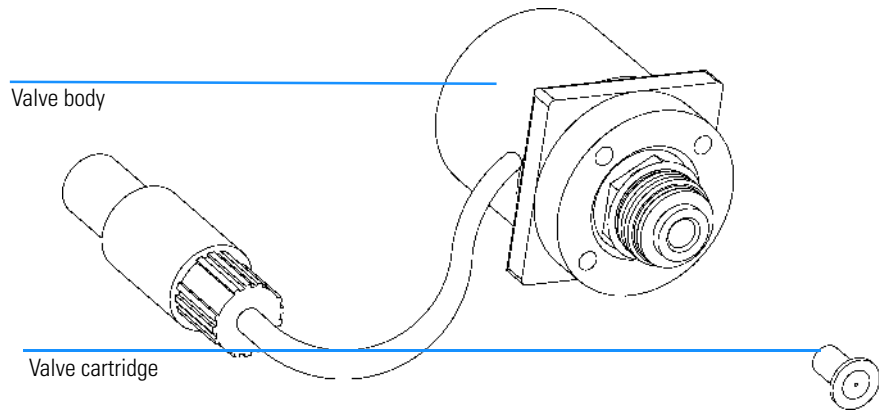

Accessory Kit G1311-68705

Table 24

Tools and Accessories

Description	Part Number
Wrench 14 mm	8710-1924
Insert tool seals	01018-23702
PTFE Frit (pack of 5)	01018-22707
Corrugated waste tube (1.2m)	no PN
Corrugated waste tube (reorder number), 5m	5062-2463
Velocity regulator	5062-2486
ESD wrist strap	9300-1408
Hex key 4 mm	8710-2392
Wrench 1/4 – 5/16 inch	8710-0510
Capillary, pump to injection device, 600 mm lg, id 0.17 mm	G1312-67305

Seal Wash Option 01018-68722

Table 25

Seal Wash Option

Description	Part Number
Support ring, seal wash (pack of 2)	5062-2465
Secondary seal (pre-installed in support ring)	0905-1175
Seal keeper (pack of 2)	5001-3743
Wash tube (1m)	0890-1764
Velocity regulator*	5062-2486
Seal insert tool	01018-23702
Seal (pack of 2)	5063-6589
Syringe	5062-8534
Syringe adapter	0100-1681
Knife	no PN
Sanding Paper	no PN

* Reorder number (pack of 3)

Cable Overview

WARNING

Never use cables other than the ones supplied by Agilent Technologies to ensure proper functionality and compliance with safety or EMC regulations.

Table 26

Cables Overview

Type	Description	Part Number
Analog cables	3390/2/3 integrators	01040-60101
	3394/6 integrators	35900-60750
	Agilent 35900A A/D converter	35900-60750
	General purpose (spade lugs)	01046-60105
Remote cables	3390 integrator	01046-60203
	3392/3 integrators	01046-60206
	3394 integrator	01046-60210
	3396A (Series I) integrator	03394-60600
	3396 Series II / 3395A integrator, see page 194	
	3396 Series III / 3395B integrator	03396-61010
	HP 1050 modules / HP 1046A FLD	5061-3378
	HP 1046A FLD	5061-3378
	Agilent 35900A A/D converter	5061-3378
	HP 1040 diode-array detector	01046-60202
	HP 1090 liquid chromatographs	01046-60202
	Signal distribution module	01046-60202
	BCD cables	3392/3 integrators

Table 26

Cables Overview, continued

Type	Description	Part Number
	3396 integrator	03396-60560
	General purpose (spade Lugs)	18594-60520
Auxiliary	Agilent 1100 Series vacuum degasser	G1322-61600
CAN cables	Agilent 1100 module to module, 0.5m lg	5181-1516
	Agilent 1100 module to module, 1m lg	5181-1519
	Agilent 1100 module to control module	G1323-81600
External contacts	Agilent 1100 Series interface board to general purpose	G1103-61611
GPIB cable	Agilent 1100 module to ChemStation, 1 m	10833A
	Agilent 1100 module to ChemStation, 2 m	10833B
RS-232 cable	Agilent 1100 module to a computer This kit contains a 9-pin female to 9-pin female Null Modem (printer) cable and one adapter.	34398A
LAN cable	Twisted pair cross over LAN cable, 10 feet long (for point to point connection)	5183-4649
	Category 5 UTP cable, 8 m long (for hub connections)	G1530-61480

Analog Cables



One end of these cables provides a BNC connector to be connected to Agilent 1100 Series modules. The other end depends on the instrument to which connection is being made.

Agilent 1100 to 3390/2/3 Integrators

Connector 01040-60101	Pin 3390/2/3	Pin Agilent 1100	Signal Name
	1	Shield	Ground
	2		Not connected
	3	Center	Signal +
	4		Connected to pin 6
	5	Shield	Analog -
	6		Connected to pin 4
	7		Key
	8		Not connected

Agilent 1100 to 3394/6 Integrators

Connector 35900-60750	Pin 3394/6	Pin Agilent 1100	Signal Name
	1		Not connected
	2	Shield	Analog -
	3	Center	Analog +

Analog Cables

Agilent 1100 to BNC Connector

Connector 8120-1840	Pin BNC	Pin Agilent 1100	Signal Name
	Shield	Shield	Analog -
	Center	Center	Analog +



Agilent 1100 to General Purpose

Connector 01046-60105	Pin 3394/6	Pin Agilent 1100	Signal Name
	1		Not connected
	2	Black	Analog -
	3	Red	Analog +

Remote Cables

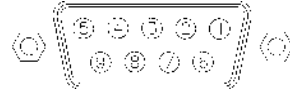

One end of these cables provides a Agilent Technologies APG (Analytical Products Group) remote connector to be connected to Agilent 1100 Series modules. The other end depends on the instrument to be connected to.

Agilent 1100 to 3390 Integrators

Connector 01046-60203	Pin 3390	Pin Agilent 1100	Signal Name	Active (TTL)
	2	1 - White	Digital ground	
	NC	2 - Brown	Prepare run	Low
	7	3 - Gray	Start	Low
	NC	4 - Blue	Shut down	Low
	NC	5 - Pink	Not connected	
	NC	6 - Yellow	Power on	High
	NC	7 - Red	Ready	High
	NC	8 - Green	Stop	Low
	NC	9 - Black	Start request	Low

Agilent 1100 to 3392/3 Integrators

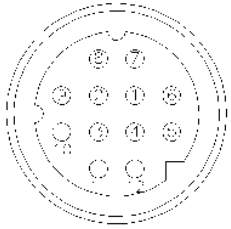
Connector 01046-60206	Pin 3392/3	Pin Agilent 1100	Signal Name	Active (TTL)
 <p>4 - Key</p>	3	1 - White	Digital ground	
	NC	2 - Brown	Prepare run	Low
	11	3 - Gray	Start	Low
	NC	4 - Blue	Shut down	Low
	NC	5 - Pink	Not connected	
	NC	6 - Yellow	Power on	High
	9	7 - Red	Ready	High
	1	8 - Green	Stop	Low
	NC	9 - Black	Start request	Low

Agilent 1100 to 3394 Integrators

Connector 01046-60210	Pin 3394	Pin Agilent 1100	Signal Name	Active (TTL)
	9	1 - White	Digital ground	
	NC	2 - Brown	Prepare run	Low
	3	3 - Gray	Start	Low
	NC	4 - Blue	Shut down	Low
	NC	5 - Pink	Not connected	
	NC	6 - Yellow	Power on	High
	5,14	7 - Red	Ready	High
	6	8 - Green	Stop	Low
	1	9 - Black	Start request	Low
13, 15		Not connected		

NOTE

START and STOP are connected via diodes to pin 3 of the 3394 connector.

Agilent 1100 to 3396A Integrators

Connector 03394-60600	Pin 3394	Pin Agilent 1100	Signal Name	Active (TTL)
	9	1 - White	Digital ground	
	NC	2 - Brown	Prepare run	Low
	3	3 - Gray	Start	Low
	NC	4 - Blue	Shut down	Low
	NC	5 - Pink	Not connected	
	NC	6 - Yellow	Power on	High
	5,14	7 - Red	Ready	High
	1	8 - Green	Stop	Low
	NC	9 - Black	Start request	Low
	13, 15		Not connected	

Agilent 1100 to 3396 Series II / 3395A Integrators

Use the cable 03394-60600 and cut pin #5 on the integrator side. Otherwise the integrator prints START; not ready.

Remote Cables

Agilent 1100 to 3396 Series III / 3395B Integrators

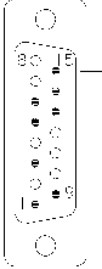
Connector 03396-61010	Pin 33XX	Pin Agilent 1100	Signal Name	Active (TTL)
	9	1 - White	Digital ground	
	NC	2 - Brown	Prepare run	Low
	3	3 - Gray	Start	Low
	NC	4 - Blue	Shut down	Low
	NC	5 - Pink	Not connected	
	NC	6 - Yellow	Power on	High
	14	7 - Red	Ready	High
	4	8 - Green	Stop	Low
	NC	9 - Black	Start request	Low
	13, 15		Not connected	

Agilent 1100 to HP 1050, HP 1046A or Agilent 35900 A/D Converters

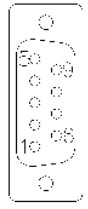
Connector 5061-3378	Pin HP 1050/...	Pin Agilent 1100	Signal Name	Active (TTL)
	1 - White	1 - White	Digital ground	
	2 - Brown	2 - Brown	Prepare run	Low
	3 - Gray	3 - Gray	Start	Low
	4 - Blue	4 - Blue	Shut down	Low
	5 - Pink	5 - Pink	Not connected	
	6 - Yellow	6 - Yellow	Power on	High
	7 - Red	7 - Red	Ready	High
	8 - Green	8 - Green	Stop	Low
	9 - Black	9 - Black	Start request	Low

Agilent 1100 to HP 1090 LC, HP 1040 DAD or Signal Distribution Module

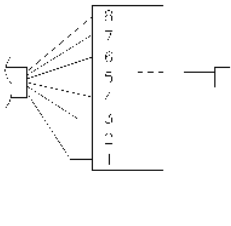
Connector 01046-60202	Pin HP 1090	Pin Agilent 1100	Signal Name	Active (TTL)
 <p>5 - Key</p>	1	1 - White	Digital ground	
	NC	2 - Brown	Prepare run	Low
	4	3 - Gray	Start	Low
	7	4 - Blue	Shut down	Low
	8	5 - Pink	Not connected	
	NC	6 - Yellow	Power on	High
	3	7 - Red	Ready	High
	6	8 - Green	Stop	Low
	NC	9 - Black	Start request	Low

Agilent 1100 to General Purpose

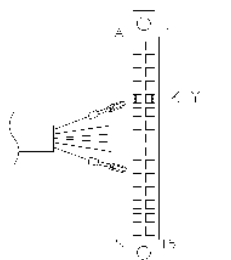
Connector 01046-60201	Pin Universal	Pin Agilent 1100	Signal Name	Active (TTL)
		1 - White	Digital ground	
		2 - Brown	Prepare run	Low
		3 - Gray	Start	Low
		4 - Blue	Shut down	Low
		5 - Pink	Not connected	
		6 - Yellow	Power on	High
		7 - Red	Ready	High
		8 - Green	Stop	Low
		9 - Black	Start request	Low

BCD Cables

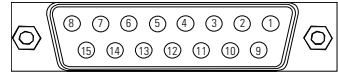

One end of these cables provides a 15-pin BCD connector to be connected to the Agilent 1100 Series modules. The other end depends on the instrument to be connected to.

Agilent 1100 to 3392/3 Integrators

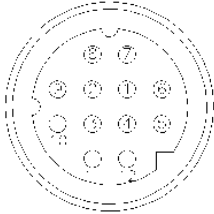
Connector 18584-60510	Pin 3392/3	Pin Agilent 1100	Signal Name	BCD Digit
 <p>6 - Key</p>	10	1	BCD 5	20
	11	2	BCD 7	80
	3	3	BCD 6	40
	9	4	BCD 4	10
	7	5	BCD 0\	1
	5	6	BCD 3	8
	12	7	BCD 2	4
	4	8	BCD 1	2
	1	9	Digital ground	
	2	15	+ 5 V	Low

BCD Cables

Agilent 1100 to 3396 Integrators

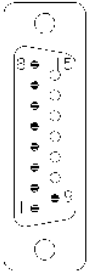
Connector 03396-60560	Pin 3392/3	Pin Agilent 1100	Signal Name	BCD Digit
	1	1	BCD 5	20
	2	2	BCD 7	80
	3	3	BCD 6	40
	4	4	BCD 4	10
	5	5	BCD 0\	1
	6	6	BCD 3	8
	7	7	BCD 2	4
	8	8	BCD 1	2
	9	9	Digital ground	
	NC	15	+ 5 V	Low

Agilent 1100 to General Purpose

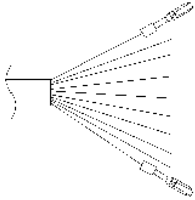
Connector 18594-60520	Wire Color	Pin Agilent 1100	Signal Name	BCD Digit
	Green	1	BCD 5	20
	Violet	2	BCD 7	80
	Blue	3	BCD 6	40
	Yellow	4	BCD 4	10
	Black	5	BCD 0\	1
	Orange	6	BCD 3	8
	Red	7	BCD 2	4
	Brown	8	BCD 1	2
	Gray	9	Digital ground	
	White	15	+5 Vt	Low

Auxiliary Cable

Auxiliary Cable



One end of this cable provides a modular plug to be connected to the Agilent 1100 Series vacuum degasser. The other end is for general purpose.

Agilent 1100 Series Degasser to general purposes

Connector G1322-81600	Color	Pin Agilent 1100	Signal Name
	White	1	Ground
	Brown	2	Pressure signal
	Green	3	
	Yellow	4	
	Grey	5	DC + 5 V IN
	Pink	6	Vent

CAN Cable

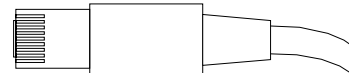

Both ends of this cable provide a modular plug to be connected to Agilent 1100 Series module's CAN-bus connectors.

Agilent 1100 module to module, 0.5m 5181-1516
lg

Agilent 1100 module to module, 1m lg 5181-1519

Agilent 1100 module to control module G1323-81600

External Contact Cable

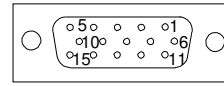

One end of this cable provides a 15-pin plug to be connected to Agilent 1100 Series module's interface board. The other end is for general purpose.

Agilent 1100 Series Interface Board to general purposes

Connector G1103-61611	Color	Pin Agilent 1100	Signal Name
	White	1	EXT 1
	Brown	2	EXT 1
	Green	3	EXT 2
	Yellow	4	EXT 2
	Grey	5	EXT 3
	Pink	6	EXT 3
	Blue	7	EXT 4
	Red	8	EXT 4
	Black	9	Not connected
	Violet	10	Not connected
	Grey/pink	11	Not connected
	Red/blue	12	Not connected
	White/green	13	Not connected
	Brown/green	14	Not connected
	White/yellow	15	Not connected

RS-232 Cable Kit

This kit contains a 9-pin female to 9-pin female Null Modem (printer) cable and one adapter. Use the cable and adapter to connect Agilent Technologies instruments with 9-pin male RS-232 connectors to most PCs or printers.

Agilent 1100 module to PC

RS-232 Cable Kit 34398A

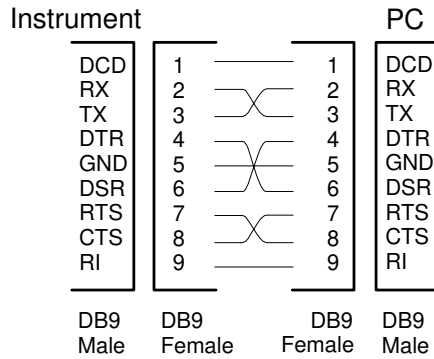

LAN Cables

Recommended Cables

For point to point connection (not using a network hub) use a twisted pair cross over LAN cable (P/N 5183-4649, 10 feet long).

For standard network connections using a hub use category 5 UTP cables, (P/N G1530-61480, 8 m long).

Introduction to the Binary Pump

An introduction to the pump, instrument overview, theory of operation, external communication and internal connectors

Introduction to the Binary Pump

The binary pump comprises two identical pumps integrated into one housing. It provides gradient generation by high-pressure mixing. Degassing is not included but a vacuum degasser is available as a separate product for applications that require best flow stability especially at low flow rates or maximum detector sensitivity. This is most likely required to run small internal diameter columns (2 mm and 1 mm i.d.) which require low flow rates. A solvent selection valve (optional) will allow to select a binary mixture (isocratic and gradient) from four independent solvent bottles. A continuous seal wash (optional) is available when the pump is used with concentrated buffer solutions.

Figure 43 Overview of the Binary Pump

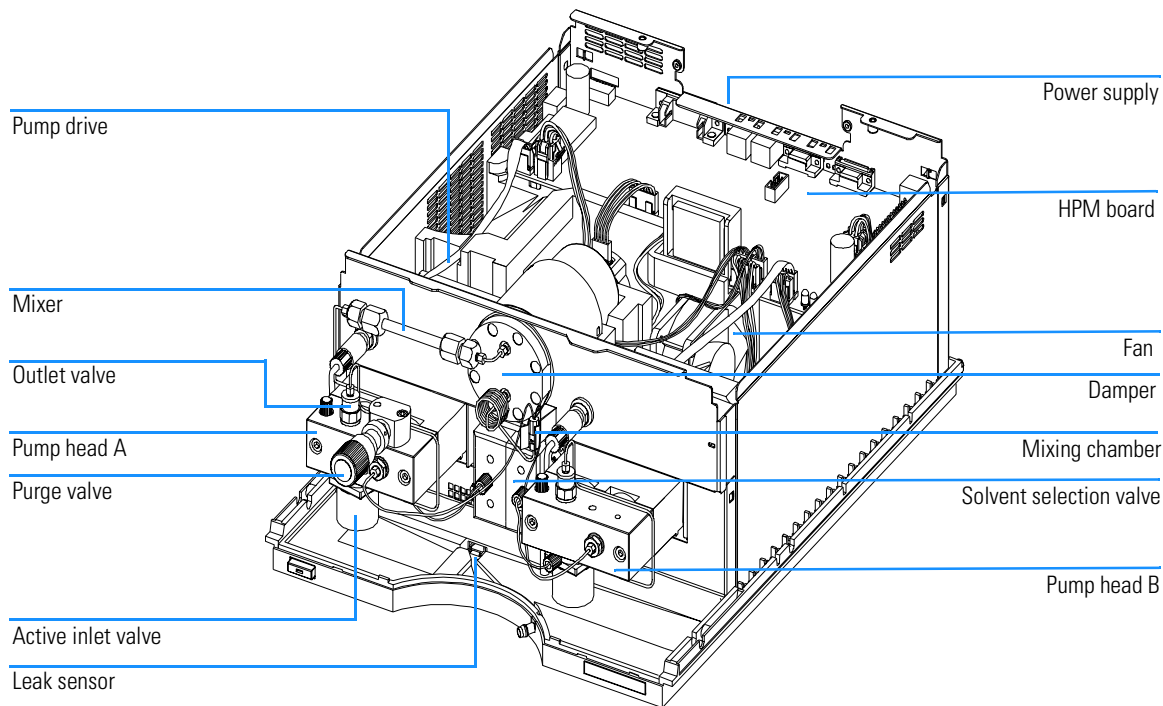

Overview

The binary pump is based on a two-channel, dual-piston in-series design which comprises all essential functions that a solvent delivery system has to fulfill. Metering of solvent and delivery to the high-pressure side are performed by two pump assemblies which can generate pressure up to 400 bar.

Each channel comprises a pump assembly including pump drive, pump head, active inlet valve which has a replaceable cartridge, and outlet valve. Both channels are connected in a low-volume mixing chamber which is connected by a capillary coil to a damping unit and a mixer. A purge valve including a PTFE frit is fitted at the pump outlet for convenient priming of the pumping system.

Figure 44 **The Hydraulic Path**

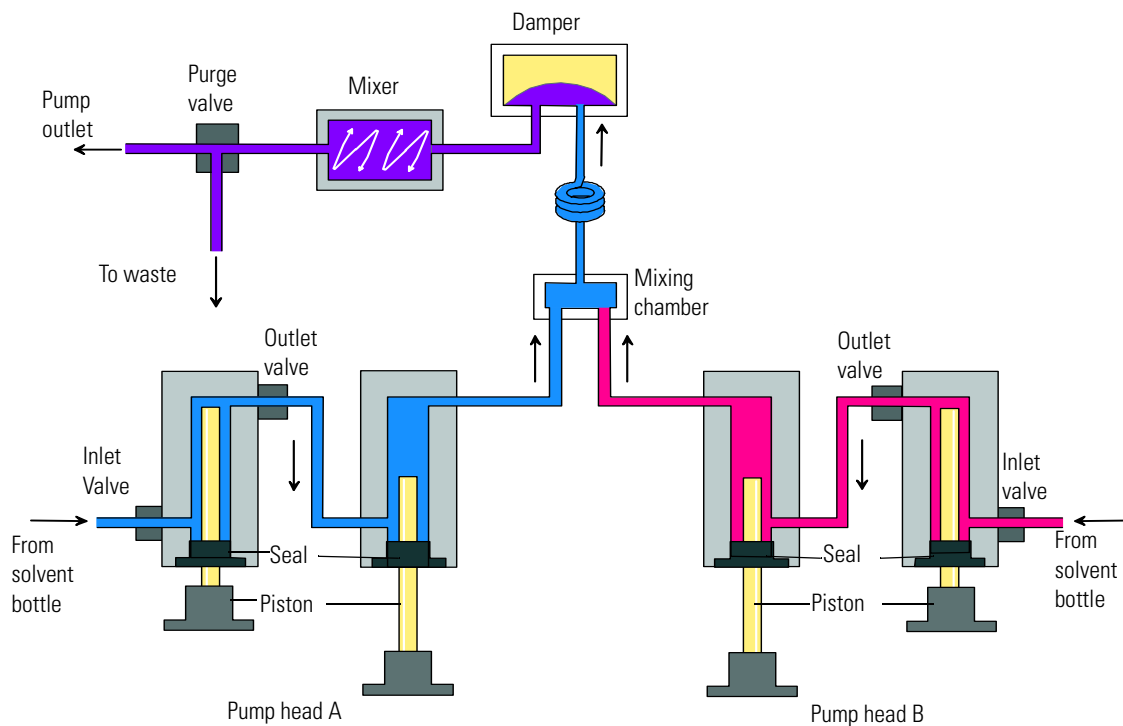

A continuous seal wash (optional) is available when the pump is used with buffer solutions.

How Does the Binary Pump Work?

The liquid runs from the solvent reservoir through an active inlet valve. Each side of the binary pump comprises two substantially identical pump units. Both pump units comprise a ball-screw drive and a pump head with two sapphire pistons for reciprocating movement.

Figure 45

Principle of Pump Unit

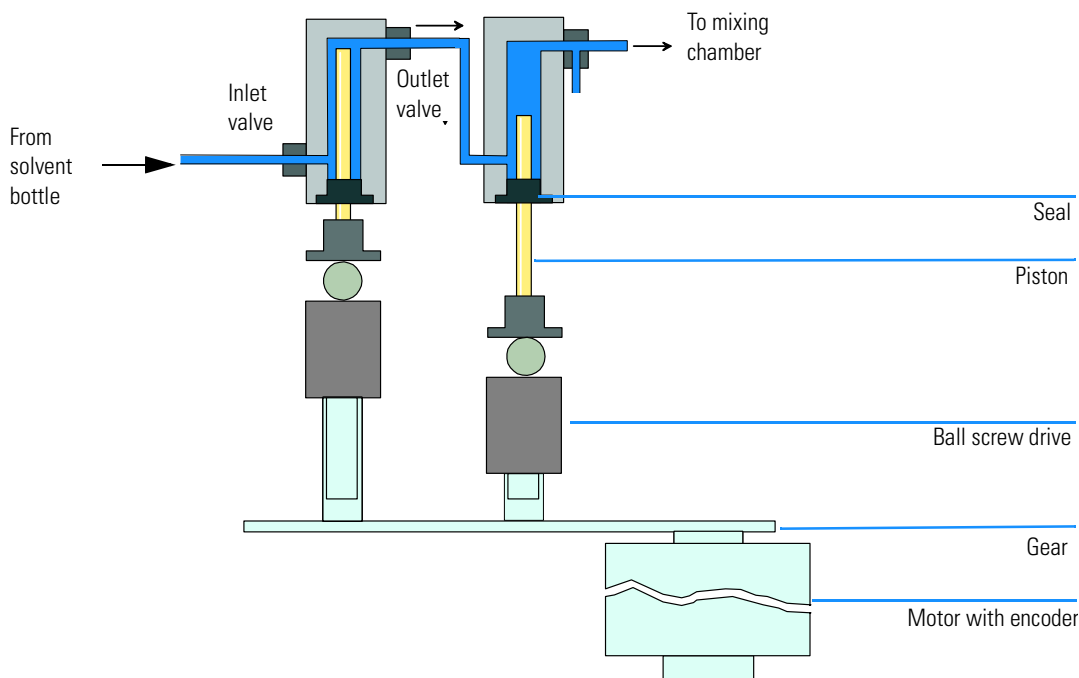

A servo-controlled variable reluctance motor drives the two ball-screw drives in opposite directions. The gears for the ball-screw drives have different circumferences (ratio 2:1) allowing the first piston to move at double the speed of the second piston. The solvent enters the pump heads close to the bottom limit and leaves it at its top. The outer diameter of the piston is smaller than the inner diameter of the pump-head chamber allowing the solvent to fill the gap in between. The first piston has a stroke volume in the

Introduction to the Binary Pump

range of 20 μl to 100 μl depending on the flow rate. The microprocessor controls all flow rates in a range of 1 $\mu\text{l}/\text{min}$ to 5 ml/min . The inlet of the first pumping unit is connected to the active inlet valve which is processor-controlled opened or closed allowing solvent to be drawn into the first pump unit.

The outlet of the pump unit is connected directly to the second pump unit. The outlet of the second pump units are connected via a small mixing chamber, a coil and the damping unit to the purge valve assembly. The outlet of the purge valve assembly is then connected to the following chromatographic system.

When turned on, the pump runs through an initialization procedure to determine the upper dead-center of the first piston of both pump channels. The first piston moves slowly upwards to the mechanical stop of the pump head and from there it moves back a predetermined path length. The controller stores this piston position in memory. After this initialization the pump starts operation with the set parameters for the two pump channels.

The active inlet valve is opened and the down moving piston draws solvent into the first pump head. At the same time the second piston is moving upwards delivering into the system. After a controller defined stroke length (depending on the flow rate) the drive motors are stopped and the active inlet valve is closed. The motor direction is reversed and moves the first piston up until it reaches the stored upper limit and at the same time moving the second piston downwards.

Then the sequence starts again moving the pistons up and down between the two limits. During the up movement of the first piston the solvent in the pump head is pressed through the outlet ball valve into the second pumping unit. The second piston draws in half of the volume displaced by the first piston and the remaining half volume is directly delivered into the system.

During the drawing stroke of the first piston, the second piston delivers the drawn volume into the system.

Table 27

Binary Pump Details

Delay volume	From mixing point to pump outlet, dependent on back pressure 180 – 480 µl without mixer 600 – 900 µl with mixer
--------------	---

Materials in contact with mobile phase

Pump head	SST, gold, sapphire, ceramic
Active Inlet Valve	SST, gold, sapphire, ruby, ceramic, PTFE
Outlet Valve	SST, gold, sapphire, ruby, tantalum
Adapter	SST, gold
Purge Valve	SST, gold, PTFE, ceramic
Damping Unit	Gold, SST

For pump specifications, see Chapter 8 “Specifications”.

How Does Compressibility Compensation Work?

The compressibility of the solvents in use will affect retention-time stability when the back pressure in the system changes (for example, aging of column). In order to minimize this effect, the pump provides a compressibility compensation feature which optimizes the flow stability according to the solvent type. The compressibility compensation is set to a default value and can be changed through the user interface.

Without a compressibility compensation the following will happen during a stroke of the first piston. The pressure in the piston chamber increases and the volume in the chamber will be compressed depending on backpressure and solvent type. The volume displaced into the system will be reduced by the compressed volume.

With a compressibility value set the processor calculates a compensation volume, that is depending on the backpressure in the system and the selected compressibility. This compensation volume will be added to the normal stroke volume and compensates the previous described *loss* of volume during the delivery stroke of the first piston.

How Does Variable Stroke Volume Work?

Due to the compression of the pump-chamber volume each piston stroke of the pump will generate a small pressure pulsation, influencing the flow ripple of the pump. The amplitude of the pressure pulsation is mainly dependent on the stroke volume and the compressibility compensation for the solvent in use. Small stroke volumes will generate less pressure pulsations than higher stroke volumes at same flow rates. In addition the frequency of the pressure pulsations will be higher. This will decrease the influence of flow pulsations on quantitative results.

In gradient mode smaller stroke volumes resulting in less flow ripple will improve composition ripple.

The binary pump uses a processor-controlled ball screw system to drive its pistons. The normal stroke volume is optimized for the selected flow rate. Small flow rates use a small stroke volume while higher flow rates use a higher stroke volume.

The stroke volume for the pump is set to AUTO mode. This means that the stroke is optimized for the flow rate in use. A change to larger stroke volumes is possible but not recommended.

Electrical Connections

- The GPIB connector is used to connect the binary pump with a computer. The address and control switch module next to the GPIB connector determines the GPIB address of your binary pump. The switches are preset to a default address (see Table 31 or see Table 35) and is recognized once after power on.
- The CAN bus is a serial bus with high-speed data transfer. The two connectors for the CAN bus are used for internal Agilent 1100 Series module data transfer and synchronization.
- One analog output provides a signal for integrators or data handling systems.
- The REMOTE connector may be used in combination with other analytical instruments from Agilent Technologies if you want to use features such as common shut down, prepare, and so on.
- The RS-232 connector may be used to control the binary pump from a computer via RS-232 connection, using appropriate software. This connector needs to be activated by the configuration switch module next to the GPIB connector. The software needs the appropriate drivers to support this communication. See your software documentation for further information.
- The power input socket accepts a line voltage of 100 – 120 or 220 – 240 volts AC \pm 10 % with a line frequency of 50 or 60 Hz. Maximum power consumption is 220 VA (Volt-Amps). There is no voltage selector on your binary pump because the power supply has wide-ranging capability. There are no externally accessible fuses, because automatic electronic fuses are implemented in the power supply. The security lever at the power input socket prevents that the binary pump cover is taken off when line power is still connected.
- The interface board slot is used for external contacts, BCD output and for future use.

WARNING

Never use cables other than the ones supplied by Agilent Technologies to ensure proper functionality and compliance with safety or EMC regulations.

Figure 46 **Electrical Connections to the Binary Pump**

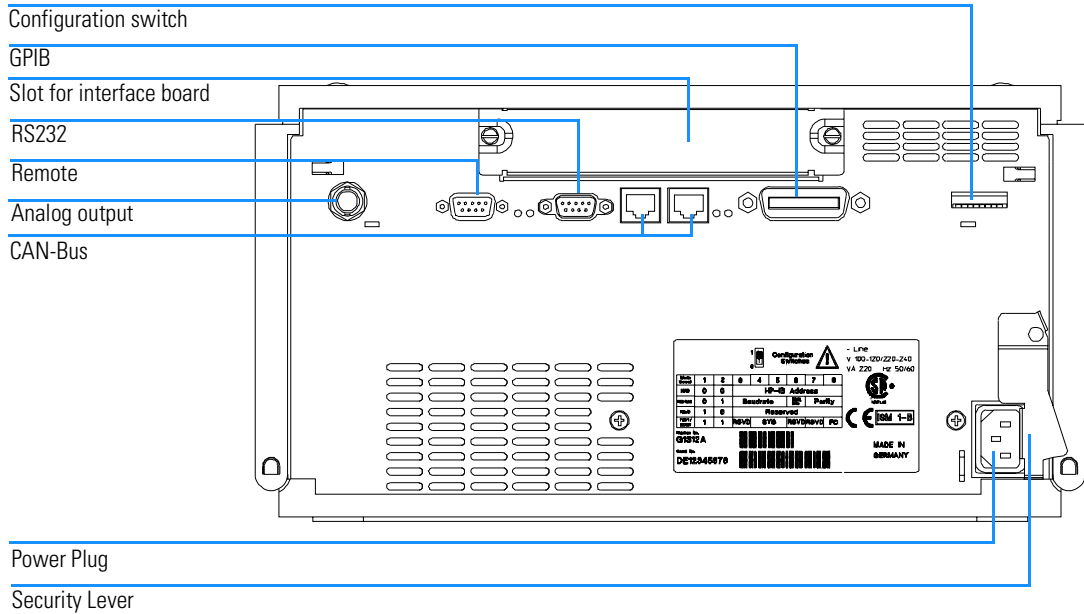

WARNING

To disconnect the binary pump from line, unplug the power cord. The power supply still uses some power, even if the power switch on the front panel is turned off.

Instrument Layout

The industrial design of the module incorporates several innovative features. It uses Agilent's E-PAC concept for the packaging of electronics and mechanical assemblies. This concept is based upon the use of expanded polypropylene (EPP) layers foam plastic spacers in which the mechanical and electronic boards components of the module are placed. This pack is then housed in a metal inner cabinet which is enclosed by a plastic external cabinet. The advantages of this packaging technology are:

- virtual elimination of fixing screws, bolts or ties, reducing the number of components and increasing the speed of assembly/disassembly,
- the plastic layers have air channels molded into them so that cooling air can be guided exactly to the required locations,
- the plastic layers help cushion the electronic and mechanical parts from physical shock, and
- the metal inner cabinet shields the internal electronics from electromagnetic interference and also helps to reduce or eliminate radio frequency emissions from the instrument itself.

Early Maintenance Feedback (EMF)

Maintenance requires the exchange of components in the flow path which are subject to mechanical wear or stress. Ideally, the frequency at which components are exchanged should be based on the intensity of usage of the instrument and the analytical conditions, and not on a predefined time interval. The early maintenance feedback (EMF) feature monitors the usage of specific components in the instrument, and provides feedback when the user-settable limits have been exceeded. The visual feedback in the user interface provides an indication that maintenance procedures should be scheduled.

EMF Counters

The binary pump provides a series of EMF counters for the left and right pump heads. Each counter increments with pump use, and can be assigned a maximum limit which provides visual feedback in the user interface when the limit is exceeded. Each counter can be reset to zero after maintenance has been done. The binary pump provides the following EMF counters:

- liquimeter pump A,
- seal wear pump A,
- liquimeter pump B, and
- seal wear pump B.

Liquimeters

The liquimeters display the total volume of solvent pumped by the left and right pump heads since the last reset of the counters. Both liquimeters can be assigned an EMF (maximum) limit. When the limit is exceeded, the EMF flag in the user interface is displayed.

Seal Wear Counters

The seal wear counters display a value derived from pressure and flow (both contribute to seal wear). The values increment with pump usage until the counters are reset after seal maintenance. Both seal wear counters can be assigned an EMF (maximum) limit. When the limit is exceeded, the EMF flag in the user interface is displayed.

Using the EMF Counters

The user-settable EMF limits for the EMF counters enable the early maintenance feedback to be adapted to specific user requirements. The wear of pump components is dependent on the analytical conditions, therefore, the definition of the maximum limits need to be determined based on the specific operating conditions of the instrument.

Setting the EMF Limits

The setting of the EMF limits must be optimized over one or two maintenance cycles. Initially, no EMF limit should be set. When performance indicates maintenance is necessary, take note of the values displayed by liquimeters and seal wear counters. Enter these values (or values slightly less than the displayed values) as EMF limits, and then reset the EMF counters to zero. The next time the EMF counters exceed the new EMF limits, the EMF flag will be displayed, providing a reminder that maintenance needs to be scheduled.

The Electronics

The electronics are comprised of four main components:

- **The high pressure pump main board (HPM)**, see page 216.
- **Power supply**, see page 235.

Optional:

- **Interface board (BCD/external contacts)**, see page 223.
- **Interface board (LAN)**, see page 224.

High-Pressure Pump Main Board (HPM)

The board controls all information and activities of all assemblies within the binary pump. The operator enters parameters, changes modes and controls the binary pump through interfaces (CAN, GPIB or RS-232C), connected to the user-interfaces. Figure 47 and Figure 48 show block diagrams of this board.

ASIC — Application-Specific Integrated Circuit

The application-specific integrated circuit (ASIC) includes all digital logic for the core processor functions and also for module-specific functions.

Motor Drive

There are two identical motor drives for the drive assemblies. Each drive comprises motor_control, motor amplifier (drive) and current control.

Active Inlet Valve Drive

There are two identical valve drives for the two active inlet valves. Each drive comprises two amplifiers for the two contacts of valve solenoid.

Solvent Selection Valve Drive

This drive consists of amplifiers for the solenoids of the solvent selection valve.

Pressure Converter

This block comprises a filter and amplifier for the pressure-sensor-signal, a multiplexer, an A/D converter and an offset correction for the analog pressure output signal. The output voltage is 2 mV/bar.

Leak Converter

This block comprises a PTC for the leak identification and a NTC for the ambient temperature measurement. This assures that temperature changes are not identified as leak. A leak would cool down the PTC and its change in resistance results in a leak signal.

Fan Drive

The revolution of the fan is controlled by the main processor depending on the internal heat distribution in the binary pump. The fan provides a PWM signal which is proportional to the revolution. This fan status signal is used for diagnostics.

Electronic Fuses

The valve circuits are electronically fused on the board. Any error on the board or shortages of the valves will activate the electronic fuses that will switch off the supply voltage. This prevents the damage of components.

Onboard Battery

An onboard lithium battery buffers the electronic memories when the binary pump is turned off.

For safety information on lithium batteries, see “Lithium Batteries Information” on page 273.

Interfaces

The binary pump provides the following interfaces:

- two CAN connectors as interface to other Agilent 1100 Series modules,
- one GPIB connector as interface to the Agilent ChemStation,
- one RS-232C as interface to a computer,
- one REMOTE connector as interface to other Agilent products,
- one analog output for pressure signal output, and
- one optional interface board.

Figure 47 **Block Diagram Pump Controller Board**

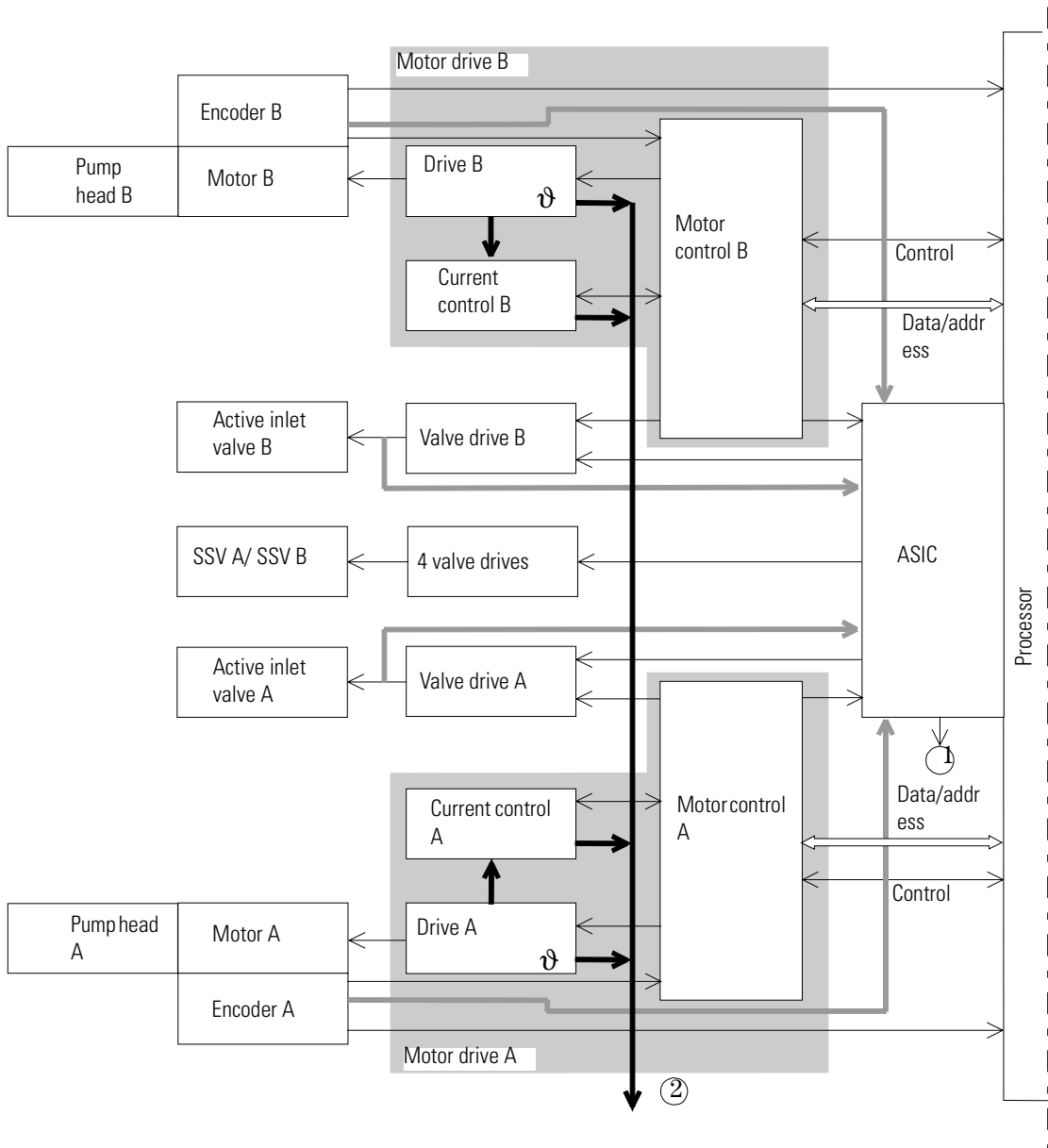

Figure 48 Block Diagram Pump Controller Board

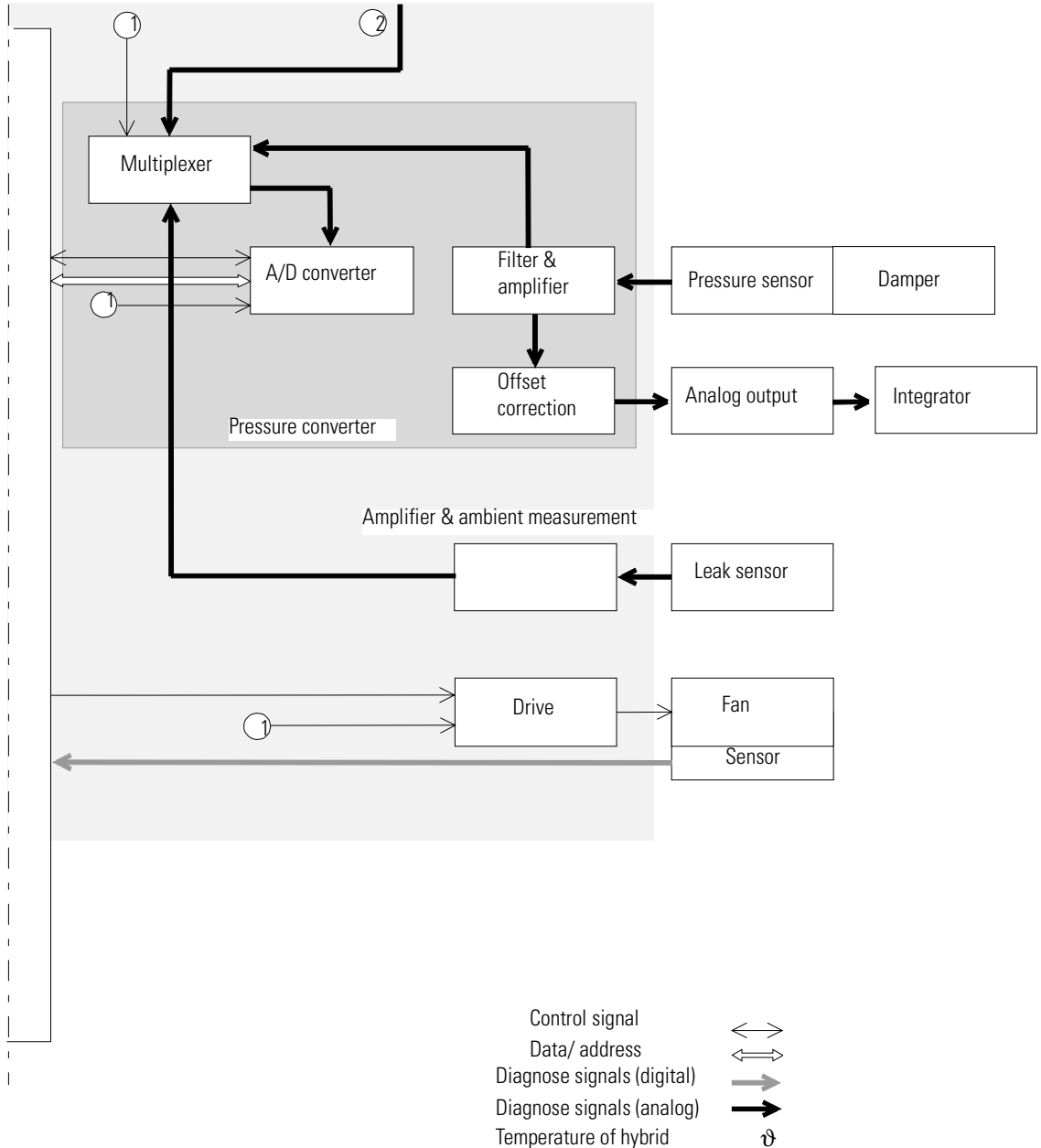
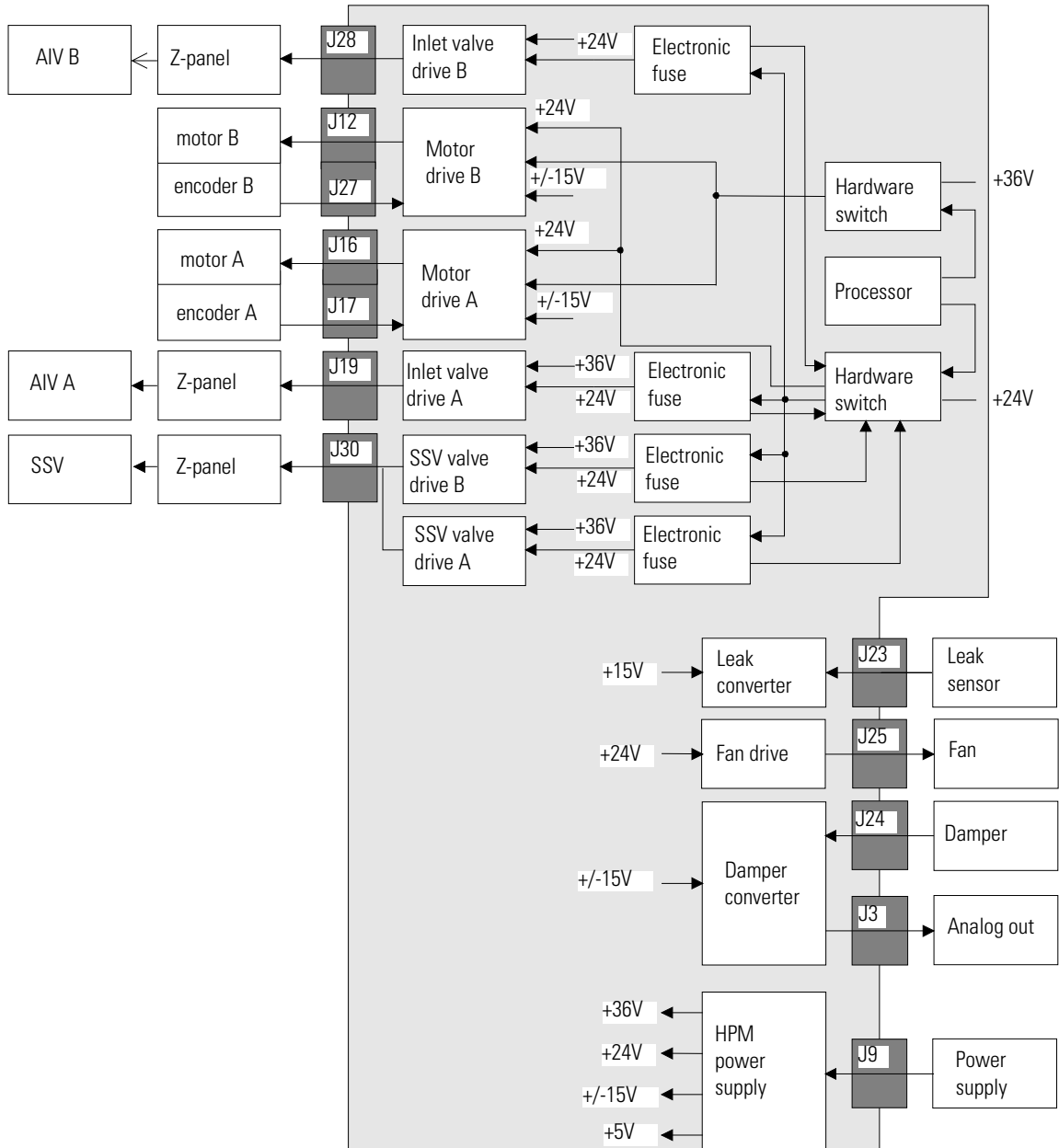

Figure 49 Interconnection Diagram HPM Board



Firmware Description

The firmware of the instrument consists of two independent sections:

- a non-instrument specific section, called ‘resident system’,
- an instrument specific section, called ‘main system’.

Resident System

This resident section of the firmware is identical for all Agilent 1100 series modules. Its properties are:

- the complete communication capabilities (GPIB, CAN, LAN and RS-232C),
- memory management,
- ability to update the firmware of the ‘main system’.

Main System

Its properties are:

- the complete communication capabilities (GPIB, CAN, LAN and RS-232C),
- memory management,
- ability to update the firmware of the ‘resident system’.

In addition the main system comprises the instrument functions that are divided into common functions like

- run synchronisation via APG remote
- error handling,
- diagnostic functions and so on,

or module specific functions like

- internal events such as motor control, flow rates and so on,
- calculation of compensation values for variable strokes and pressures.

Firmware Description

Firmware Updates

Firmware updates can be done using your user interface:

- handheld control module with files from a PC-card or
- Agilent ChemStation with files from floppy disk

The file naming conventions are:

xxxx-vvv.DLB, where

xxxx is the product number, e.g. 1312 for the G1312A Binary Pump), and vvv is the revision number, for example 200 is revision 2.00.

For instructions refer to your user interface.

NOTE

Update of main system can be done in the resident system only.

Update of the resident system can be done in the main system only.

Figure 50

Firmware Update Mechanism

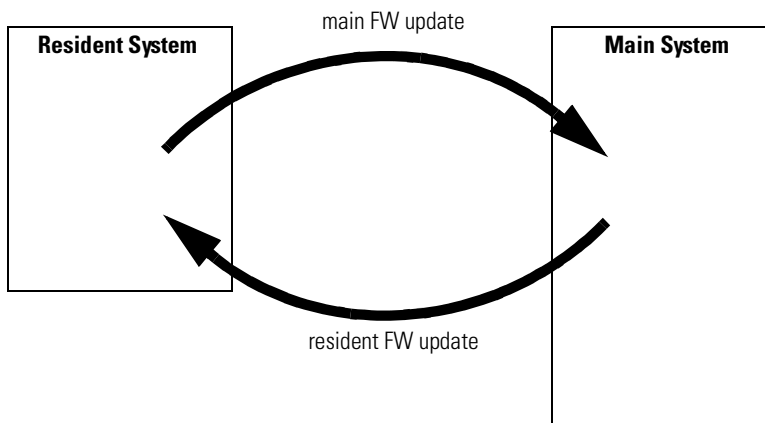

Optional Interface Boards

The Agilent 1100 Series modules have one optional board slot that allows to add an interface board to the modules.

Table 28

Optional Interface Boards

Description	Part Number
BCD Board	G1351-68701
Fuse 250 mA (four are on the board)	2110-0004
LAN Board (see next page for details)	

BCD Board

The BCD board provides a BCD output for the bottle number of the Agilent 1100 Series autosampler and four external contacts. The external contact closure contacts are relay contacts. The maximum settings are: 30 V (AC/DC); 250 mA (fused). There are general purpose cables available to connect the BCD output (see “BCD Cables” on page 197) and the external outputs (see “External Contact Cable” on page 200) to external devices.

Figure 51

Block Diagram BCD Board

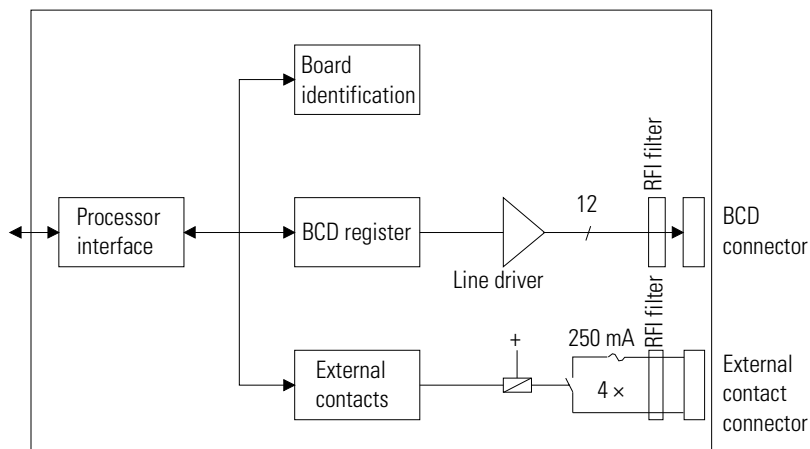

LAN Board

The HP LAN board is actually an HP JetDirect card, which is a network interface card used in HP printers.

NOTE

One board is required per Agilent 1100 stack. If the Agilent 1100 stack has a DAD, then the DAD MUST be the module used for LAN board installation. If no DAD is present a pump should be used for the LAN board installation.

NOTE

The LAN board can only be used together with:

A DAD/MWD/VWD/Pump/ALS with main board version G13XX-66520 and greater. An FLD/RID with main board version G13XX-66500 and greater.

a DOS-ChemStation software revision A.06.01 or above.

The following boards can be used with the Agilent 1100 modules.

Table 29

LAN Boards

Agilent Order Number	Supported networks
J4106A	Ethernet/802.3, RJ-45 (10Base-T)
J4105A	Token Ring/802.5, DB9, RJ-45 (10Base-T)
J4100A	Fast Ethernet, Ethernet/802.3, RJ-45 (10/100Base-TX) + BNC (10Base2)

NOTE

Minimum firmware of the LAN boards is A.05.05.

Recommended Cables

For point to point connection (not using a network hub) use a twisted pair cross over LAN cable (P/N 5183-4649, 10 feet long).

For standard network connections using a hub use category 5 UTP cables, (P/N G1530-61480, 8 m long).

Agilent 1100 Series Interfaces

The Agilent 1100 Series modules provide the following interfaces:

Table 30 **Agilent 1100 Series Interfaces**

Interface Type	Pumps	Autosampler	DA Detector MW Detector FL Detector	VW Detector RI Detector	Thermostatted Column Compartment	Vacuum Degasser
CAN	Yes	Yes	Yes	Yes	Yes	No
GPIB	Yes	Yes	Yes	Yes	Yes	No
RS-232C	Yes	Yes	Yes	Yes	Yes	No
APG Remote	Yes	Yes	Yes	Yes	Yes	Yes
Analog	Yes	No	2 ×	1 ×	No	Yes*
Interface board	Yes	Yes	Yes	Yes	No	No

* The vacuum degasser will have a special connector for specific use. For details, see the degasser manual.

- The CAN connectors serve as the interface between the Agilent 1100 Series modules themselves,
- the GPIB connector serves as the interface between an Agilent1100 module and the Agilent ChemStation,
- RS-232C provides an interface to a computer,
- the APG remote connector serves as the interface between the Agilent 1100 and other Agilent (APG remote compatible) products,
- the analog output connector(s) provide an analog signal output,
- the interface board slot (not common to all modules) provides specific interfacing needs (external contacts, BCD, LAN and so on).

For identification and location of the connectors see Figure 46 on page 211.

WARNING

Never use cables other than the ones supplied by Agilent Technologies to ensure proper functionality and compliance with safety or EMC regulations, see “Cable Overview” on page 188.

Analog Signal Output

The analog signal output can be distributed to a recording device. For details refer to the description of the main board of the module.

GPIB Interface

The GPIB connector is used to connect the module with a computer. The address and control switches next to the GPIB connector determine the GPIB address of your module. The switches are preset to a default address and recognized by the operating software from Agilent Technologies.

Table 31

Default GPIB Addresses

G131x Pumps	22	DAD (HP 1040)	15
G1313 Autosampler	28	FLD (HP 1046)	12
G1327 Thermostatted Sampler	28	ECD (Agilent 1049)	11
G1316 Column Compartment	27		
G1314 VWD	24	Pumps (HP 1050)	16
G1315/G1365 DAD/MWD	26	Autosampler (HP 1050)	18
G1321 FLD	23	VWD (HP 1050)	10
G1362 RID	29	DAD (HP 1050)	17
		MWD (HP 1050)	17
Agilent 8453A	25		

CAN Interface

The CAN is an inter module communication interface. It is a 2 wire serial bus system supporting high speed data communication and real-time requirements.

APG Remote Interface

The APG Remote connector may be used in combination with other analytical instruments from Agilent Technologies if you want to use features as common shut down, prepare, and so on.

Remote control allows easy connection between single instruments or systems to ensure coordinated analysis with simple coupling requirements.

The subminiature D connector is used. The binary pump provides one remote connector which is inputs/outputs (wired-or technique).

To provide maximum safety within a distributed analysis system, one line is dedicated to SHUT DOWN the system's critical parts in case any module detects a serious problem. To detect whether all participating modules are switched on or properly powered, one line is defined to summarize the POWER ON state of all connected modules. Control of analysis is maintained by signal readiness READY for next analysis, followed by START of run and optional STOP of run triggered on the respective lines. In addition PREPARE and START REQUEST may be issued. The signal level are defined as:

- standard TTL levels (low = 0.0 - 0.8 V, high = +2.0 - 5 V)
- fan-out is 10,
- input load is 1.7 kOhm against + 5 V, and
- output are open collector type, inputs/outputs (wired-or technique).

RS-232C

The RS-232C connector is used to control the instrument from a computer through RS-232C connection, using the appropriate software . This connector can be configured with the configuration switch module next to the GPIB

Table 32

APG Remote Signal Distribution

Pin	Signal	Description
1	DGND	Digital ground
2	PREPARE	(L) Request to prepare for analysis (for example, detector lamp on). Receiver is any module performing preanalysis activities.
3	START	(L) Request to start run / timetable. Receiver is any module performing run-time controlled activities.
4	SHUT DOWN	(L) System has serious problem (for example, leak: stops pump). Receiver is any module that needs to be shutdown to avoid a safety risk.
5		Not used
6	POWER ON	(H) All modules connected to system are switched on. Receiver is any module relying on operation of others.
7	READY	(H) System is ready for next analysis. Receiver is any sequence controller.
8	STOP	(L) Request to reach system ready state as soon as possible (for example, stop run, abort or finish and stop injection). Receiver is any module performing run-time controlled activities.
9	START REQUEST	(L) Request to start injection cycle. Receiver is the autosampler.

connector. The RS-232C is designed as DCE (data communication equipment) with a 9-pin male SUB-D type connector. The pins are defined as:

Table 33

RS-232C Connection Table

Pin	Direction	Function
1	In	DCD
2	In	RxD
3	Out	TxD
4	Out	DTR
5		Ground
6	In	DSR
7	Out	RTS
8	In	CTS
9	In	RI

Figure 52

RS-232 Cable

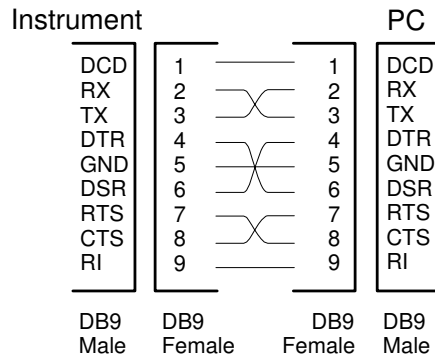

Setting the 8-bit Configuration Switch

The 8-bit configuration switch is located next to the GPIB connector. Switch settings provide configuration parameters for GPIB address, serial communication protocol and instrument specific initialization procedures.

Figure 53

8-bit Configuration Switch

Factory setting is shown for pump

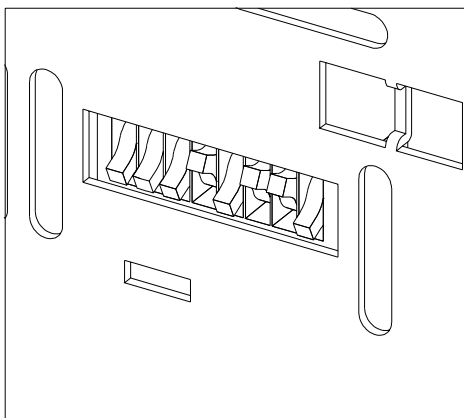

Table 34

8-bit Configuration Switch

Mode Select	1	2	3	4	5	6	7	8
GPIB	0	0		GPIB Address				
RS-232C	0	1	Baudrate			Data Bits	Parity	
Reserved	1	0	Reserved					
TEST/BOOT	1	1	RSVD	SYS		RSVD	RSVD	FC

Switches 1 and 2 define which set of parameters (for example, for GPIB, RS-232C, and so on) will be changed. Once the change has been completed, the instrument must be powered up again in order to store the values in the non-volatile memory.

Setting the 8-bit Configuration Switch

In the non-volatile memory the parameters are kept, regardless of whether you turn the instrument off and on again. They will be kept until the same set of parameters is subsequently changed and power is reset. All other previously stored configuration settings will still remain in the non-volatile memory.

In this way you can store more than one set of parameters using the same 8-bit configuration switch twice,, for example, for both GPIB and RS-232C.

GPIB Default Addresses

If you just want to change the GPIB address and need a detailed procedure, refer to the *Installing Your ChemStation System* handbook. Default GPIB address is set to the following addresses:

Table 35**Default Addresses for Agilent 1100 Series Modules**

Module	Address	Binary Address
Pump	22	00010110
FLD	12	00010111
VWD	24	00011000
Agilent 8453A	25	00011101
DAD/MWD	26	00011010
Column compartment	27	00011011
Autosampler	28	00011100
RID	29	00011101

where 0 means that the switch is down and 1 means that the switch is up

Communication Settings for RS-232C Communication

The communication protocol used in the instrument supports only hardware handshake (CTS/RTR).

Switches 1 in down and 2 in up position define that the RS-232C parameters will be changed. Once the change has been completed, the instrument must be powered up again in order to store the values in the non-volatile memory.

Setting the 8-bit Configuration Switch

Use the following tables for selecting the setting which you want to use for RS-232C communication. The number 0 means that the switch is down and 1 means that the switch is up.

Table 36**Communication Settings for RS-232C Communication**

Mode Select	1	2	3	4	5	6	7	8
RS-232	0	1	Baudrate			Data Bits	Parity	

Use the following tables for selecting the setting which you want to use for RS-232C communication. The number 0 means that the switch is down and 1 means that the switch is up

Table 37**Baudrate Settings**

Switches			Baud Rate	Switches			Baud Rate
3	4	5		3	4	5	
0	0	0	9600 (default)	1	0	0	9600
0	0	1	1200	1	0	1	14400
0	1	0	2400	1	1	0	19200
0	1	1	4800	1	1	1	38400

Table 38**Data Bit Settings**

Switch 6	Data Word Size
0	7 Bit Communication
1	8 Bit Communication

One start bit and one stop bit are always used (not selectable).

Per default, the module will turn into 19200 baud, 8 data bit with no parity.

Table 39

Parity Settings

Switches		Parity
7	8	
0	0	No Parity
0	1	Odd Parity
1	0	Even Parity

Forced Cold-Start Settings

Switches 1 and 2 do not force storage of this set of parameters in non-volatile memory. Returning the switches 1 and 2 to other positions (other than being both up) will allow for normal operation.

CAUTION

A forced cold start erases all methods and data stored in non-volatile memory. Exceptions are diagnose and repair logbooks which will not be erased.

If you use the following switch settings and power the instrument up again, a forced cold start has been completed.

Table 40

Forced Cold Start Settings

Mode Select	1	2	3	4	5	6	7	8
TEST/BOOT	1	1	0	0	0	0	0	1

To return to normal operation, set switches back to your GPIB or RS 232C configuration settings.

Stay Resident Settings

Firmware update procedures may require this mode in case of firmware loading errors.

Setting the 8-bit Configuration Switch

Switches 1 and 2 do not force storage of this set of parameters in non-volatile memory. Returning the switches 1 and 2 to other positions (other than being both up) will allow for normal operation.

If you use the following switch settings and power the instrument up again, the instrument firmware stays in the resident part, that is, it is not operable as a binary pump. It only uses basic functions of the operating system, for example, for communication, and so on.

Table 41

Stay Resident Settings

Mode Select	1	2	3	4	5	6	7	8
TEST/BOOT	1	1	0	0	1	0	0	0

To return to normal operation, set switches back to your GPIB or RS 232C configuration settings.

The Main Power Supply Assembly

The main power supply comprises a closed assembly (no component-level repair possibility).

The power supply provides all DC voltages used in the binary pump module. The line voltage can vary in a range from 100 – 120 or 220 – 240 volts AC $\pm 10\%$ and needs no manual setting.

Figure 54

Main Power Supply (MPS) Block Diagram

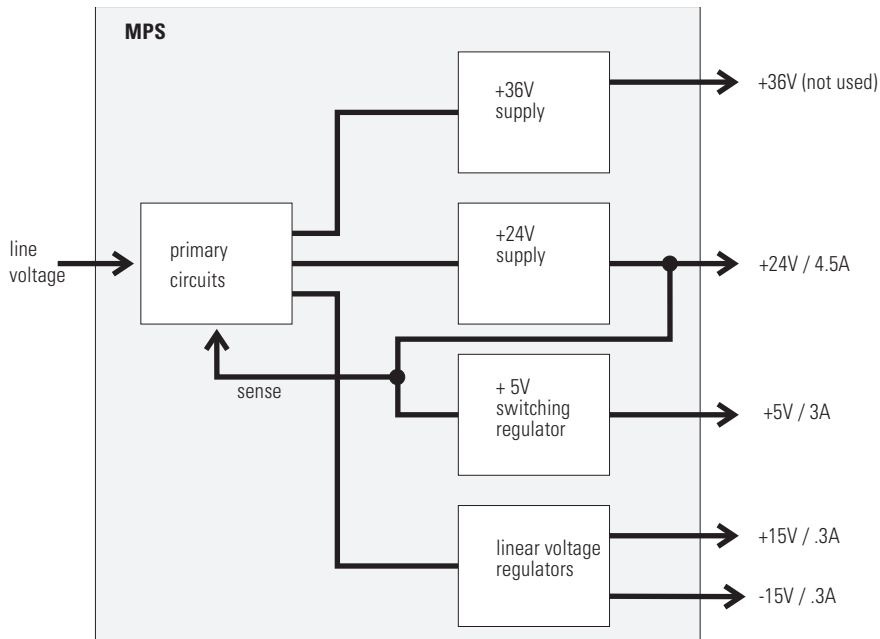

WARNING

To disconnect the instrument from line, unplug the power cord. The power supply still uses some power, even if the power switch on the front panel is turned off.

The Main Power Supply Assembly

No accessible hardware fuse is needed because the main power supply is safe against any short circuits or overload conditions on the output lines. When overload conditions occur, the power supply turns off all output voltages. Turning the line power off and on again resets the power supply to normal operation if the cause of the overload condition has been removed.

An over-temperature sensor in the main power supply is used to turn off output voltages if the temperature exceeds the acceptable limit (for example, if the cooling fan of the binary pump fails). To reset the main power supply to normal operating conditions, turn the binary pump off, wait until it is approximately at ambient temperature and turn the binary pump on again.

The following table gives the specifications of the main power supply.

Table 42**Main Power Supply Specifications**

Maximum power	220 W	Continuous output
Line Input	100 – 120 or 220 – 240 volts AC ± 10 %, line frequency of 50/60 Hz	Wide ranging
Output 1	+ 24 V / 4.5 A (maximum)	Total power consumption of +24V and +36V must not exceed 107 W
Output 2	+ 36 V / 2.5 A (maximum)	
Output 3	+ 5 V / 3 A	
Output 4	+ 15 V / 0.3 A	
Output 5	- 15 V / 0.3 A	

**Control Module Screens
for the Binary Pump**

Control Module Screens for the Binary Pump

This chapter is intended to introduce an operator to the screens available for operation of the Agilent 1100 binary pump with the Agilent 1100 control module.

Please use the manual of the control module for further detailed reference.

Major keys on the Agilent 1100 Control Module

ESC	Return to previous screen and scroll through top layer views (Analysis, Settings)
m	Open context sensitive menus
i	Information/help
Enter	Store changed parameters or execute the choice from a pull-down menu
Done	(If available) Activate settings of current screen
On/Off	Switch on pump
Start	Start a run
Plot	View the pressure readings
Views	Change between view of analysis - status - system screens

NOTE

The screens shown on the next pages are based on the following firmware revisions:

Control Module firmware revision B.01.01 (G1323B).

LC Module firmware revision 3.8x

NOTE

In case the control module's display seems to be frozen (hang-up due to a communication problem on the CAN bus, unplug the control module from the LC module and reconnect.

Screens available from the Analysis screen

The Analysis screen

This is the wake-up screen, if the Agilent 1100 binary pump is the only configured Agilent 1100 module. It is used to enter the most common pump method parameters.

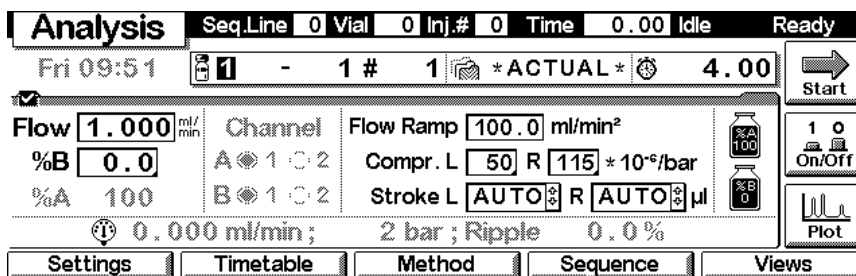

The **m**-key allows access to the context sensitive menu. **Date&Time** allows you to change time settings. **Print Screen** gives access to the print configuration screen. **About** tells you the current firmware revision and the serial# of your control module. **Setup view** leads you to add sections for additional Agilent 1100 modules. **Restart** re-boots the control module.

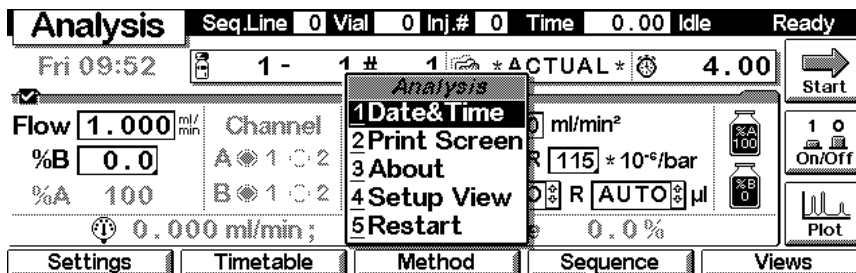

Control Module Screens for the Binary Pump
Screens available from the Analysis screen

Setup View

In the Setup view, modules can be added or removed to the view.

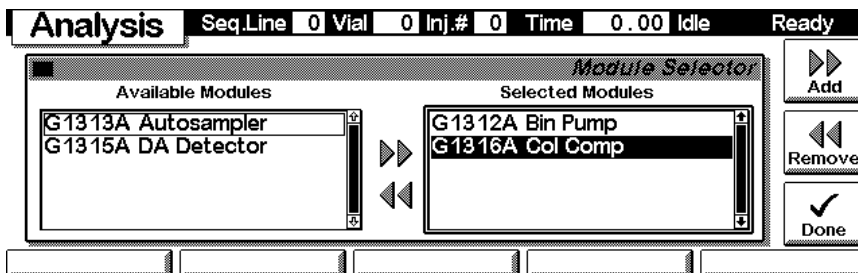

Here, e.g. the autosampler, the thermostatted column compartment and the DA detector parameters are shown on the display as well. The number of parameters on the display is restricted as additional modules are added. A maximum of 4 modules is shown automatically. If more modules are connected to the system, you have to choose 4 of them in Setup view.

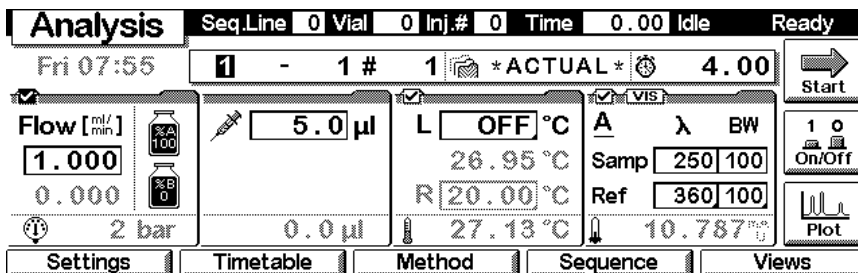

Control Module Screens for the Binary Pump
Screens available from the Analysis screen

Pump ON/OFF

From the Analysis screen use the F7 key to proceed to the turn on screen. Press F8 (**On**) once to turn on the pump. If more than one module is available, select the binary pump from the pop-up menu.

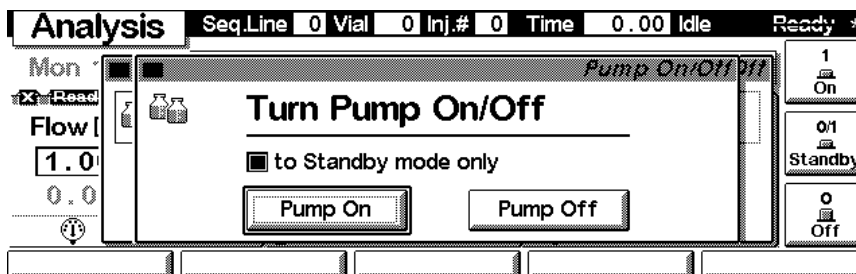
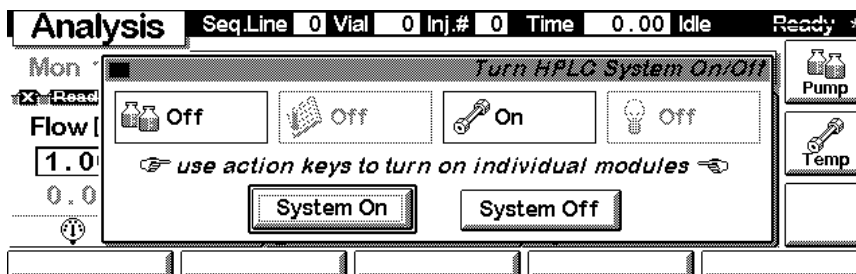

Settings

With the **Settings** key you open a pull-down menu where you can select the binary pump module.

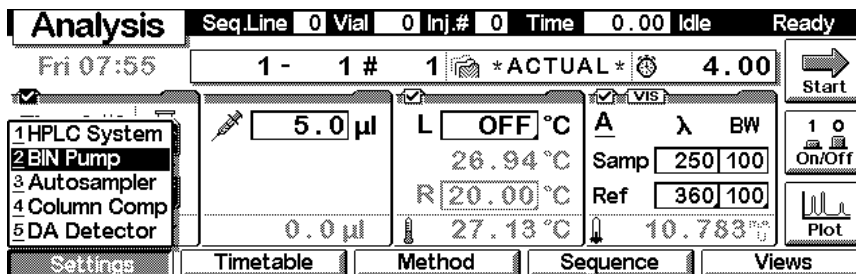

Settings

Within the **Settings** you can change the pump parameters. You have access to a different set of parameters available through the F1-5 keys. F7 key resets the pump to default values. F8 opens a window to turn on the pump.

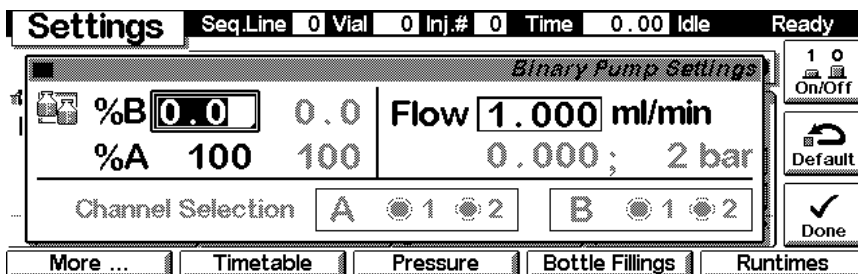

Use the **m**-key for the context sensitive menu. The **Status** command pulls up a monitor screen displaying signals and spectra as programmed. **Reset** will load the pump default parameters.

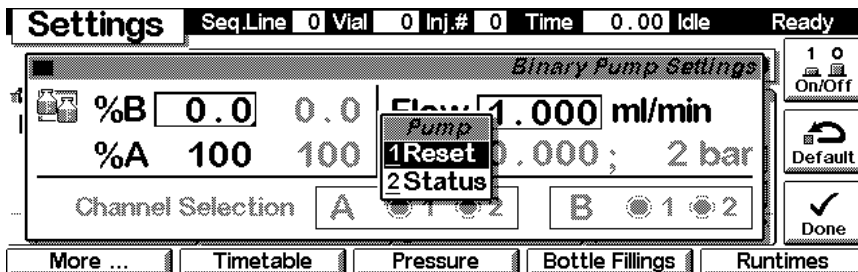

Use F1-key (**More**). You can enter special pump setpoints.

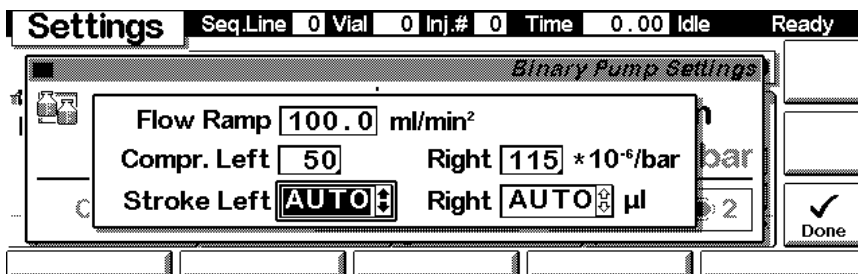

Control Module Screens for the Binary Pump
Screens available from the Analysis screen

Settings - Timetable

With the F2 key (**Timetable**) you can list the timetable for the pump. Press F7 key (**Insert**) to add entries or F6 key (**Delete**) to remove entries.

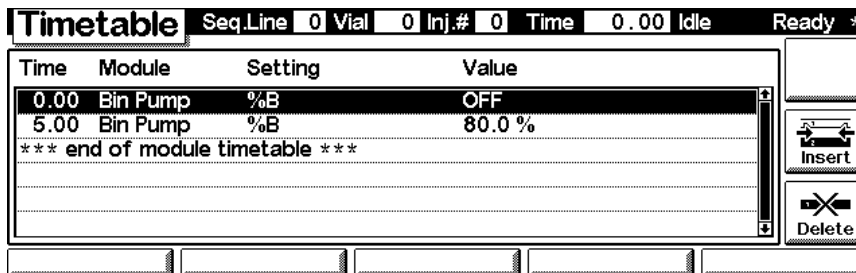

Use the F6 key (**Done**) to view the entered lines of the timetable.

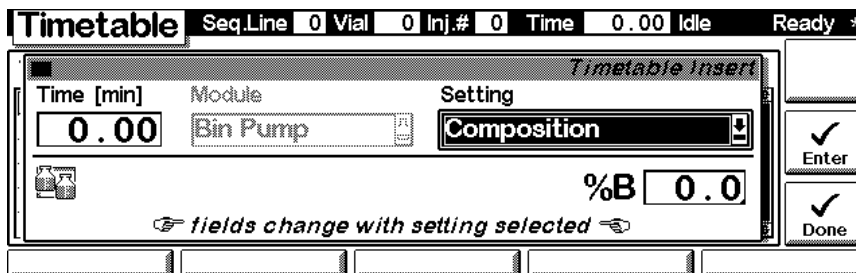

Use the **m**-key for the context sensitive menu. It gives you additional tools for the timetable.

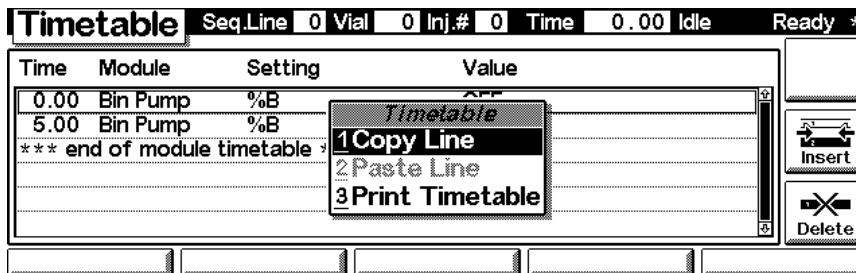

Control Module Screens for the Binary Pump
Screens available from the Analysis screen

Settings - Pressure

With the F3 key (**Pressure**) you can change the settings for the pressure limits.

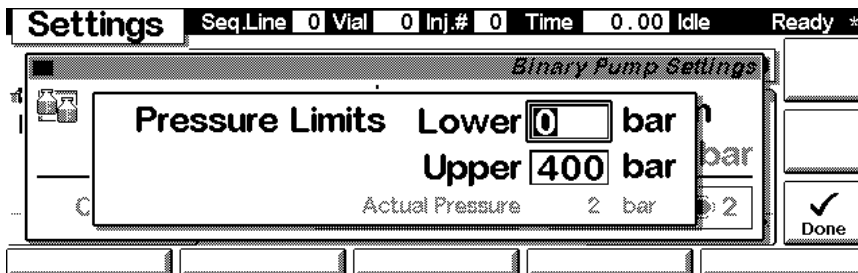

Settings - Bottle Fillings

With the F4 key (**Bottle Fillings**) you can adjust the settings for the bottle fillings to their current state.

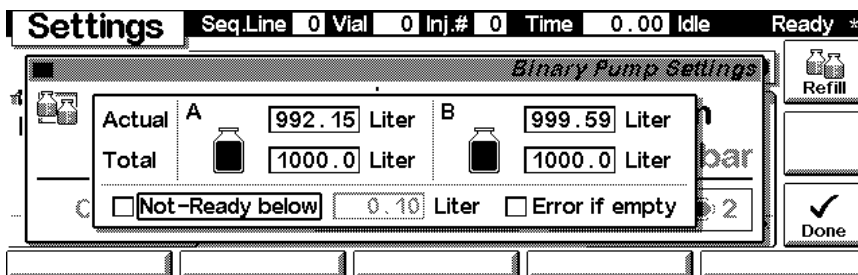

Settings - Runtimes

With the F5 key (**Runtimes**) you can change the stop time and the post-run time.

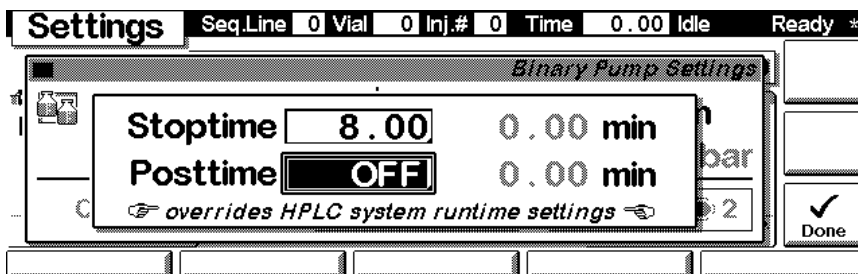

Control Module Screens for the Binary Pump
Screens available from the Analysis screen

Analog -Status

Press F5 key (**Views**) and select **Status**.

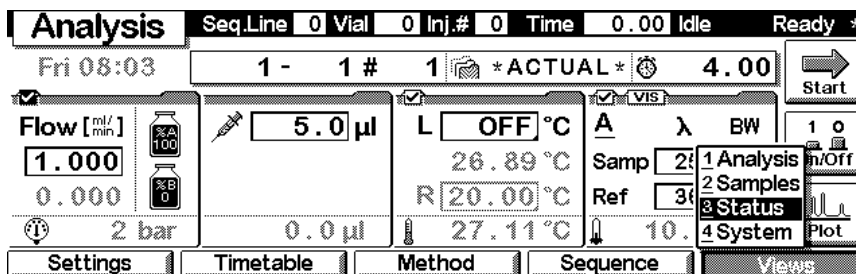

Status

This is an example if an Agilent 1100 pump is configured standalone. Information on the actual flow rate , mobile phase composition, pressure and %-ripple, elapsed run time and the pressure plot are shown. Press key F8 (**Start**) to start a run, key F7 (**Rescale**) to maximize the signal.

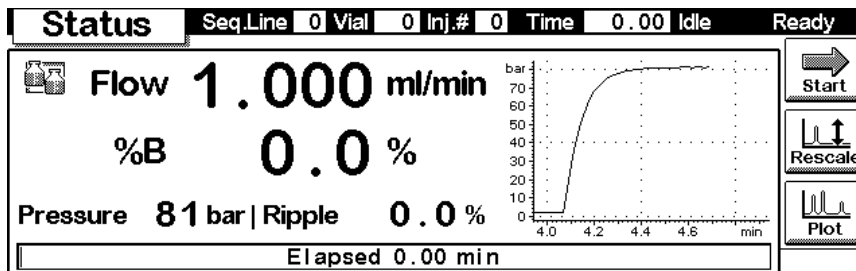

Signal plot

Press F6 key (**Plot**) to enter the plot screen (available also from the **Analysis** and **System** screen). Here you can observe the online signal(s). To add additional online signals (maximum 3), press F6 key (**Select**). If more than one signal is configured, use the 1-2-3 numeric keys to switch between the signals.

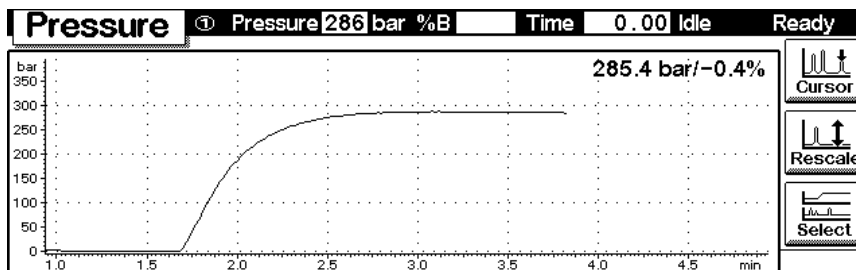

Screens available from the Analysis screen

Press F6 key (**Select**). Here you can add additional online signals (maximum are 3). Additional signals could also be chromatograms or temperature signals from other modules. Use the Right/Left arrows to switch between Available and Selected Signals. Use the F8 key (**Move**) to enter available signals into the box for selected signals or vice versa. Press **Done** to activate the changed settings and to return to the **Plot** screen.

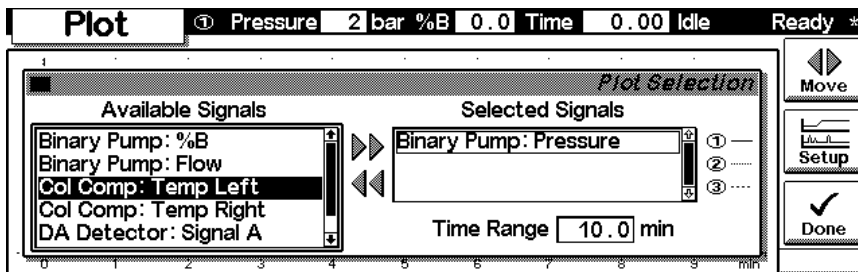

Method screens

On the **Analysis** screen use the F3 key (**Method**) to view the parameters in a method and F8 key (**Save As**) to save the method in the module(s). The PC-Card key is only active when a PCMCIA card is inserted in the control module (has to be inserted even before powercycling).

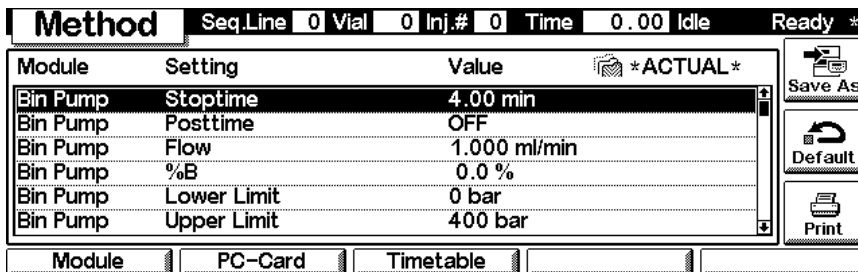

Screens available from the Analysis screen

Use F2 key (**PC-Card**) to save a method on a PCMCIA card. Use the Right/Left arrows to switch between PC-Card and Instrument window. Use the UP/Down arrows to select the method. Use the F7/F8 keys (**Copy**) to enter available signals into the box for selected signals or vice versa.

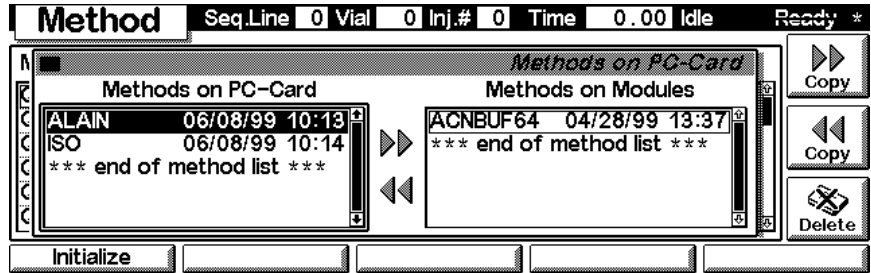

Screens available from the System screen

System screen

Use the Esc key to receive **Views** on the F5 key. Choose **System** from the pull-down menu. This screen shows the last activities in the system.

The screenshot shows the 'System' screen with the following data:

Module	Message	Id	Date	Time
Bin Pump	Timetable changed	INFO	09/24	07:59:24
Bin Pump	Timetable changed	INFO	09/24	07:59:19
Bin Pump	Timetable changed	INFO	09/24	07:58:55
Col Comp	Calibration done	STATE	09/24	07:52:04
DA Detector	VIS lamp on	STATE	09/24	07:52:00

Additional elements on the screen include: a status bar at the top with 'System', 'Pump' (unchecked), 'Temp' (checked), 'Lamp' (checked), 'Time 0.00', 'Idle', and 'Ready *'; a clock showing 'Fri 08:06'; a 'Start' button with a right arrow; an 'On/Off' button with a power icon; a 'Plot' button with a waveform icon; and a bottom navigation bar with buttons for 'Control', 'Configure', 'Tests', 'Records', and 'Views'.

System - Control

Use the F1 key (**Control**) to select the binary pump. Here you receive information about the not-ready conditions if needed. F2 key (**Reset**) does a re-initialization of the pump.

The screenshot shows the 'System - Control' screen with the following data:

Module	Message	Id	Date	Time
1 HPLC System	Timetable changed	INFO	09/24	07:59:24
2 BIN Pump	Timetable changed	INFO	09/24	07:59:19
3 Autosampler	Timetable changed	INFO	09/24	07:58:55
4 Column Comp	Calibration done	STATE	09/24	07:52:04
5 DA Detector	VIS lamp on	STATE	09/24	07:52:00

Additional elements on the screen include: a status bar at the top with 'System', 'Pump' (unchecked), 'Temp' (checked), 'Lamp' (checked), 'Time 0.00', 'Idle', and 'Ready *'; a clock showing 'Fri 08:07'; a 'Start' button with a right arrow; an 'On/Off' button with a power icon; a 'Plot' button with a waveform icon; and a bottom navigation bar with buttons for 'Control', 'Configure', 'Tests', 'Records', and 'Views'. The 'Control' button is highlighted.

Control Module Screens for the Binary Pump
Screens available from the System screen

**System -
Configuration**

On the **System** screen use the F2 key (**Configure**) to select the pump. Use the F1 key (**Interfaces**) to access the interface settings (if required).

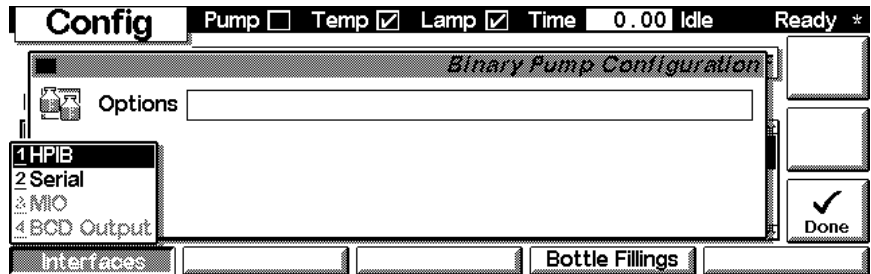

Press F4 (**Bottle fillings**) to adjust bottle fillings to the current state.

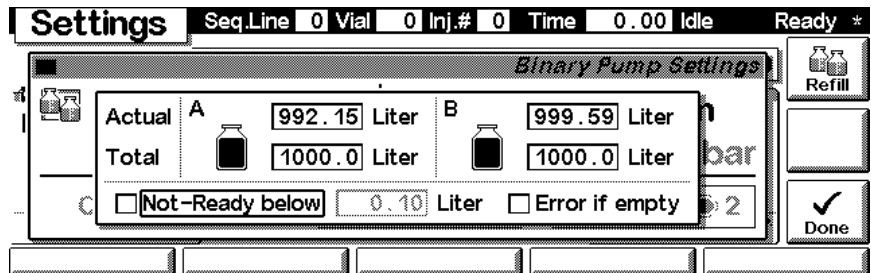

Screens available from the Records screen

Records screen

Use the Esc key to receive **Views** on the F5 key. Choose **System** from the pull-down menu. Use the F4 key (**Records**) to select the pump. Errors are reported either into the **System Log** (F2) or **Error Log** (F3).

Records						Pump <input type="checkbox"/>	Temp <input checked="" type="checkbox"/>	Lamp <input checked="" type="checkbox"/>	Time	0.00	Idle	Ready *
Module	Product#	Serial#	Version	On-Time	EMF							
Controller	G1323A*	DE53304451	A.02.04	0d 00:17h								
Bin Pump	G1312A	DE53500550	A.03.50	17d 19:14h								
Autosampler	G1313A	DE82206874	A.03.61	17d 19:15h								
Col Comp	G1316A*	DE82206546	A.03.60	17d 15:50h								
DA Detector	G1315A	DE53500166	A.03.80	17d 15:53h								

EMF System Log Error Log Maint Log FW Update

System / Error Log

Use the F2 key (**System Log**) or F3 key (**Error Log**) to look for errors.

Records						Pump <input type="checkbox"/>	Temp <input checked="" type="checkbox"/>	Lamp <input checked="" type="checkbox"/>	Time	0.00	Idle	Ready *
Binary Pump System Logbook												
Message	Date	Time										
Pump standby	99/09/24	07:52:03										
Timetable changed	99/09/24	07:58:55										
Timetable changed	99/09/24	07:59:19										
Timetable changed	99/09/24	07:59:24										
*** end of logbook ***												

Print

Control Module Screens for the Binary Pump
Screens available from the Records screen

Info Log

Use the **m**-key to receive a pop-up menu, Select **Info Log**. A list of the last events are listed. For troubleshooting reasons they can be printed or saved to a file on the PCMCIA card (using the **m**-key for the context sensitive menu).

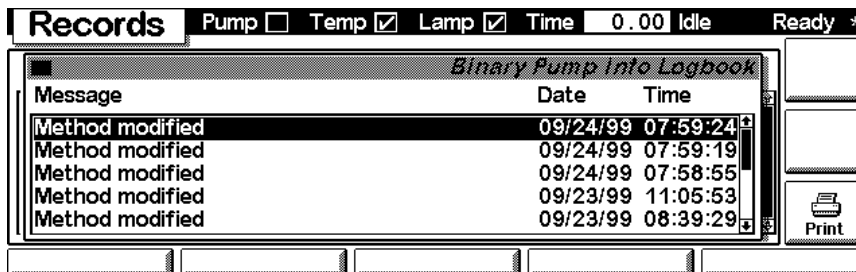

**EMF (Early
Maintenance
Feedback)**

Use the F1 key (**EMF**) to set EMF parameters. Choose menu item 1 (**Setup limits**) to select the amount of pumped solvent or seal wear, when you want to receive a warning for exceeded limits. Press F7 (**Reset**) to reset the counters after exchanging parts that are subject to wear.

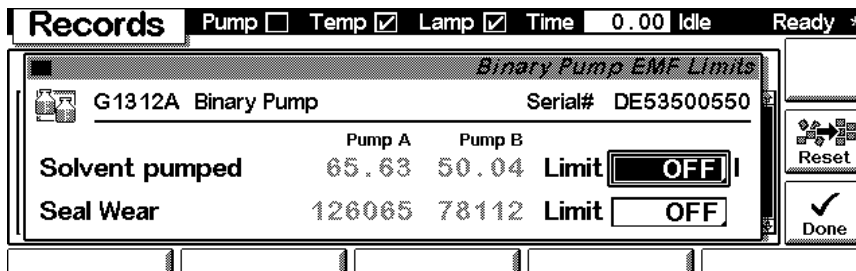

Screens available from the Records screen

If a set limit has been exceeded, a message box will pop up. This will not stop a sequence or run (information only to plan maintenance activities). If you press **Reset**, the limits will be removed. **Ignore** will continue to keep the EMF flag set.

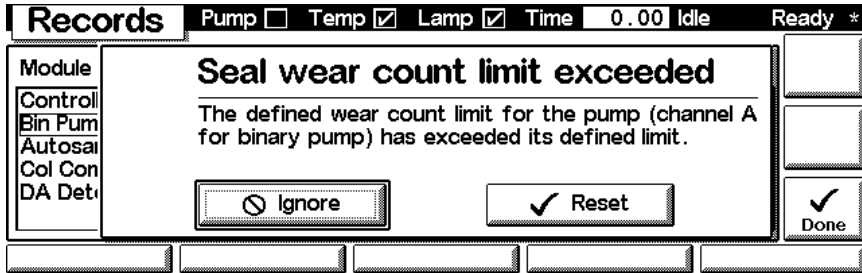

Firmware Update

Use the Esc key to receive **Views** on the F5 key. Choose **System** from the pull-down menu. Use the F3 key (**Records**) to select the pump. Use the F5 key (**FW Update**) to enter the Update section. If you want to update the resident firmware (together with specific main firmware revisions), select the file from the PCMCIA card (RESnmm.DLB) and press execute. If you want to update the main firmware, press F7 key (**Transfer**) to turn the module into the resident mode (LED on module should blink yellow).

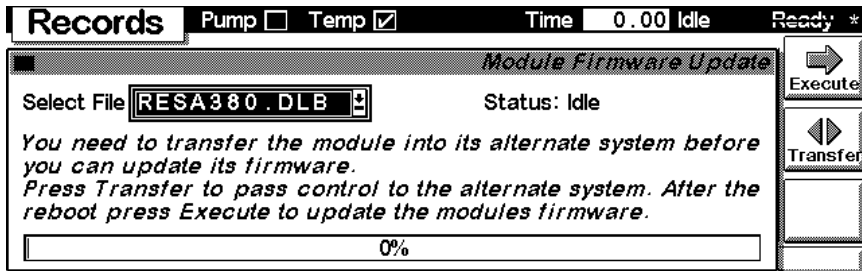

Control Module Screens for the Binary Pump
Screens available from the Records screen

Use the **Esc** key to receive **Views** on the F5 key. Choose **System** from the pull-down menu. Use the F3 key (**Records**) to select the **Generic** module. In this screen the resident firmware revision is shown.

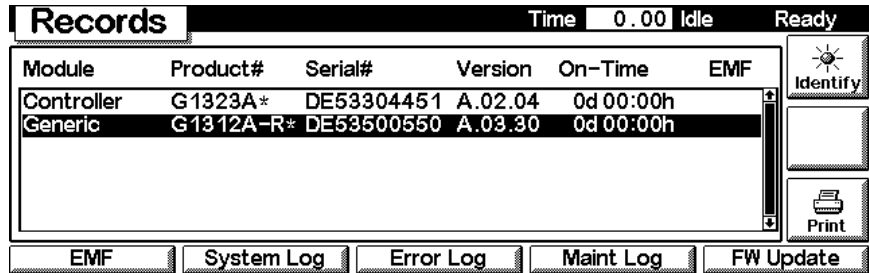

Use the F5 key (**FW Update**) to enter the Update section. Select the a file from the PCMCIA card (1312nnnn.DLB) and press execute. When the update has finished, press F7 key (**Transfer**) to return the module into the normal mode (LED on module should stay yellow).

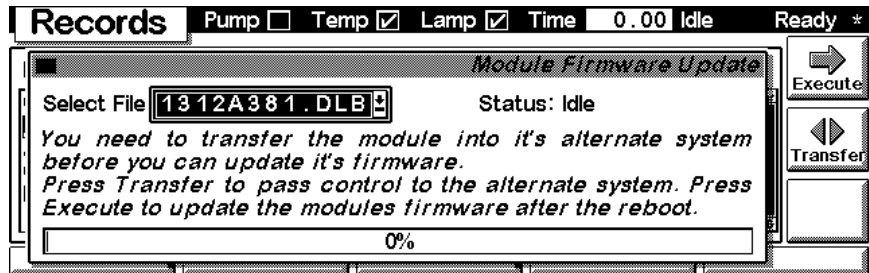

If you have not saved your methods, please do it before continuing. Otherwise they will be overwritten during the update process.

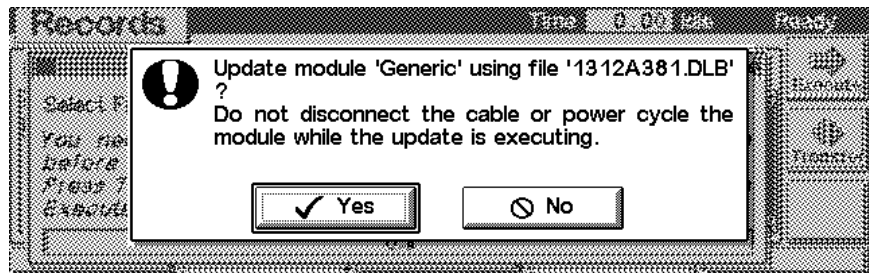

Control Module Screens for the Binary Pump
Screens available from the Records screen

Changing the serial number

In case the serial number of the module has to be added, use the **m**-key to open the menu **Enter Serial#**. The serial number becomes active after restart of the module.

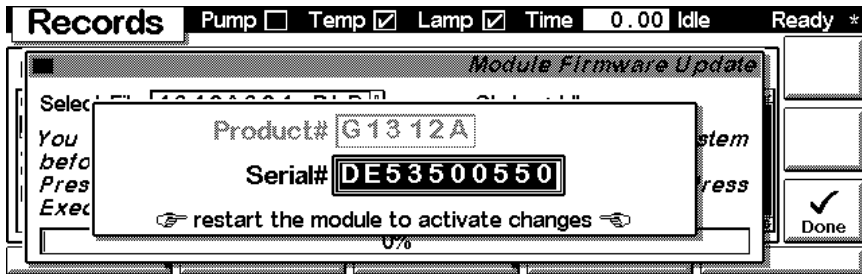
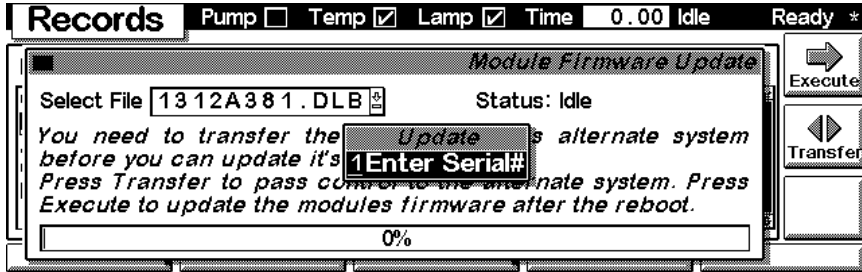

Maintenance activities

On the Records screen use the F4 key (**Maint log**) to view and edit the maintenance logbook.

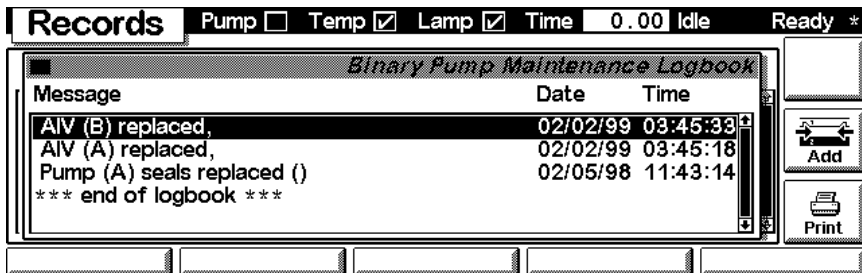

Control Module Screens for the Binary Pump
Screens available from the Records screen

Use the F7 key (**Add**) to add new maintenance activities. If an activity is not listed, you can type the activity into the line “Add” using the control modules key pad.

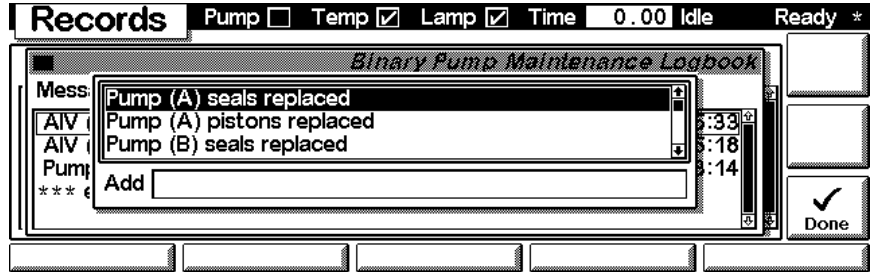

Diagnostics and Tests

Tests screen

Use the Esc key to receive **Views** on the F5 key. Choose **System** from the pull-down menu. Use the F3 key (**Tests**) to select the pump. Two tests are available to test the Agilent 1100 pumps.

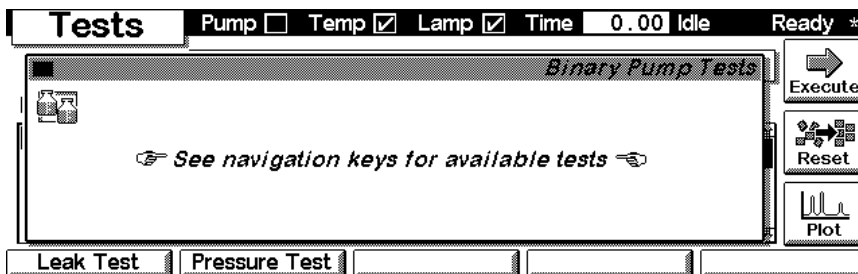

Leak Test

Press F1 (Leak Test) on the Test screen to perform a leak test. Several steps like purging the system, setting up Isopropanol as solvent on the channel that is supposed to be tested and blocking the purge valve outlet with a blank nut have to be performed before operating the leak test. For details use the 'i'-key to achieve context sensitive help, follow the instructions on the screen and refer to "Running the Leak Test" on page 94. For evaluating the leak test refer to "Evaluating the Results" on page 96.

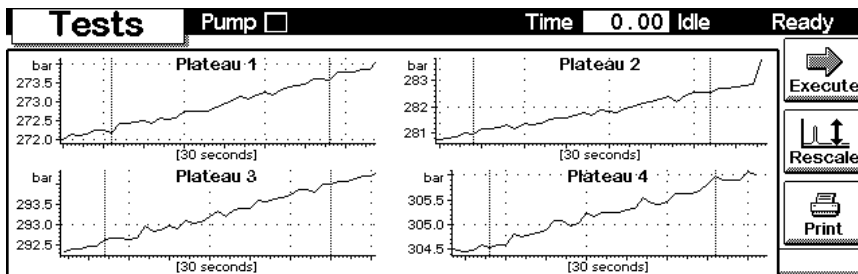

Diagnostics and Tests**Pressure Test**

Use the F2 key (**Pressure Test**) to perform a pressure test of the system. Several steps like purging the system, setting up Isopropanol as solvent on channel A or A2 (if solvent selection valve is installed) and blocking the column outlet with a blank nut have to be performed before operating the pressure test. For details use the 'i'-key to achieve context sensitive help, follow the instructions on the screen and refer to "Running the Pressure Test" on page 87. For evaluating the pressure test refer to "Evaluating the Results" on page 89.

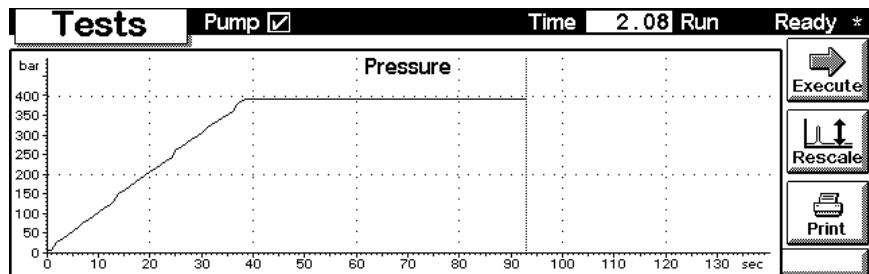

Specifications

Performance specifications of the binary pump

Specifications

Performance Specifications

Table 43

Performance Specification Agilent 1100 Series Binary Pump

Type	Specification
Hydraulic system	Two dual piston in series pumps with proprietary servo-controlled variable stroke drive, floating piston design and active inlet valve
Settable flow range	Setpoints 0.001 – 5 ml/min, in 0.001 ml/min increments
Flow range	0.1 – 5.0 ml/min
Flow precision	< 0.3 % RSD (typically 0.15 %), based on retention time, at 1 ml/min
Pressure	Operating range 0 400 bar (0 – 5880 psi) up to 5 ml/min
Pressure pulsation	< 2 % amplitude (typically < 1 %), at 1 ml/min isopropanol, at all pressures > 1 MPa
Compressibility compensation	User-selectable, based on mobile phase compressibility
Recommended pH range	1.0 – 12.5, solvents with pH < 2.3 should not contain acids which attack stainless steel
Gradient formation	High-pressure binary mixing, delay volume 180 – 480 µl without mixer, 600 – 900 µl with mixer, dependent on back pressure
Composition range	1 – 99 % or 5 µl/min per channel, whatever is greater
Composition precision	< 0.2 % SD, at 0.1 and 1 ml/min
Control and data evaluation	Agilent ChemStation for LC
Control and data evaluation	Agilent ChemStation for LC

Table 43

Performance Specification Agilent 1100 Series Binary Pump

Analog output	For pressure monitoring, 2 mV/bar, one output
Communications	Controller-area network (CAN), GPIB, RS-232C, APG Remote: ready, start, stop and shut-down signals, LAN optional
Safety and maintenance	Extensive diagnostics, error detection and display (through control module and Agilent ChemStation), leak detection, safe leak handling, leak output signal for shutdown of pumping system. Low voltages in major maintenance areas.
GLP features	Early maintenance feedback (EMF) for continuous tracking of instrument usage in terms of seal wear and volume of pumped mobile phase with user-settable limits and feedback messages. Electronic records of maintenance and errors.
Housing	All materials recyclable.

NOTE

For use with flow rates below 500 $\mu\text{l}/\text{min}$ a vacuum degasser is required.

Specifications

Performance Specifications

A

accessory kit, 18, 186
active inlet valve, 108, 109, 185
active inlet valve drive, 216
adapter, 28, 109
Agilent on internet, 276
air flow, 146
algae, 34, 37
alternative seal material, 41
ambient non-operating temperature, 16
ambient operating temperature, 16
analog cable, 188, 190
analog output, 210, 261
APG remote connector, 22, 227
ASIC - application-specific integrated circuit, 216
assembling the main cover, 159
AUTO mode, 209
AUX output, 22
auxiliary cable, 189, 199

B

ball-screw drive, 206
Batteries, 273
battery, 217, 273
baudrate setting, 232
BCD board, 131, 223
BCD cable, 188, 197
BCD output, 210
bench space, 15
binary pump checklist, 17
blank nut, 87, 94
block diagram, 218, 219
board connector, 136
board layout, 137
bottle head assembly, 17, 169
buffer application, 34
buffer solutions, 204

C

cable
 analog, 188, 190
 auxiliary, 189, 199
 BCD, 188, 197
 CAN, 18, 22, 199
 external contacts, 189, 200
 GPIB, 22, 189
 interface, 22

 overview, 188
 power, 17
 remote, 18, 188, 192
 signal, 18
CAN bus, 210
CAN cable, 22, 199
CAN interface, 226
capillary, pump to injection device, 18
changing solvents, 30
checklist, binary pump, 17
ChemStation, 22
cleaning the pump, 105
column, 204
compensation sensor open, 58
compensation sensor short, 59
compensation volume, 208
composition precision, 260
composition range, 260
compressibility compensation, 43, 260
condensation, 15
connections, flow, 24, 27
continuous seal wash, 40, 204
control module, 167
 EMF, 251
 firmware update, 252
 serial number change of MWD, 254
 tests, 256
cover parts, 174

D

damaged parts, 17
damper, 143
damping unit, 143, 207
data bit setting, 232
default addresses, 231
degreaser spray, 121
delay volume, 19, 42, 208
delivery checklist, 17
description, leak test, 92
design, 205
dimensions, 16
disassembling the pump head, 119
dual-piston in-series design, 205

E

early maintenance feedback (EMF), 212
electrical connections, 210

electronic fuses, 210, 217
electronics, HPM board, 215
electrostatic discharge (ESD), 104
EMF
 on control module, 251
EMF counter, 213
EMF flag, 213
EMF limits, 214
encoder missing, 75
environment, 14, 15
error
 zero solvent counter, 63
error condition, 49
error message
 wait timeout, 84
error messages, 46, 50
 compensation sensor open, 58
 compensation sensor short, 59
 encoder missing, 75
 fan failed, 60
 ignition without cover, 61
 index adjustment, 80
 index limit, 79
 index missing, 81
 initialization failed, 83
 inlet-valve fuse, 71
 inlet-valve missing, 76
 leak, 55
 leak sensor open, 56
 leak sensor short, 57
 missing pressure reading, 68
 motor-drive power, 74
 pressure above upper limit, 64
 pressure below lower limit, 65
 pump head missing, 78
 restart without cover, 62
 selection valve failed, 66
 selection-valve fuse, 70
 servo restart failed, 77
 shut-down, 52
 stroke length, 82
 synchronization lost, 53
 temperature limit exceeded, 73
 temperature out of range, 72
 timeout, 51
ESD Strap, 106
ESD wrist strap, 18
exchanging

-
- active inlet valve, 108, 109
damper, 143
fan, 145
high pressure pump main board (HPM board), 136
interface board, 131
internal parts, 104, 132
leak sensor, 156
outlet ball valve, 108, 112
outlet ball valve sieve, 108, 112
pistons, 108, 124
power supply, 151
pump drive, 148
pump seals, 108, 121
purge valve, 108, 114
purge valve frit, 108, 114
solvent selection valve, 117
status light pipe, 158
wash seals, 108, 125, 127
external contact cable, 189, 200
external contacts, 210
- F**
fan, 145
fan drive, 216
fan failed, 60
fan out, 227
fastest gradient response, 42
features
 GLP, 261
 instrument layout, 212
 safety and maintenance, 261
firmware
 description, 221
 main system, 221
 resident system, 221
 updates, 222
firmware update with control module, 252
flow cell
 solvent information, 275
flow connections, 24, 27
flow precision, 260
flow range, 260
foam, 133, 160
foam parts, 176
forced cold-start setting, 233
frequency range, 16, 210
- frit, 114
fuse, 210, 217
- G**
gas solubility, 34
GPIB
 Default Addresses, 231
GPIB cable, 22, 189
GPIB connector, 210
GPIB interface, 226
gradient formation, 260
- H**
hex key set, 18
hexagonal key, 3 mm, 119, 121, 124, 127, 129
hexagonal key, 4 mm, 119, 121, 124, 125, 127, 129, 148
high pressure pump main board (HPM), 216
high-pressure mixing, 204
hints for successful use, 34
HPM board, 136
humidity, 16
hydraulic path with solvent selection valve, 170
hydraulic path without solvent selection valve, 172
hydraulic system, 260
- I**
index adjustment, 80
index limit, 79
index missing, 81
indicator, power supply, 49
indicator, status, 48
initialization, 207
initialization failed, 83
injection precision, 39
inlet-valve fuse, 71
inlet-valve missing, 76
insert tool, 127
installation, pump module, 21
instrument status indicator, 49
interface
 CAN, 226
 GPIB, 226
 remote, 227
- RS-232C, 227
interface board, 131
interface cable, 22
interfaces, 217
internet, 276
introduction to the pump, 204
- L**
laboratory, 15
laboratory bench, 15
lamp, instrument status, 49
lamp, power supply, 49
lamp, status, 48
LAN cables, 202
LAN interface board, 224
leak, 55
leak converter, 216
leak parts, 178
leak sensor, 156
leak sensor open, 56
leak sensor short, 57
leak test, 46, 91
leak test, evaluation, 96
light pipes, 177
line frequency, 16, 210
line input, 236
line voltage, 16, 210
liquimeter, 122, 213
lithium battery, 273
logbook, 51
- M**
main assemblies, overview, 107
main cover, 159
main power supply assembly, 235
main power supply specification, 236
maintenance procedures, 213
message
 ignition without cover, 61
minimum flow rate, 34
missing parts, 17
missing pressure reading, 68
mixer, 205
motor drive, 216
motor-drive power, 74
- N**
non-operating altitude, 16
-

non-operating temperature, 16
not-ready condition, 49

O

onboard battery, 217
operating altitude, 16
operating temperature, 16
optimum performance, 19
outlet ball valve, 108, 112, 183
overview
 pump, 205

P

parity setting, 233
parts
 accessory kit, 186
 active inlet valve, 185
 bottle head assembly, 169
 control module, 167
 cover, 174
 damaged, 17
 foam, 176
 hydraulic path with solvent selection valve, 170
 hydraulic path without solvent selection valve, 172
 leak handling, 178
 light pipes, 177
 missing, 17
 outlet ball valve, 183
 pump head, 179
 pump head assembly with seal wash, 181
 pump housing and main assemblies, 165, 166
 purge valve, 184
 sheet metal kit, 175
 solvent cabinet, 168
parts identification
 cables - LAN cables, 202
performance specification, 260
pH range, 260
physical specification, 16
piston, 108, 124, 206
power consideration, 14
Power consumption, 16
power consumption, 16
power light pipe, 177

power supply, 151, 235
power supply indicator, 49
power supply specification, 236
power switch, 21
power-input socket, 14
precision, 34
prerun condition, 49
pressure above upper limit, 64
pressure below lower limit, 65
Pressure Converter, 216
pressure plot, leak test, 96
pressure pulsation, 43, 209, 260
pressure range, 41
pressure sensor readings, 22
pressure test, 46, 85
pressure, operating range, 260
priming
 with a pump, 30, 31, 39
 with a syringe, 30, 39
PTFE frit, 18, 108, 114, 184
PTFE lubricant, 129
pump head assembly, 179
pump head assembly with seal wash, 181
pump head missing, 78
pump seals, 34, 108, 121
purge valve, 34, 108, 114, 184
purge-valve assembly, 207
purging the pump, 30

R

radio interference, 274
reassembling the pump head, 129
recommended pH range, 260
remote
 signal distribution, 228
remote cable, 188, 192
remote connector, 210
remote interface, 227
removing the foam, 133
removing the pump head, 119
removing the top cover, 133
repair procedures, 108
replacing the foam, 160
replacing the top cover, 160
reproducibility, 34
restart without cover, 62
results, pressure test, 89

RS-232

 cable kit to PC, 201
RS-232C communication setting, 231
RS-232C connection table, 229
RS-232C connector, 210
RS-232C interface, 227
run mode, 49
running the leak test, 94
running the pressure test, 87

S

safety
 standards, 16
safety light switch, 160
sapphire piston, 206
screwdriver pozidriv #1, 117, 143, 145, 148, 151, 156, 158, 160
screwdriver, flat-head, 127
seal insert tool, 18
seal wash, 40, 205
seal wear counter, 122, 213
seal, alternative material, 41
seals, 34, 108
security lever, 21, 104
selection valve failed, 66
selection-valve fuse, 70
serial number
 entered on control module, 254
serial number change with control module, 254
servo restart failed, 77
setable flow range, 260
setting
 baudrate, 232
 data bit, 232
 forced cold-start, 233
 parity, 233
 RS-232C communication, 231
 stay resident, 233
sheet metal kit, 175
shipping container, 17
shut-down, 52
sieve, 108, 112, 183
simple repair procedures, 108
site requirements, 14
snap fastener, 24, 27
solvent bottle, 17
solvent cabinet, 17, 24, 34, 168

solvent filters
 checking, 37
 cleaning, 38
solvent information, 36, 275
solvent inlet filter, 34
solvent selection valve, 24, 204
solvent selection valve drive, 216
solvents, 275
solvents filters
 prevent blocking, 37
sonic bath, 112
sound emission, 274
solvent selection valve, 117
specification
 main power supply, 236
 performance, 260
 physical, 16
spectrum
 range, 244
stack configuration, 19
stack configuration, front view, 19
stack configuration, rear view, 20
static mixer, 42
status indicators, 46, 48
status light pipe, 158, 177
stay resident settings, 233
stroke length, 82
stroke volume, 206, 209
synchronization lost, 53
syringe adapter, 30

T

temperature limit exceeded, 73
temperature out of range, 72
tests on control module, 256
timeout, 51
top cover, 133, 160
tweezers, 114

U

unpacking the pump, 17

V

vacuum degasser, 34, 204, 261
vacuum degasser, operational hints, 39
vacuum degasser, when to use, 39
variable reluctance motor, 206
variable stroke volume, 209

velocity regulator, 18, 40
voltage range, 16, 210, 236
voltage selector, 210

W

wait timeout, 84
wall socket, 14
warranty
 responsibility of Agilent Technologies, 269
 services, 269
wash seals, 108, 127
waste tube, 18
weight, 16
wideranging capability, 14
wrench 1/4 inch, 87, 94, 112, 114, 119, 143, 145, 148, 151, 156
wrench 14 mm, 109, 112, 114, 136, 151, 156
wrench 5 mm, 136, 151, 156
wrench 7 mm, 136, 151, 156
wrench, 1/4 - 5/16 inch, 18
wrench, 14 mm, 18

Z

zero solvent counter, 63

Warranty Statement

All Chemical Analysis Products

Agilent Technologies warrants its chemical analysis products against defects in materials and workmanship. For details of the warranty period in your country, call Agilent. During the warranty period, Agilent will, at its option, repair or replace products which prove to be defective. Products that are installed by Agilent are warranted from the installation date, all others from the ship date.

If buyer schedules or delays installation more than 30 days after delivery, then warranty period starts on 31st day from date of shipment (60 and 61 days, respectively for products shipped internationally).

Agilent warrants that its software and firmware designed by Agilent for use with a CPU will execute its programming instructions when properly installed on that CPU. Agilent does not warrant that the operation of the CPU, or software, or firmware will be uninterrupted or error-free.

Limitation of Warranty

Onsite warranty services are provided at the initial installation point. Installation and onsite warranty services are available only in Agilent service travel areas, and only in the country of initial purchase unless buyer pays Agilent international prices for the product and services. Warranties requiring return to Agilent are not limited to the country of purchase.

For installation and warranty services outside of Agilent's service travel area, Agilent will provide a quotation for the applicable additional services.

If products eligible for installation and onsite warranty services are moved from the initial installation point, the warranty will remain in effect only if the customer purchases additional inspection or installation services, at the new site.

The foregoing warranty shall not apply to defects resulting from:

- 1 improper or inadequate maintenance, adjustment, calibration, or operation by buyer,
- 2 buyer-supplied software, hardware, interfacing or consumables,
- 3 unauthorized modification or misuse,

Warranty Statement

- 4 operation outside of the environmental and electrical specifications for the product,
- 5 improper site preparation and maintenance, or
- 6 customer induced contamination or leaks.

THE WARRANTY SET FORTH IS EXCLUSIVE AND NO OTHER WARRANTY, WHETHER WRITTEN OR ORAL, IS EXPRESSED OR IMPLIED. AGILENT SPECIFICALLY DISCLAIMS THE IMPLIED WARRANTIES OF MERCHANTABILITY AND FITNESS FOR A PARTICULAR PURPOSE.

Limitation of Remedies and Liability

THE REMEDIES PROVIDED HEREIN ARE BUYER'S SOLE AND EXCLUSIVE REMEDIES. IN NO EVENT SHALL AGILENT BE LIABLE FOR DIRECT, INDIRECT, SPECIAL, INCIDENTAL, OR CONSEQUENTIAL DAMAGES (INCLUDING LOSS OF PROFITS) WHETHER BASED ON CONTRACT, TORT OR ANY OTHER LEGAL THEORY.

Responsibilities of the Customer

The customer shall provide:

- 1 access to the products during the specified periods of coverage to perform maintenance,
- 2 adequate working space around the products for servicing by Agilent personnel,
- 3 access to and use of all information and facilities determined necessary by Agilent to service and/or maintain the products (insofar as these items may contain proprietary or classified information, the customer shall assume full responsibility for safeguarding and protection from wrongful use),
- 4 routine operator maintenance and cleaning as specified in the Agilent operating and service manuals, and
- 5 consumables such as paper, disks, magnetic tapes, ribbons, inks, pens, gases, solvents, columns, syringes, lamps, septa, needles, filters, frits, fuses, seals, detector flow cell windows, and so on.

Responsibilities of Agilent Technologies

Agilent Technologies will provide warranty services as described in Table 44.

Table 44

Warranty Services

Services During Warranty *	Warranty Period **	Type
Agilent 1100 Series of Modules	1 Year	Onsite
GC, LC, UV-Visible, and LAS supplies and accessories	90 Days	Onsite
Columns and Consumables ***	90 Days	Return to Agilent
Gas Discharge and Tungsten Lamps	30 Days	Return to Agilent
Repairs performed on-site by Agilent ****	90 Days	Onsite

* This warranty may be modified in accordance with the law of your country. Please consult your local Agilent office for the period of the warranty, for shipping instructions and for the applicable wording of the local warranty.

** Warranty services are included as specified for Analytical products and options purchased concurrently provided customer is located within a Agilent defined travel area. Agilent warranty service provides for 8 a.m. to 5 p.m. on-site coverage Monday through Friday, exclusive of Agilent holidays.

*** Columns and Consumables are warranted to be free from defects for a period of 90 days after shipment and will be replaced on a return-to-Agilent basis if unused.

**** Agilent repair warranty is limited to only the item repaired or replaced.

Safety Information

The following general safety precautions must be observed during all phases of operation, service, and repair of this instrument. Failure to comply with these precautions or with specific warnings elsewhere in this manual violates safety standards of design, manufacture, and intended use of the instrument. Agilent Technologies assumes no liability for the customer's failure to comply with these requirements.

General

This is a Safety Class I instrument (provided with terminal for protective earthing) and has been manufactured and tested according to international safety standards.

Operation

Before applying power, comply with the installation section. Additionally the following must be observed.

Do not remove instrument covers when operating. Before the instrument is switched on, all protective earth terminals, extension cords, auto-transformers, and devices connected to it must be connected to a protective earth via a ground socket. Any interruption of the protective earth grounding will cause a potential shock hazard that could result in serious personal injury. Whenever it is likely that the protection has been impaired, the instrument must be made inoperative and be secured against any intended operation.

Make sure that only fuses with the required rated current and of the specified type (normal blow, time delay, and so on) are used for replacement. The use of repaired fuses and the short-circuiting of fuseholders must be avoided.

Some adjustments described in the manual, are made with power supplied to the instrument, and protective covers removed. Energy available at many points may, if contacted, result in personal injury.

Any adjustment, maintenance, and repair of the opened instrument under voltage should be avoided as much as possible. When inevitable, this should be carried out by a skilled person who is aware of the hazard involved. Do not attempt internal service or adjustment unless another person, capable of

Safety Information

rendering first aid and resuscitation, is present. Do not replace components with power cable connected.

Do not operate the instrument in the presence of flammable gases or fumes. Operation of any electrical instrument in such an environment constitutes a definite safety hazard.

Do not install substitute parts or make any unauthorized modification to the instrument.

Capacitors inside the instrument may still be charged, even though the instrument has been disconnected from its source of supply. Dangerous voltages, capable of causing serious personal injury, are present in this instrument. Use extreme caution when handling, testing and adjusting.



When working with solvents please observe appropriate safety procedures (e.g. goggles, safety gloves and protective clothing) as described in the material handling and safety data sheet by the solvent vendor, especially when toxic or hazardous solvents are used.

Safety Symbols

Table 45 shows safety symbols used on the instrument and in the manuals.

Table 45

Safety Symbols

Symbol	Description
	The apparatus is marked with this symbol when the user should refer to the instruction manual in order to protect the apparatus against damage.
	Indicates dangerous voltages.
	Indicates a protected ground terminal.

WARNING

A warning alerts you to situations that could cause physical injury or damage to the equipment. Do not proceed beyond a warning until you have fully understood and met the indicated conditions.

Safety Information

CAUTION

A caution alerts you to situations that could cause a possible loss of data. Do not proceed beyond a caution until you have fully understood and met the indicated conditions.

Lithium Batteries Information

WARNING

Danger of explosion if battery is incorrectly replaced. Replace only with the same or equivalent type recommended by the equipment manufacturer. Lithium batteries may not be disposed-off into the domestic waste.

Transportation of discharged Lithium batteries through carriers regulated by IATA/ICAO, ADR, RID, IMDG is not allowed. Discharged Lithium batteries shall be disposed off locally according to national waste disposal regulations for batteries.

ADVARSEL

Lithiumbatteri - Eksplosionsfare ved fejlagtig håndtering. Udskiftning må kun ske med batteri af samme fabrikat og type. Lever det brugte batteri tilbage til leverandoren.

ADVARSEL

Lithiumbatteri - Eksplosionsfare. Ved udskiftning benyttes kun batteri som anbefalt av apparatfabrikanten. Brukt batteri returneres apparatleverandoren.

NOTE

Bij dit apparaat zijn batterijen geleverd. Wanneer deze leeg zijn, moet u ze niet weggooien maar inleveren als KCA.

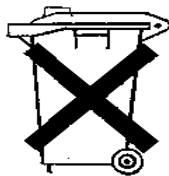

Radio Interference

Never use cables other than the ones supplied by Agilent Technologies to ensure proper functionality and compliance with safety or EMC regulations.

Test and Measurement

If test and measurement equipment is operated with equipment unshielded cables and/or used for measurements on open set-ups, the user has to assure that under operating conditions the radio interference limits are still met within the premises.

Sound Emission

Manufacturer's Declaration

This statement is provided to comply with the requirements of the German Sound Emission Directive of 18 January 1991.

This product has a sound pressure emission (at the operator position) < 70 dB.

- Sound Pressure $L_p < 70$ dB (A)
- At Operator Position
- Normal Operation
- According to ISO 7779:1988/EN 27779/1991 (Type Test)

Solvent Information

Observe the following recommendations on the use of solvents.

Flow Cell

Avoid the use of alkaline solutions (pH > 11) which can attack quartz and thus impair the optical properties of the flow cell.

Solvents

Always filter solvents through 0.4 µm filters, small particles can permanently block the capillaries and valves. Avoid the use of the following steel-corrosive solvents:

- Solutions of alkali halides and their respective acids (for example, lithium iodide, potassium chloride, and so on).
- High concentrations of inorganic acids like sulfuric acid and nitric acid, especially at higher temperatures (replace, if your chromatography method allows, by phosphoric acid or phosphate buffer which are less corrosive against stainless steel).
- Halogenated solvents or mixtures which form radicals and/or acids, for example:
$$2\text{CHCl}_3 + \text{O}_2 \rightarrow 2\text{COCl}_2 + 2\text{HCl}$$

This reaction, in which stainless steel probably acts as a catalyst, occurs quickly with dried chloroform if the drying process removes the stabilizing alcohol.
- Chromatographic grade ethers, which can contain peroxides (for example, THF, dioxane, di-isopropylether) such ethers should be filtered through dry aluminium oxide which adsorbs the peroxides.
- Solvents containing strong complexing agents (e.g. EDTA).
- Mixtures of carbon tetrachloride with 2-propanol or THF.

Agilent Technologies on Internet

For the latest information on products and services visit our worldwide web site on the Internet at:

<http://www.agilent.com/go/chem>

Select “Products” - “Chemical Analysis”

It will also provide the latest firmware of the Agilent 1100 series modules for download.



Agilent Technologies

Innovating the HP Way

In This Book

This manual contains technical reference information about the Agilent 1100 Series binary pump. The manual describes the following:

- installation,
- optimizing performance,
- diagnostics and troubleshooting,
- repairing,
- parts and materials,
- introduction to the pump, theory of operation,
- screens of the local control module and
- specifications.



G1312-90003