



Symbol Symbol Symbole Símbolo	Simbolo 記号 符号 Title / Titel / Titre / Titolo / Titolo / 名称 / 名称
	Dangerous voltage Gefährliche elektrische Spannung Courant haute tension Voltaje peligroso Pericolo: alta tensione 危険電圧 危险电压
	Attention, consult accompanying documents Achtung! Begleitpapiere beachten! Attention, consulter les documents joints Atención, consulte los documentos adjuntos Attenzione: consultare le informazioni allegate 注意、添付資料を参照のこと 注意，请参阅附带的文件
	On (power) Ein (Netzverbindung) Marche (mise sous tension) Encendido Acceso (sotto tensione) 入（電源） 开（电源）
	Off (power) Aus (Netzverbindung) Arrêt (mise hors tension) Apagado Spento (fuori tensione) 切（電源） 关（电源）
	Protective earth (ground) Schutzleiteranschluß Liaison à la terre Puesta a tierra de protección Collegamento di protezione a terra 保護アース（接地） 保护接地
	Earth (ground) Erde Terre Tierra Scarica a terra アース（接地） 接地



SAFETY NOTICE

This safety notice summarizes information basic to the safe operation of the equipment described in this manual. The international symbol displayed above is a reminder that all safety instructions should be read and understood before installation, operation, maintenance, or repair of this centrifuge. When you see the symbol on other pages, pay special attention to the safety information presented. Observance of safety precautions will also help to avoid actions that could damage or adversely affect the performance of the centrifuge.

Safety During Installation and/or Maintenance

This centrifuge weighs 41.0 kg (90.4 lb). DO NOT attempt to lift or move it without assistance from another person.

Any servicing of this equipment that requires removal of any covers can expose parts which involve the risk of electric shock or personal injury. Make sure that the power switch is off and the centrifuge is disconnected from the main power source, and refer such servicing to qualified personnel.

Do not replace any centrifuge components with parts not specified for use on this instrument.

Electrical Safety

To reduce the risk of electrical shock, this equipment uses a three-wire electrical cord and plug to connect the centrifuge to earth-ground. To preserve this safety feature:

- Make sure that the matching wall outlet receptacle is properly wired and earth-grounded. Check that the line voltage agrees with the voltage listed on the name-rating plate affixed to the centrifuge.
- Never use a three-to-two wire plug adapter.
- Never use a two-wire extension cord or a two-wire non-grounding type of multiple-outlet receptacle strip.

Do not place containers holding liquid on or near the chamber door. If they spill, liquid may get into the centrifuge and damage electrical or mechanical components.

Safety Against Risk of Fire

Certain electrical circuits within this equipment are protected by fuses against overcurrent conditions. For continued protection against the risk of fire, replace only with the same type and rating specified.

This centrifuge is not designed for use with materials capable of developing flammable or explosive vapors. Do not centrifuge such materials (such as chloroform or ethyl alcohol) in this centrifuge nor handle or store them within the 30-cm (1-ft) area surrounding the centrifuge.

Mechanical Safety

For safe operation of the equipment, observe the following:

- Use only the rotors and accessories designed for use in this centrifuge.
- Before starting the centrifuge, make sure that the rotor lid is properly installed and the tie-down screw is securely fastened.
- Do not exceed the maximum rated speed of the rotor in use.
- NEVER attempt to slow or stop the rotor by hand.
- Do not lift or move the centrifuge while the rotor is spinning.
- NEVER attempt to override the door interlock system while the rotor is spinning.
- Maintain a 7.6-cm (3-in.) clearance envelope around the centrifuge while it is running. During operation come within the envelope only to adjust instrument controls, if necessary. Never lean on the centrifuge or place items on the centrifuge while it is operating.

Chemical and Biological Safety

Normal operation may involve the use of solutions and test samples that are pathogenic, toxic, or radioactive. Such materials should not be used in this centrifuge, however, unless all necessary safety precautions are taken.

- Observe all cautionary information printed on the original solution containers prior to their use.
- Handle body fluids with care because they can transmit disease. No known test offers complete assurance that they are free of micro-organisms. Some of the most virulent—Hepatitis (B and C) and HIV (I–V) viruses, atypical mycobacteria, and certain systemic fungi—further emphasize the need for aerosol protection. Handle other infectious samples according to good laboratory procedures and methods to prevent spread of disease. Because spills may generate aerosols, observe proper safety precautions for aerosol containment. Do not run toxic, pathogenic, or radioactive materials in this centrifuge without taking appropriate safety precautions. Biosafe containment should be used when Risk Group II materials (as identified in the World Health Organization Laboratory Biosafety Manual) are handled; materials of a higher group require more than one level of protection.
- Dispose of all waste solutions according to appropriate environmental health and safety guidelines.

It is your responsibility to decontaminate the centrifuge and accessories before requesting service by a Beckman Coulter representative.

RoHS Notice

These labels and materials declaration table (the Table of Hazardous Substance's Name and Concentration) are to meet People's Republic of China Electronic Industry Standard SJ/T11364-2006 "Marking for Control of Pollution Caused by Electronic Information Products" requirements.



China RoHS Caution Label — This label indicates that the electronic information product contains certain toxic or hazardous substances. The center number is the Environmentally Friendly Use Period (EFUP) date, and indicates the number of calendar years the product can be in operation. Upon the expiration of the EFUP, the product must be immediately recycled. The circling arrows indicate the product is recyclable. The date code on the label or product indicates the date of manufacture.



China RoHS Environmental Label — This label indicates that the electronic information product does not contain any toxic or hazardous substances. The center "e" indicates the product is environmentally safe and does not have an Environmentally Friendly Use Period (EFUP) date. Therefore, it can safely be used indefinitely. The circling arrows indicate the product is recyclable. The date code on the label or product indicates the date of manufacture.

Microfuge 22R Centrifuge

Instruction Manual

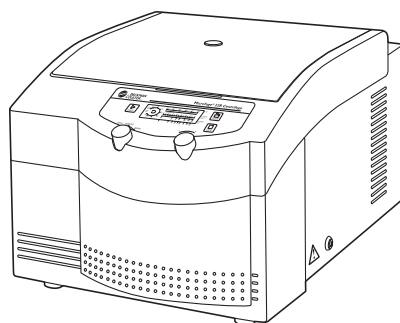

	Page
INTRODUCTION	
<i>Certification</i>	vii
<i>Scope of Manual</i>	vii
<i>Conventions</i>	viii
<i>Notes, Cautions, and Warnings</i>	viii
<i>CFC-Free Centrifugation</i>	ix
<i>Radio Interference</i>	ix
<i>Recycling Label</i>	x
SECTION 1: DESCRIPTION	
Centrifuge Function, Specifications, and Safety Features	1-1
Centrifuge Functions	1-1
Specifications	1-2
Available Rotors	1-3
Safety Features	1-4
Ground Wire Check	1-4
Name Rating Plate	1-4
Chassis	1-5
Housing	1-5
Door	1-5
Rotor Chamber	1-5
Drive	1-5
Temperature Sensing and Control	1-6

	Page
Controls and Indicators	1-6
Power Switch	1-6
Control Panel	1-6
SECTION 2: INSTALLATION	
Installing the Centrifuge	2-1
Transportation Safety Devices	2-3
Electrical Requirements	2-3
Test Run	2-4
SECTION 3: OPERATION	
Preparation and Loading	3-2
Starting a Timed or Hold Run	3-4
Starting a Pulse Run	3-6
Pulse Mode 1	3-6
Pulse Mode 2	3-7
Unloading	3-8
SECTION 4: TROUBLESHOOTING	
Troubleshooting	4-1
Error Messages	4-2
Accessing the Rotor in Case of Power Failure	4-3
SECTION 5: CARE AND MAINTENANCE	
Maintenance	5-2
Preventive Maintenance	5-2
Replacing Fuses	5-2
Cleaning	5-4
Decontamination	5-4

	Page
Sterilization and Disinfection	5-5
Storage and Transport	5-5
Storage	5-5
Transport	5-5
Returning a Centrifuge	5-6
Supply List	5-7
Replacement Parts	5-7
Supplies	5-7

Warranty

Illustrations and Tables

	Page
Figure 1-1. The Microfuge 22R Centrifuge	1-2
Figure 1-2. The Control Panel.	1-7
Figure 2-1. Dimensions of the Microfuge 22R Centrifuge.	2-2
Table 4-1. Troubleshooting Chart	4-2
Table 4-2. Error Message Chart.	4-3

CERTIFICATION

To ensure full system quality, Beckman Coulter Microfuge 22R centrifuges are manufactured in an ISO 9001 or 13485 facility. They have been designed and tested to be compliant (when used with Beckman Coulter rotors) with the laboratory equipment requirements of applicable regulatory agencies. Declarations of conformity and certificates of compliance are available at www.beckmancoulter.com.

SCOPE OF MANUAL

This manual is designed to familiarize you with the Beckman Coulter Microfuge 22R centrifuge, its functions, specifications, operation, and routine operator care and maintenance. We recommend that you read this entire manual, especially the SAFETY NOTICE and all safety-related information, before operating the centrifuge or performing instrument maintenance.

- Section 1 contains system specifications and a brief physical and functional description of the centrifuge, including the operating controls and indicators.
- Section 2 provides instructions for installing and connecting the centrifuge.
- Section 3 contains centrifuge operating procedures.
- Section 4 lists possible malfunctions, together with probable causes and suggested corrective actions.
- Section 5 contains procedures for routine operator care and maintenance, as well as a brief list of supplies and replacement parts.

NOTE

If the centrifuge is used in a manner other than specified in this manual, the safety and performance of this equipment could be impaired. Further, the use of any equipment other than that recommended by Beckman Coulter has not been evaluated for safety. Use of any equipment not specifically recommended in this manual and/or the applicable rotor manual is the sole responsibility of the user.

CONVENTIONS

Certain symbols are used in this manual to call out safety-related and other important information. These international symbols may also be displayed on the centrifuge and are reproduced and described below and on the inside of the front cover.

NOTES, CAUTIONS, AND WARNINGS

NOTE

Used to call attention to important information that should be followed during installation, use, or servicing of this equipment.



CAUTION

Used to indicate a potentially hazardous situation which, if not avoided, may result in minor or moderate injury and/or mechanical damage. It is also used to alert against unsafe practices.



WARNING

Used whenever an action or condition may potentially cause personal injury or loss of life. Mechanical damage may also result.



WARNING

Indicates high voltage or risk of electric shock. Refer servicing of all areas displaying either symbol to service personnel.

CFC-FREE CENTRIFUGATION



To ensure minimal environmental impact, no CFCs are used in the manufacture or operation of Microfuge 22R centrifuges.

RADIO INTERFERENCE

This equipment has been tested and found to comply with the limits for a Class A digital device, pursuant to Part 15 of FCC Rules. These limits are designed to provide reasonable protection against harmful interference when the equipment is operated in a commercial environment. This equipment generates, uses, and can radiate radio frequency energy and, if not installed and used in accordance with this instruction manual, may cause interference to radio communications. Operation of this equipment in a residential area is likely to cause interference, in which case the user will be required to correct the interference at his own expense.

CANADIAN REGULATIONS

This equipment does not exceed the Class A limits for radio noise emissions from digital apparatus as set out in the radio interference regulations of the Canadian Department of Communications.

Le présent appareil numérique n'émet pas de bruits radioélectriques dépassant les limites applicables aux appareils numériques de Classe A prescrites dans le règlement sur le brouillage radioélectrique édicté par le Ministère des Communications du Canada.

RECYCLING LABEL



This symbol is required in accordance with the Waste Electrical and Electronic Equipment (WEEE) Directive of the European Union. The presence of this marking on the product indicates:

- 1) This symbol is required in accordance with the Waste Electrical and Electronic Equipment (WEEE) Directive of the European Union. The presence of this marking on the product indicates:
- 2) the device is not to be disposed via the municipal waste collection system of any member state of the European Union.

It is very important that customers understand and follow all laws regarding the proper decontamination and safe disposal of electrical equipment. For Beckman Coulter products bearing this label please contact your dealer or local Beckman Coulter office for details on the take back program that will facilitate the proper collection, treatment, recovery, recycling and safe disposal of the device.



Description

CENTRIFUGE FUNCTION, SPECIFICATIONS, AND SAFETY FEATURES

CENTRIFUGE FUNCTION

CENTRIFUGE FUNCTION

The Beckman Coulter Microfuge 22R (Figure 1-1) is a microprocessor-controlled refrigerated benchtop centrifuge that generates centrifugal forces required for a wide variety of applications. Together with the Beckman Coulter rotors, designed specifically for use in this centrifuge, applications include:

- Nucleic acid plasmids and bacteriophages isolation.
- Routine processing such as sample preparations, pelleting, extractions, purifications, concentrations, phase separations, and receptor binding.
- Virus isolation.
- Rapid sedimentation of protein precipitates, large particles, and cell debris.
- Preparation of subcellular organelles such as mitochondria, granules, and crude microsomes.
- Cell isolation.

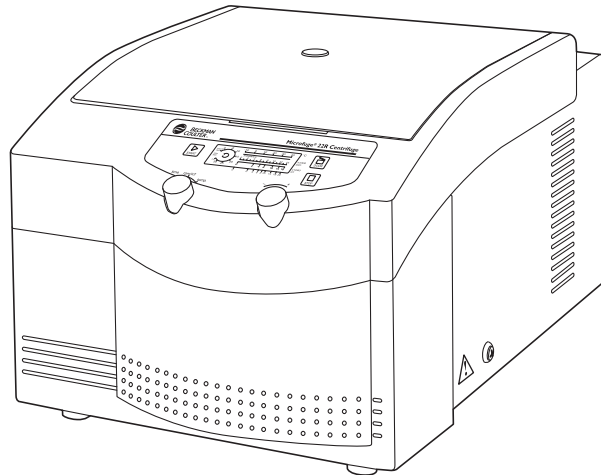

Figure 1-1. The Microfuge 22R Centrifuge

SPÉCIFICATIONS



Only values with tolerances or limits are guaranteed data. Values without tolerances are informative data, without guarantee.

Set speed	500 to 14 000 rpm
Set time	to 30 min, continuous run (∞), or pulse (short run)
Temperature and humidity	
Temperature setting	-10 to +40°C (in 2°C increments)
Operating temperature	4°C to ambient
Ambient temperature range	4 to 35°C
Ambient temperature range for optimum operation	4 to 25°C
Humidity restrictions	<80% (noncondensing)
Dimensions	
Width	36.5 cm (14.4 in.)
Depth	58.5 cm (23.0 in.)
Height, door closed	30.0 cm (11.8 in.)
Height, door open.	61.0 cm (24.0 in.)
Weight	41.0 kg (90.4 lb)
Ventilation clearances (sides and rear).	7.6 cm (3.0 in.)
Electrical requirements	220–240V~ 3.5A. 50–60 Hz
	120 V~ 6.9 A. 60 Hz
	100 V~ 8.5 A. 50–60 Hz
Electrical supply	Class I
Maximum heat dissipation into room	
under steady-state conditions	2150Btu/hr
Noise level 0.91 m (3 ft) in front of centrifuge	58 dBa
Installation (overvoltage) category	II
Pollution degree.	2*

*Normally only nonconductive pollution occurs; occasionally, however, a temporary conductivity caused by condensation must be expected.

AVAILABLE ROTORS

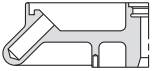
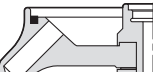
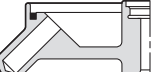
Refer to the applicable rotor manuals for complete rotor descriptions.

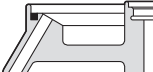
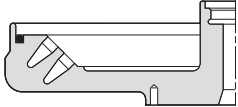
Rotor Profile and Description		Max RPM	Max. RCF ($\times g$)	Max Capacity	Rotor Manual Number
F301.5 Fixed Angle (45° Angle)	$r_{\max} = 99.5$ mm 	14,000	21,920	30 \times 2.2 mL	MMR-TB-002
F241.5P Fixed Angle (45° Angle)	$r_{\max} = 82.5$ mm 	14,000	17,970	24 \times 2.2 mL	MM-TB-001
F241.5 Fixed Angle (45° Angle)	$r_{\max} = 82.5$ mm 	14,000	17,970	24 \times 2.2 mL	MSR-TB-001
S241.5 Swinging Bucket	$r_{\max} = 73.5$ mm 	14,000	16,220	24 \times 2.2 mL	MMR-TB-003
F40.25 Fixed Angle (30° Angle)	$r_{\max} = 80.0$ mm 	14,000	17,530	40 \times 200/ 400 μ L	MMR-TB-004
F12x8.2 Fixed Angle (45° Angle)	r_{\max} : Outer row, tubes 1 and 8 Inner row, tubes 1 and 8 Outer row, tubes 4 and 5 Inner row, tubes 4 and 5 	14,000	20,800 19,590 20,070 18,820	96 \times 200 mL	MMR-TB-005

SAFETY FEATURES

Microfuge 22R centrifuges have been designed and tested to operate safely indoors at altitudes up to 2,000 m (6,562 ft).

Instrument safety features include:

- The door has an electromechanical door-locking mechanism to prevent operator contact with spinning rotors. When the door is closed it locks automatically. It can be unlocked only by pressing the [DOOR] key, an opened only when the power is on and the rotor is at rest.
- An imbalance detector monitors the rotor during the run, causing automatic shutdown if rotor loads are severely out of balance. An IMBALANCE notice appears on the display. At low speeds, an incorrectly loaded rotor can cause imbalance. Rotor instability can also occur if the centrifuge is moved while running, or if it is not resting on a level surface.

GROUND WIRE CHECK

There is a ground screw on the rear panel of 50-Hz instruments. A ground wire check can be performed using an appropriate measuring instrument.

NAME RATING PLATE

The name rating plate is affixed to the rear of the centrifuge. Check that the line voltage agrees with the voltage listed on this name rating plate before connecting the centrifuge. Always mention the serial number and the model number shown when corresponding with Beckman Coulter regarding your centrifuge. (The serial number is also on the inside of the door.)

CHASSIS

HOUSING

The housing is a sheet-steel casing. The control panel is covered by a protective overlay made of coated polycarbonate.

DOOR

The sheet-steel door has a strobe port for speed verification. A gasket system around the chamber opening assures sealing. (Centrifuge gaskets have not been designed as bioseals for aerosol containment.) An electromechanical door lock system keeps the door locked when a run is in progress and can be opened only when the rotor is stopped. In the event of a power failure, the door lock can be manually tripped for sample recovery (see Section 4, Troubleshooting).

ROTOR CHAMBER

The rotor chamber is made of stainless steel for safety and easy cleaning.

DRIVE

The asynchronous direct-drive motor is brushless for low maintenance. A tie-down screw secures the rotor to the drive shaft. The resilient suspension ensures that loads will not be disturbed by vibration, and prevents damage to the drive shaft if an imbalance occurs during centrifugation.

TEMPERATURE SENSING AND CONTROL

With the power on, the temperature control system is activated when the door is closed. The run temperature can be set between -10 and $+40^{\circ}\text{C}$. If no set temperature is entered, the centrifuge automatically selects the last entered temperature. A thermistor in the rotor chamber continuously monitors chamber temperature.

NOTE

In the unlikely event of a complete cooling system failure, the drive will switch off if the chamber temperature reaches 50°C . Restarting the centrifuge will not be possible until the chamber is cooled.

CONTROLS AND INDICATORS POWER SWITCH

POWER SWITCH

A two-position rocker switch (I, on; O, off), located on the back panel, controls electrical power to the centrifuge.

CONTROL PANEL

The control panel (Figure 1-2) is mounted at an angle on the centri-fuge front for easy visibility and access. Run parameters are selected using front-mounted knobs and are displayed on the panel.

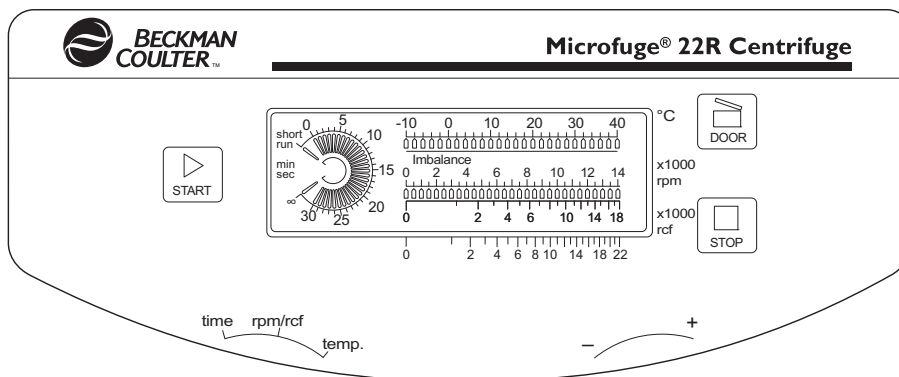
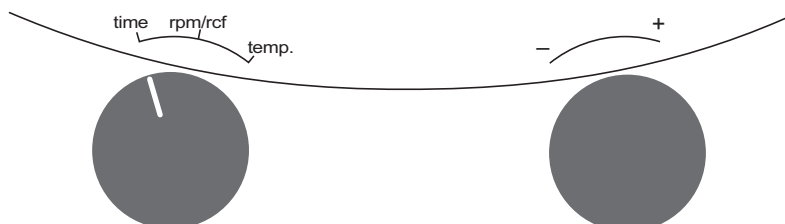

Figure 1-2. The Control Panel

Control Knobs

Run parameters are set with the control knobs. The left-hand knob is used to select the parameter (time, speed, or temperature), then values are set using the right-hand knob.



Parameter Settings

TIME

Operation in any of three modes can be selected:

- A timed run can be set for any run time up to 30 minutes in 1-minute increments. Lighted bars count down time remaining and “min” is displayed. Runs can be stopped at any time by pressing the STOP key.

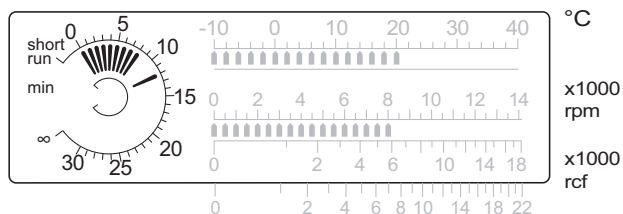

- A continuous (hold) run can be selected by turning the timer to 8. Lighted bars count elapsed run time in 1-minute increments, and “min” is displayed. After 30 minutes the timer will stop showing elapsed time, but the run will continue until the STOP key is pressed.

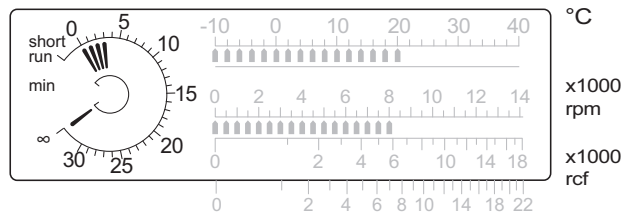

- A continuous (hold) run can be selected by turning the timer to 8. Lighted bars count elapsed run time in 1-minute increments, and “min” is displayed. After 30 minutes the timer will stop showing elapsed time, but the run will continue until the STOP key is pressed.

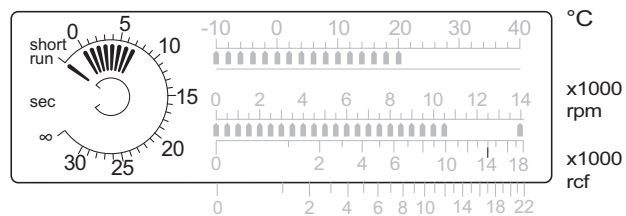

- A pulse run can be selected by setting the timer to the short run position. The centrifuge will accelerate to the maximum speed when START is pressed and held, decelerating when the key is released. Lighted bars count elapsed run time in 1-second increments, and “sec” is displayed.

TEMPERATURE

Run temperature, between -10 and $+40^{\circ}\text{C}$, can be selected in 2°C increments. The entered temperature is indicated by an LCD light bar on the display. Actual temperature is indicated during the run by a sequence of lighted bars.

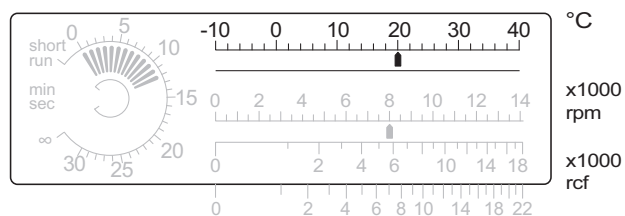

If the temperature is reset below the existing temperature while a run is in progress, the new set temperature is indicated by a flashing bar.

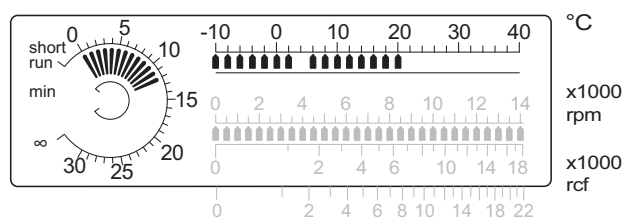

SPEED

Run temperature, between -10 and +40°C, can be selected in 2°C increments. The entered temperature is indicated by an LCD light bar on the display. Actual temperature is indicated during the run by a sequence of lighted bars.

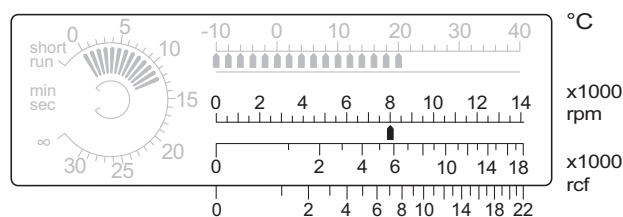

Actual speed is indicated during the run by a sequence of lighted bars.

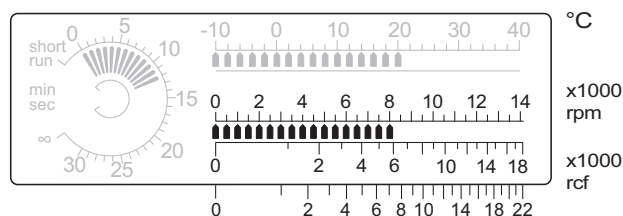

If the speed is set below the existing run speed while a run is in progress, the new set speed is indicated by a flashing bar and the drive decelerates to the new value.

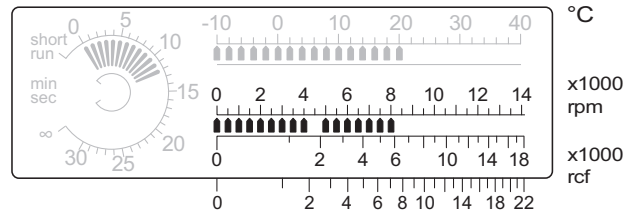

Door



When pressed, this key releases the latch mechanism and allows the door to be opened (the rotor must be stopped, the power must be on, and the key light on).

Start



- With the TIME control set for a timed or continuous run, pressing and releasing the switch starts the centrifuge run; the rotor accelerates to the set speed and continues until the time runs down (or the STOP switch is pressed). A deceleration in process can be stopped by pressing the START key; this will restart the centrifuge.
- With the TIME control set for a short run (pulse), pressing and holding the switch causes the installed rotor to accelerate to maximum or set speed and spin as long as the key is pressed. Deceleration begins when the key is released.

Stop

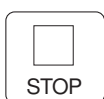

Pressing this switch will cause the centrifuge to decelerate to a complete stop.

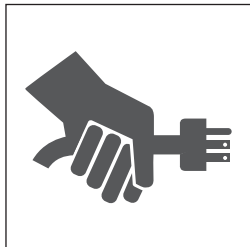

INSTALLING THE CENTRIFUGE



WARNING

This centrifuge weighs 41.0 kg (90.4 lb). DO NOT attempt to lift or move it without assistance from another person.



WARNING

Do not place the centrifuge near areas containing flammable reagents or combustible fluids. Vapors from these materials could enter the centrifuge's air system and be ignited by the motor. No hazardous materials should be handled or stored within the 30-cm (1-ft) boundary surrounding the centrifuge. Maintain a 7.6-cm (3-in.) clearance envelope around the centrifuge. No persons should be within this clearance envelope while the centrifuge is operating, except to adjust centrifuge controls, if necessary.

Carefully remove the centrifuge and accessories from the shipping container. Save the container and packing materials for possible future relocation or storage.

- Select a location away from heat-producing laboratory equipment, with sufficient ventilation to allow for heat dissipation.

- Position the centrifuge on a level surface, such as a sturdy table or laboratory bench that can support the weight of the centrifuge (41.0 kg/90.4 lb) and resist vibration.
- In addition to space for the centrifuge itself (see Figure 2-1 for dimensions), allow 7.6-cm (3-in.) clearances at the sides and back of the centrifuge to ensure sufficient air circulation. The centrifuge must have adequate air ventilation to ensure compliance to local requirements for vapors produced during operation.

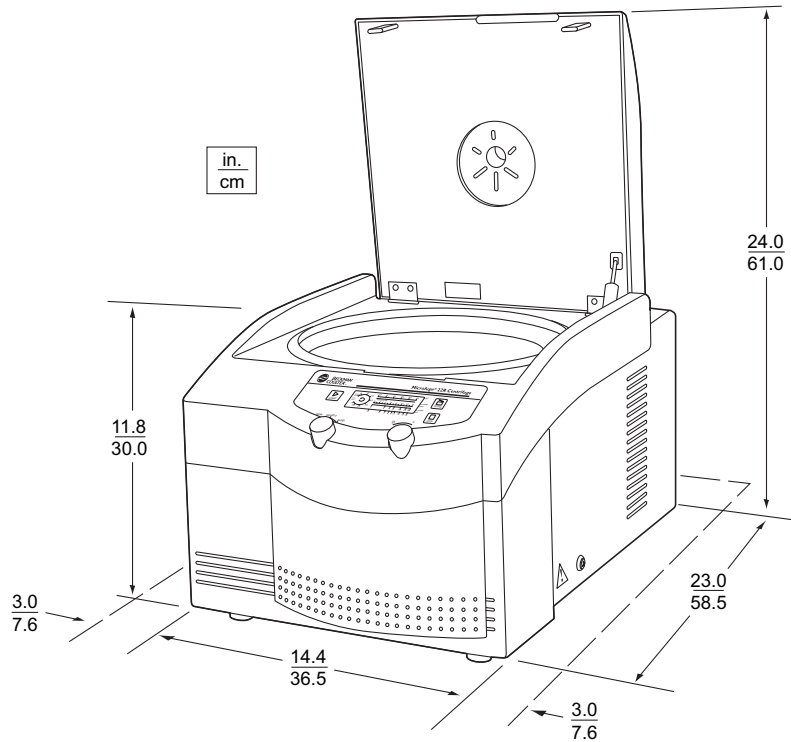

Figure 2-1. Dimensions of the Microfuge 22R Centrifuge

- Ambient temperatures during operation should not be lower than 4°C (39°F) or higher than 35°C (95°F). Relative humidity should not exceed 80% (noncondensing).

NOTE

During transport between areas with varying temperatures, condensation may occur inside the centrifuge. Allow sufficient drying time before running the centrifuge.

TRANSPORTATION SAFETY DEVICES

The centrifuge has a shipping screw on the bottom plate and a plastic foam stabilizer installed in the rotor chamber to prevent damage to the drive motor during transit. When installation of the centrifuge is complete:

- Tilt the centrifuge back and remove the black shipping screw from the bottom plate.
- Unscrew the tie-down bolt and remove the stabilizer from inside the chamber.

Save the shipping screw to use during future relocation of the centrifuge.

ELECTRICAL REQUIREMENTS

100-V centrifuge	95–110 V~, 8.5 A, 50–60 Hz
120-V centrifuge	108–132 V~, 6.9 A, 60 Hz
230-V centrifuge	198–263 V~, 3.5A, 50–60 Hz
Power cord.	a 2.5-m (8-ft) power cord with grounded plug is supplied with the centrifuge

To reduce the risk of electrical shock, this centrifuge uses a three-wire electrical cord and plug to connect the centrifuge to earth-ground. To preserve this safety feature:

- Make sure that the matching wall outlet receptacle is properly wired and earth-grounded. Check that the line voltage agrees with the voltage listed on the name rating plate affixed to the centrifuge. Then plug in both ends of the centrifuge power cord.
- Never use a three-to-two wire plug adapter.
- Never use a two-wire extension cord or a two-wire non-grounding type of multiple-outlet receptacle strip.
- If there is any question about voltage, have a qualified service person measure it under load while the drive is operating.

To ensure safety the centrifuge should be wired to a remote emergency switch (preferably outside the room where the centrifuge is housed, or adjacent to the exit from that room), in order to disconnect the centrifuge from the main power source in case of a malfunction.

TEST RUN

We recommend that you make a test run to ensure that the centrifuge is in proper operating condition following shipment. See Section 3 for instructions on operating the centrifuge.

After completing the test run, return the preaddressed warranty card included with this literature. This will validate the centrifuge warranty and ensure your receipt of further information regarding new accessories and/or modifications as they become available

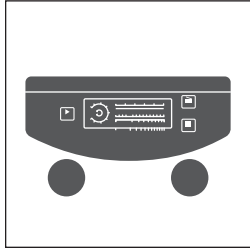

Operation

**WARNING**

Handle infectious samples according to good laboratory procedures and methods to prevent spread of disease. Because spills, operator error, or tube failure may generate aerosols, observe proper safety precautions for aerosol containment. Do not run toxic, pathogenic, or radioactive materials in this centrifuge without taking appropriate safety precautions. Biosafe containment should be used when Risk Group II materials (as identified in the World Health Organization Laboratory Biosafety Manual) are handled; materials of a higher group require more than one level of protection

**WARNING**

The centrifuge must not be used in the vicinity of flammable liquids or vapors, and such materials should not be run in the centrifuge. Never bring any flammable substances within the 30-cm (1-ft) boundary surrounding the centrifuge. Do not lean on the centrifuge or place items on the centrifuge while it is operating. During operation you should not come within the 7.6-cm (3-in.) clearance envelope except to adjust centrifuge controls, if necessary.

PREPARATION AND LOADING

Refer to the applicable rotor manual for instructions on preparing the rotor for centrifugation.

Action

1. Press the power switch to on (I).
2. Press **DOOR** and lift the door up.

Result

Power is applied to the centrifuge; all LEDs on the control panel light up momentarily.

The door will remain open.



CAUTION

Do not drop the rotor onto the drive shaft. The shaft can be bent if the rotor is forced sideways or dropped onto it. Install the rotor by centering it over the shaft and carefully lowering it straight down.

3. Install the rotor according to instructions in the rotor manual. *Always run the rotor with a balanced load.*

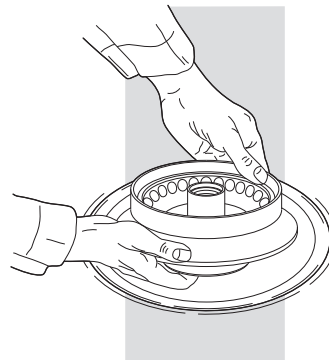

Action

- Secure the rotor to the drive shaft with the tie-down screw by holding the rotor with one hand while turning the T-handle rotor wrench to the right (clockwise).

Result

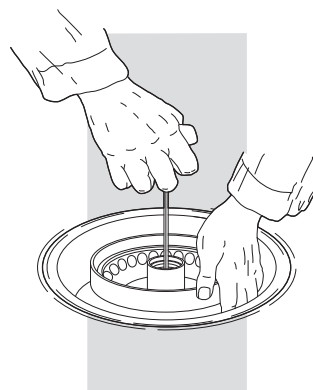
**NOTE**

If the rotor is left in the centrifuge between runs, make sure it is seated on the drive shaft and the tie-down screw is tight before each run.

Approx-imately every 20 runs, or once a day, loosen the tie-down screw and retighten it to ensure proper connection between the rotor and the shaft.

- Install the rotor lid and secure it by turning the knob clockwise.
- Close the centrifuge door and push firmly down on it until you hear the latches engage.

STARTING A TIMED OR HOLD RUN

Action

1. Turn the parameter selection knob to rpm/rcf, then use the +/- knob to select a speed (up to 14,000 rpm).

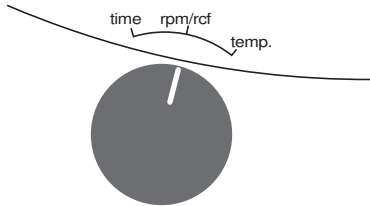

Result

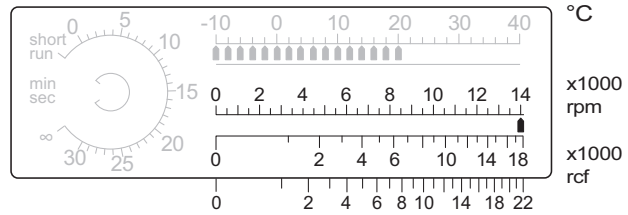

2. Turn the parameter selection knob to time, then use the +/- knob to set the required run time (up to 30 minutes) for a timed run or to ∞ for a hold run.

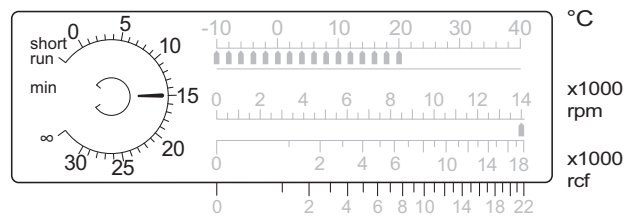
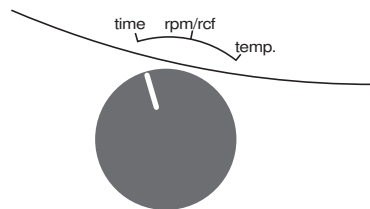

3. Turn the parameter selection knob to temp. then use the +/- knob to set the required temperature (between -10 °C and +40 °C).

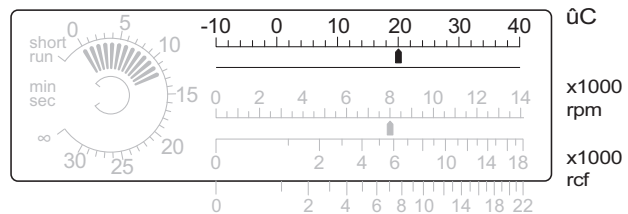
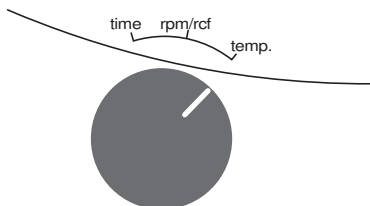

Action

4. Check that the door is shut and securely latched.
5. Press **START**.

Result

- Timed run—Lighted bars count down time remaining, in 1-minute increments, and “min” is displayed. Lighted bars on the speed scale indicate rotor speed (rpm \times 1000 on upper scale, rcf \times 1000 on lower scale).

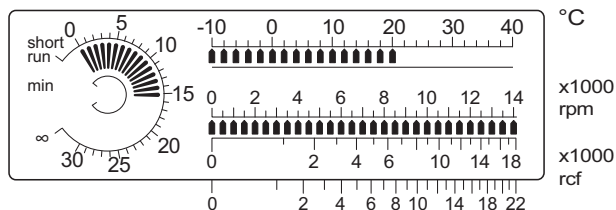
**CAUTION**

Do not lift or move the centrifuge while the rotor is spinning.

- Continuous (hold) run—Lighted bars count up elapsed run time in 1-minute increments and “min” is displayed. (After 30 minutes the timer will stop showing elapsed time, but the run will continue until the STOP key is pressed.) Lighted bars on the speed scale indicate rotor speed (rpm \times 1000 on upper scale, rcf \times 1000 on lower scale).

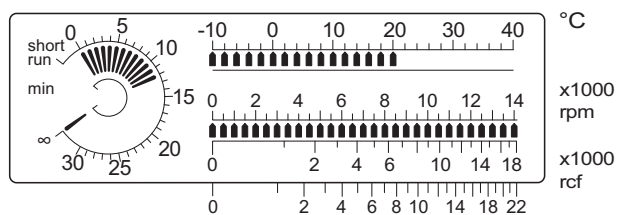
**WARNING**

Do not attempt to override the door interlock system while the rotor is spinning.

Action

Result

A timed run ends automatically when the set time counts down to zero. You can end a hold or timed run in progress for any reason by pressing the **STOP** key.

6. *After the rotor stops spinning* press **DOOR**.

The door latch is released. Open the door and unload the rotor.

STARTING A PULSE RUN

Two pulse-run modes are available.

PULSE MODE 1

This mode will accelerate to the maximum speed and maintain that speed as long as the START key is held.

Action

Result

1. Check that the door is shut and securely latched.
2. Turn the parameter selection knob to time, then select the short run position.

A lighted bar is at the “short run” position, and “sec” is displayed.



CAUTION

Do not lift or move the centrifuge while the rotor is spinning.

Action

3. Press and hold the **START** key.

Result

The centrifuge accelerates to the maximum speed and continues as long as the key is pressed, decelerating when the key is released. Lighted bars count elapsed run time in 1-second increments, and “sec” is displayed.

4. *After the rotor stops spinning* press **DOOR**.

The door latch is released. Open the door and unload the rotor.



WARNING

Do not attempt to override the door interlock system while the rotor is spinning

PULSE MODE 2

This pulse-run mode will accelerate to the set speed when START is pressed and run at that speed for 30 seconds, then decelerate to stop.

Action

1. Select a run speed (up to 14,000 rpm).

Result

2. Turn the parameter selection knob to time, then select the short run position.

A lighted bar is at the “short run” position, and “sec” is displayed.

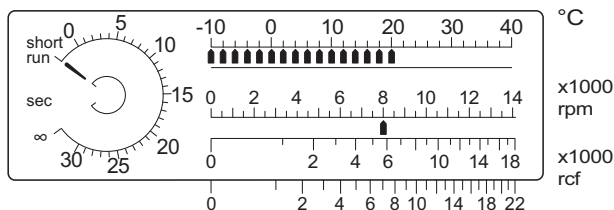

3. Check that the door is shut and securely latched.

Action

4. Press and release the **START** key.

Result

The centrifuge accelerates to the maximum speed and continues as long as the key is pressed, decelerating when the key is released. Lighted bars count elapsed run time in 1-second increments, and “sec” is displayed.

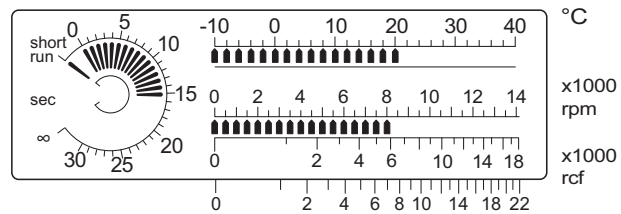

CAUTION

Do not lift or move the centrifuge while the rotor is spinning.

5. After the rotor stops spinning press **DOOR**.

The door latch is released. Open the door and unload the rotor.



WARNING

Do not attempt to override the door interlock system while the rotor is spinning.

UNLOADING

After completing a run, unload the rotor according to instructions in the rotor manual.



CAUTION

If disassembly reveals evidence of leakage, you should assume that some fluid escaped the rotor. Apply appropriate decontamination procedures to the centrifuge and accessories.



Troubleshooting

NOTE

It is your responsibility to decontaminate the centrifuge, as well as any rotors and accessories, before requesting service by Beckman Coulter representatives.

TROUBLESHOOTING

Malfunctions that may occur are described in Table 4-1, along with probable causes and corrective actions required. Possible causes for each problem are listed in the probable order of occurrence. Perform the recommended corrective action in sequence, as listed. If you are unable to correct the problem, call your local Beckman Coulter representative.

To help diagnose and correct the problem, note as much information about the situation as possible:

- The operating situation when the error occurred (such as speed or load type)
- Any unusual environmental and/or operating conditions (such as ambient temperature or voltage fluctuations)
- Any other useful information.

Table 3-1. Troubleshooting Chart

Problème	Cause probable	Mesures recommandées
No indication on displays	Power not on	Plug in power cord; turn power on (I).
	Fuse blown	Change both fuses as described in Section 5, Care and Maintenance.
	Mechanical failure	Call Beckman Coulter Field Service.
La centrifugeuse ne peut pas démarrer	Mechanical failure	Call Beckman Coulter Field Service.
DOOR key light blinks and centrifuge will not start	Door not closed properly	Press the DOOR key to open the door, then close the door again, pressing down firmly to ensure both latches engage.
Rotor cannot achieve set speed	Line voltage below rating	Measure line voltage while centrifuge is operating.
	Electrical failure	Check connections; call Beckman Coulter Field Service.
	Mechanical failure	Call Beckman Coulter Field Service.
Door will not open	Le rotor tourne	Wait until rotor stops.
	L'alimentation est coupée (arrêt)	Plug in power cord; turn power on (I). If power cannot be restored, see ACCESSING THE ROTOR IN CASE OF POWER FAILURE, below, to retrieve your sample.

ERROR MESSAGES

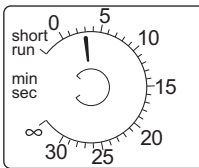

Ceci indique l'erreur n 3

If a problem occurs during operation, the three icon lights (START, DOOR, and STOP) will flash and a lighted bar on the TIME display will point to the error number. Refer to Table 4-2 to determine the nature of the problem and recommended actions. If you are unable to correct the problem, call your Beckman Coulter Field Service representative.

Table 3-2. Error Message Chart.
 If the recommended action does not correct the problem, call Beckman Coulter Field Service.

Numéro d'erreur	Description	Mesures recommandées
1	Bad tachometer reading	Mettre l'instrument à l'arrêt (O) et attendre que le rotor soit à l'arrêt complet. Ensuite, remettre l'instrument en marche (I) pour le réinitialiser.
2	No tachometer signal	
3	Drive is not enabled	
4	Door does not open after door relay is active	Turn the power off (O). Verify that the rotor is completely stopped, then open the door using the procedures under ACCESSING THE ROTOR IN CASE OF POWER FAILURE, below. Close the door firmly, and turn the power back on (I).
5 thru 11	Internal fault	Turn the power off (O) and wait for the rotor to come to a complete stop, then turn the power back on (I) to reset.
12	Imbalance detected	Turn the power off (O) and wait for the rotor to come to a complete stop. Check to be sure the rotor is in good condition and is loaded symmetrically around the center of rotation, with containers of equal weight and density opposite each other. Turn the power back on (I) to reset.
13	Overtemperature	1. Check that ambient temperature is within the limits shown in SPECIFICATIONS. 2. Check air inlets and exhausts for obstructions. After the motor has cooled, restart.
14	Rotor chamber overtemperature	

ACCESSING THE ROTOR IN CASE OF POWER FAILURE

If the facility power fails you will have to restart the run when the power is restored. In the event of an extended power failure, it may be necessary to trip the door-locking mechanism manually to remove the rotor and retrieve your sample.



WARNING

The following procedure may expose the operator to the possibility of contact with a spinning rotor. Turn the power off (O) and disconnect the centrifuge from the main power source before proceeding. Never attempt to override the door interlock system while the rotor is spinning.

Action

1. Turn the power switch to off (O) and unplug the power cord from the power source.
2. Make sure that the rotor is not spinning.
3. Locate the emergency access device on the side panel.
4. Turn the screw to the left (counterclockwise) until you can grip the release device with your fingers.
5. Pull on the device (do not pull on the screw) to release the latch.
6. Repeat steps 3 through 5 on the opposite side panel.

Result

No indicators are lit.

No sound or vibration comes from the centrifuge.

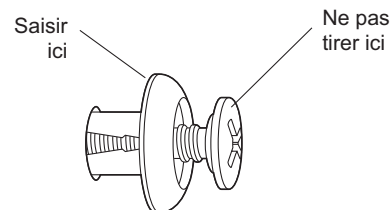

The latch releases and the door can be opened.

If the rotor is still spinning, *close the door and wait until it stops before attempting to remove it.*



WARNING

Never try to slow or stop the rotor by hand.

7. Open the door and remove the rotor.
8. Reinsert the release devices and tighten the retaining screws.

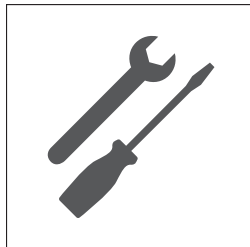

Care and Maintenance

For maintenance not covered in this manual, contact Beckman Coulter Field Service (1-800-742-2345 in the U.S.A.; customers outside the United States should contact their local Beckman Coulter representative). Refer to the rotor manual and Chemical Resistances (publication IN-175) for instructions on the care of rotors and rotor accessories.

NOTE

It is your responsibility to decontaminate the centrifuge, as well as any rotors and accessories, before requesting service by Beckman Coulter representatives.



WARNING

Any maintenance procedure or servicing of this equipment that requires removal of any covers can expose parts which involve the risk of electric shock or personal injury. Make sure that the power switch is off (O) and the centrifuge is disconnected from the main power source, and refer such servicing to qualified service personnel.

Do not use alcohol or other flammable substances in or near operating centrifuges.

MAINTENANCE

PREVENTIVE MAINTENANCE

Perform the following procedures regularly to ensure satisfactory performance and long service life of the centrifuge.

- Regularly inspect the interior of the rotor chamber for accumulations of sample or dust. Clean as required (see CLEANING, below), as these accumulations can result in rotor vibrations.
- Regularly check the air intake and exhaust vents for obstructions. Keep vents clear and clean.

REPLACING FUSES

The fuse holder is located on the back of the centrifuge, beside the power cord receptacle.



CAUTION

For continued protection against the risk of fire, replace fuses only with the listed fuses (6.3AT, 365637; 12.5AT, 368975; 10AT, 365638).

Action

1. Turn the power switch to off (O) and unplug the power cord from the power source.

Result

No indicators are lit.

Action

2. Use your fingernails or a small screwdriver to press in on the fuse holder latches.

Result

Latches release and the fuse holder can be pulled out.

3. Pull the fuse holder straight out. Fuses are accessible.
4. Pull the fuse straight out of the fuse holder.
5. Carefully insert a new fuse. Press it straight in until it seats in the fuse holder.
6. Repeat steps 4 and 5 for the other fuse.
7. Position the fuse holder in the opening and press it in until it seats.

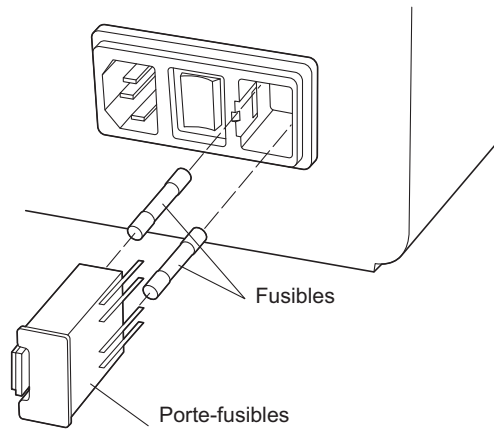

CLEANING



Frequent cleaning will ensure proper operation and prolong the life of the centrifuge. *Always clean up spills when they occur to prevent corrosives or contaminants from drying on component surfaces.*

NOTE

Before using any cleaning methods except those recommended by the manufacturer, users should check with the manufacturer that the proposed method will not damage the equipment.

- To prevent accumulations of sample and/or dust, keep the interior of the rotor chamber clean and dry by frequent wiping with a cloth or paper towel.
- Clean the drive shaft, shaft cavity, threads, and the tie-down screw at least once a week using a mild detergent such as Solution 555 (339555) and a soft brush. Dilute the detergent 10 to 1 with water. Rinse thoroughly and dry completely. Lubricate the drive shaft with Spinkote (306812) after cleaning.
- Wash the bowl using a mild detergent such as Solution 555. Rinse thoroughly and dry completely.
- Clean the centrifuge case and door by wiping with a cloth dampened with Solution 555. Do not use acetone or other solvents.

DECONTAMINATION



If the centrifuge and/or accessories are contaminated with radioactive or pathogenic solutions, perform appropriate decontamination procedures. Refer to *Chemical Resistances* to be sure the decontamination method will not damage any part of the centrifuge.

STERILIZATION AND DISINFECTION

Ethanol (70%)* may be used on the centrifuge surface. See Chemical Resistances for more information regarding chemical resistance of centrifuge and accessory materials.

While Beckman Coulter has tested these methods and found that they do not damage the centrifuge, no guarantee of sterility or disinfection is expressed or implied. When sterilization or disinfection is a concern, consult your laboratory safety officer regarding proper methods to use.

STORAGE AND TRANSPORT

STORAGE

Before storing a centrifuge for an extended period, return it to the original shipping container to protect it from dust and dirt. Temperature and humidity conditions for storage should meet the environmental requirements described under SPECIFICATIONS, in Section 1.

TRANSPORT

Install the plastic foam stabilizer in the rotor chamber and the two shipping screws in the bottom plate (removed during installation) to prevent damage to the drive motor during transit.

RETURNING A CENTRIFUGE

The image shows a Returned Goods Authorization (RGA) form. At the top right, the letters "RGA" are printed. Below this, there is a header section with several lines for text entry, including a space for a signature and a date. Below the header is a table with multiple columns and rows, designed for recording details of the returned items. The table has a grid-like structure with some cells containing small text or numbers.

Before returning a centrifuge or accessory for any reason, prior permission (a Returned Goods Authorization form) must be obtained from Beckman Coulter, Inc. Contact your local Beckman Coulter office to obtain the RGA form and for packaging and shipping instructions.

To protect our personnel, it is the customer's responsibility to ensure that all parts are free from pathogens and/or radioactivity. Sterilization and decontamination must be done before returning the parts.

*All parts must be accompanied by a signed note, plainly visible on the outside of the box, stating that they are safe to handle and that they are not contaminated with pathogens or radioactivity. **Failure to attach this notification will result in return or disposal of the items without review of the reported problem.***

SUPPLY LIST

NOTE

Publications referenced in this manual can be obtained by calling Beckman Coulter at 1-800-742-2345 in the United States, or by contacting your local Beckman Coulter office.

Contact Beckman Coulter Sales (1-800-742-2345 in the United States; worldwide offices are listed at the back of this manual) for detailed information on ordering parts and supplies. For your convenience, a partial list is given below. Refer to the rotor manual for materials and supplies needed for rotors.

REPLACEMENT PARTS

Rotor tie-down screw	365806
T-handle wrench	365636
Fuse, 6.3AT, 230 V	365637
Fuse, 12.5AT, 100 V	365975
Fuse, 10AT, 120 V	365638

SUPPLIES

Spinkote lubricant (2 oz)	306812
Solution 555 (1 qt)	339555

MICROFUGE SERIES CENTRIFUGE WARRANTY

Subject to the exceptions and upon the conditions specified below and the warranty clause of the Beckman Coulter terms and conditions in effect at the time of sale, Beckman Coulter agrees to correct either by repair or, at its election, by replacement, any defects of material or workmanship which develop within one (1) year after delivery of a Microfuge series centrifuge (the product), to the original buyer by Beckman Coulter or by an authorized representative, provided that investigation and factory inspection by Beckman Coulter discloses that such defect developed under normal and proper use.

Some components and accessories by their nature are not intended to and will not function for as long as one (1) year. A complete list of such components or accessories is maintained at the factory and at each Beckman Coulter District Sales Office. The lists applicable to the products sold hereunder shall be deemed to be part of this warranty. If any such component or accessory fails to give reasonable service for a reasonable period of time, Beckman Coulter will repair or, at its election, replace such component or accessory. What constitutes either reasonable service and a reasonable period of time shall be determined solely by Beckman Coulter.

REPLACEMENT

Any product claimed to be defective must, if requested by Beckman Coulter, be returned to the factory, transportation charges prepaid, and will be returned to Buyer with the transportation charges collect unless the product is found to be defective, in which case Beckman Coulter will pay all transportation charges.

CONDITIONS

Beckman Coulter shall be released from all obligations under all warranties, either expressed or implied, if the product(s) covered hereby are repaired or modified by persons other than its own authorized service personnel, unless such repair in the sole opinion of Beckman Coulter is minor, or unless such modification is merely the installation of a new Beckman Coulter plug-in component for such product(s).

DISCLAIMER

IT IS EXPRESSLY AGREED THAT THE ABOVE WARRANTY SHALL BE IN LIEU OF ALL WARRANTIES OF FITNESS AND OF THE WARRANTY OF MERCHANTABILITY AND THAT NEITHER BECKMAN COULTER, INC. NOR ITS SUPPLIERS SHALL HAVE ANY LIABILITY FOR SPECIAL OR CONSEQUENTIAL DAMAGES OF ANY KIND WHATSOEVER ARISING OUT OF THE MANUFACTURE, USE, SALE, HANDLING, REPAIR, MAINTENANCE, OR REPLACEMENT OF THE PRODUCT.



Beckman Coulter, Inc. • 250 S. Kraemer Blvd. • Brea, California 92821
Sales and Service: 1-800-742-2345 • Internet: www.beckmancoulter.com

©2013 Beckman Coulter, Inc.
tous droits réservés