

ÄKTA™ start

Operating Instructions

Original instructions



Page intentionally left blank

Table of Contents

1	Introduction	7
1.1	About this manual	8
1.2	Important user information	9
1.3	Regulatory information	11
1.3.1	<i>EU Directives</i>	12
1.3.2	<i>Eurasian Customs Union</i>	13
1.3.3	<i>Regulations for USA and Canada</i>	14
1.3.4	<i>Other regulations and standards</i>	15
1.4	Associated documentation	17
1.5	Abbreviations	20
2	Safety instructions	21
2.1	Safety precautions	22
2.2	Labels	30
2.3	Emergency procedures	34
2.4	Recycling procedures	36
2.5	Declaration of Hazardous Substances (DoHS)	37
3	System description	39
3.1	System overview	40
3.2	Instrument	44
3.3	Instrument Display	47
3.3.1	<i>Overview of the Instrument Display</i>	48
3.3.2	<i>Description of Method run</i>	53
3.3.3	<i>Description of Create method</i>	56
3.3.4	<i>Description of Settings and service</i>	57
4	Installation	64
4.1	Space requirements	65
4.2	Transport ÄKTA start and Frac30	67
4.3	Unpack ÄKTA start and Frac30	69
4.4	Accessories package	79
4.5	Install ÄKTA start	80
5	Prepare the system for a run	88
5.1	Flow path overview	89
5.2	Start the instrument	92
5.3	Calibration guidelines	93
5.4	System performance	95
5.4.1	<i>System performance method</i>	96
5.4.2	<i>System performance method from ÄKTA start</i>	98
5.4.3	<i>System performance method from UNICORN start</i>	102
5.4.4	<i>Switch valve timing</i>	105
5.5	Connect a column	109

Table of Contents

5.6	System methods for run preparation	113
5.6.1	<i>Pump wash A</i>	114
5.6.2	<i>Pump wash B</i>	116
5.6.3	<i>Washout fractionation tubing</i>	118
5.6.4	<i>Column preparation</i>	121
5.7	Sample application	123
5.8	Prepare the Fraction collector	134
5.9	Operation in a cold room	138
5.10	Starting a run	140
6	Operation from the Instrument Display	142
6.1	Introduction	143
6.2	Fractionation	146
6.3	Perform a manual run	149
6.3.1	<i>Manual run</i>	150
6.3.2	<i>Monitor and control the run</i>	153
6.4	Perform a method run	158
6.4.1	<i>Select a method type</i>	159
6.4.2	<i>Quick start</i>	161
6.4.3	<i>Templates</i>	167
6.4.4	<i>User defined methods</i>	175
6.4.5	<i>Prepare system methods</i>	177
6.5	Procedures after a run	180
6.6	Manage methods and files	183
6.6.1	<i>Create method</i>	184
6.6.2	<i>Handling the USB memory stick</i>	193
6.6.3	<i>BMP result file</i>	196
7	Operation from UNICORN start	198
7.1	System Control	199
7.2	Method Editor	201
7.3	Evaluation	203
7.4	Administration	204
8	Maintenance	205
8.1	Regular maintenance schedule	206
8.2	Cleaning before planned maintenance/service	209
8.3	Cleaning the system flow path	210
8.3.1	<i>Disconnect the column</i>	212
8.3.2	<i>System cleaning</i>	213
8.4	Cleaning the UV flow cell	216
8.5	Cleaning the Conductivity flow cell	218
8.6	Cleaning the valves	219
8.7	Other cleaning procedures	222
8.7.1	<i>Cleaning the inlet filters</i>	223
8.7.2	<i>Cleaning the instrument externally</i>	224
8.7.3	<i>Cleaning the Fraction collector</i>	225
8.8	Storage of the instrument	228

8.9	Replacement of tubing and filters	230
8.9.1	<i>Replace the inlet filters</i>	231
8.9.2	<i>Replace the tubing and connectors</i>	232
9	Troubleshooting	234
9.1	Introduction to troubleshooting	235
9.2	Basic troubleshooting	237
9.3	System error report	249
10	Reference information	251
10.1	Specifications	252
10.2	Chemical resistance	258
10.3	Literature	261
10.4	Health and Safety Declaration Form	262
10.5	Ordering information	264
11	Appendix	268
11.1	System Performance Report	269
	Index	272

Page intentionally left blank

1 Introduction

About this chapter

This chapter contains important user information and a list of associated documentation.

In this chapter

Section	See page
1.1 About this manual	8
1.2 Important user information	9
1.3 Regulatory information	11
1.4 Associated documentation	17
1.5 Abbreviations	20

1.1 About this manual

Purpose of this document

The *Operating Instructions* provide you with the instructions needed to install, operate and maintain the ÄKTA start system in a safe way.

Nomenclature conventions

The nomenclature used in this manual is explained in the table below.

Concept	Explanation
ÄKTA start	The instrument.
Frac30	The Fraction collector.
UNICORN™ start	The software installed on a computer.
ÄKTA start System	The entire liquid chromatography system, including instrument, Fraction collector and software.

Typographical conventions

Software items are identified in the text by ***bold italic*** text. A colon separates menu levels, thus ***File:Open*** refers to the ***Open*** command in the ***File*** menu.

Hardware items are identified in the text by **bold** text (for example, **Buffer valve**).

1.2 Important user information

Read this before operating the product



All users must read the entire *Operating Instructions* before installing, operating or maintaining the product.

Always keep the *Operating Instructions* at hand when operating the product.

Do not operate the product in any other way than described in the user documentation. If you do, you may be exposed to hazards that can lead to personal injury and you may cause damage to the equipment.

Intended use

ÄKTA start is a liquid chromatography system used for preparative purification of proteins at laboratory-scale. The system can be used for a variety of research purposes to fulfill the needs of the users in academia and the life sciences industry.

ÄKTA start is intended for research use only, and shall not be used in any clinical procedures, or for diagnostic purposes.

Prerequisites

In order to follow this manual and use the system in the manner it is intended, it is important that:

- you understand the concepts of liquid chromatography
 - you have read and understood the *Safety instructions* chapter in these *Operating Instructions*.
-

Safety notices

This user documentation contains safety notices (WARNING, CAUTION, and NOTICE) concerning the safe use of the product. See definitions below.



WARNING

WARNING indicates a hazardous situation which, if not avoided, could result in death or serious injury. It is important not to proceed until all stated conditions are met and clearly understood.



CAUTION

CAUTION indicates a hazardous situation which, if not avoided, could result in minor or moderate injury. It is important not to proceed until all stated conditions are met and clearly understood.



NOTICE

NOTICE indicates instructions that must be followed to avoid damage to the product or other equipment.

Notes and tips

Note: *A note is used to indicate information that is important for trouble-free and optimal use of the product.*

Tip: *A tip contains useful information that can improve or optimize your procedures.*

1.3 Regulatory information

Introduction

This section lists the regulations and standards that apply to the ÄKTA start system.

Manufacturing information

The table below summarizes the required manufacturing information.

Requirement	Information
Name and address of manufacturer	GE Healthcare Bio-Sciences AB, Björkgatan 30, SE 751 84 Uppsala, Sweden

In this section

Section	See page
1.3.1 EU Directives	12
1.3.2 Eurasian Customs Union	13
1.3.3 Regulations for USA and Canada	14
1.3.4 Other regulations and standards	15

1.3.1 EU Directives

Conformity with EU Directives

This product fulfills the European Directives listed below. See the EU Declaration of Conformity for the directives and regulations that apply for the CE marking.

If not included with the product, a copy of the EU Declaration of Conformity is available on request.

Directive	Title
2006/42/EC	Machinery Directive (MD)
2014/30/EU	Electromagnetic Compatibility (EMC) Directive
2014/35/EU	Low Voltage Directive (LVD)
2011/65/EU	Restriction of Hazardous Substances (RoHS) Directive

CE marking



The CE marking and the corresponding EU Declaration of Conformity is valid for the instrument when it is:

- used according to the Operating Instructions or user manuals, and
 - used in the same state as it was delivered from GE, except for alterations described in the Operating Instructions or user manuals.
-

1.3.2 Eurasian Customs Union

Introduction

This section contains additional regulatory information to comply with the Eurasian Customs Union technical regulations.

Manufacturer and importer information

The table below summarizes the manufacturer and importer information required by the Eurasian Customs Union.

Requirement	Information
Name and address of manufacturer	See <i>Manufacturing information</i>
Telephone number of manufacturer	Telephone: + 46 771 400 600
Importer and/or company for obtaining information about importer	GE Healthcare LLC GE Healthcare Life Sciences Presnenskaya nab., 10C, 12th floor RU-123 317 Moscow, Russian Federation Telephone 1: + 7 495 411 9714 Fax nr: + 7 495 739 6932 Email: LSrus@ge.com

- 1 Introduction
- 1.3 Regulatory information
- 1.3.3 Regulations for USA and Canada

1.3.3 Regulations for USA and Canada

NRTL certification



This symbol indicates that the product has been certified by Intertek, which is a US Occupational Safety and Health Administration Nationally Recognized Testing Laboratory (NRTL).

This product Conforms to UL 61010-1, and is Certified to CAN/CSA-C22.2 No. 61010-1.

1.3.4 Other regulations and standards

Introduction

This section describes the standards that apply to the ÄKTA start system.

Environmental conformity

This product conforms to the following environmental requirements.

Requirement	Title
2012/19/EU	Waste Electrical and Electronic Equipment (WEEE) Directive
China RoHS	Management Methods for the Restriction of the Use of Hazardous Substances in Electrical and Electronic Products.

Standards, machinery and electrical equipment

Standard requirements fulfilled by this product are summarized in the table below.

Standard	Description
EN ISO 12100	Safety of machinery. General principles for design. Risk assessment and risk reduction.
EN 61010-1, IEC 61010-1, UL 61010-1, CAN/CSA-C22.2 No. 61010-1	Safety requirements for electrical equipment for measurement, control, and laboratory use - Part 1: General requirements.

- 1 Introduction
- 1.3 Regulatory information
- 1.3.4 Other regulations and standards

Standard	Description
EN 61326-1	<p>Electrical Equipment for Measurement, Control, and Laboratory Use-EMC requirements-Part 1: General requirements (Emission according to CISPR 11, Group 1, class A)</p> <div data-bbox="568 442 1117 720" style="border: 1px solid black; padding: 10px;">  <p>NOTICE This equipment is not intended for use in residential environments and may not provide adequate protection to radio reception in such environments.</p> </div>

Regulatory compliance of connected equipment

Any electrical equipment connected to ÄKTA start should meet the safety requirements of EN/IEC 61010-1, or relevant national safety regulations and standards. Within EU, connected equipment must be CE marked.



NOTICE
Any computer used with the equipment shall comply with EN/IEC 60950-1, and be installed and used according to the manufacturer's instructions.

1.4 Associated documentation

Introduction

This section describes the user documentation that is delivered with the instrument and how to find related literature that can be downloaded or ordered from GE.

User documentation on the CD

The user documentation listed in the table below is available on the ÄKTA start User Documentation CD.

Documentation	Main contents
<i>ÄKTA start Operating Instructions</i>	Instructions needed to install, operate and maintain ÄKTA start in a safe way.
<i>ÄKTA start Maintenance Manual</i>	Detailed instructions for maintenance and troubleshooting of ÄKTA start.
ÄKTA start Unpacking Instructions	Instructions for unpacking ÄKTA start.
ÄKTA start UV module and Support Information	Instructions for initial setup of the UV monitor.
<i>ÄKTA start System Cue Card</i>	A condensed guide to prepare and run chromatographic techniques on ÄKTA start.
<i>ÄKTA start Maintenance Cue Card</i>	A condensed guide to handling routine maintenance operations and troubleshooting ÄKTA start.

The following documentation is available from the Instrument Display.

Documentation	Main contents
<i>ÄKTA start Instrument Display Help</i>	Dialog descriptions of the functionality menu for ÄKTA start (only accessible from the Instrument Display).

1 Introduction

1.4 Associated documentation

From the Help menu in UNICORN start or on the UNICORN start DVD, the following user documentation is available.

Documentation	Main contents
<i>UNICORN start User Manual</i>	Overview and detailed descriptions of the system control software designed for ÄKTA start, which includes process picture map for real time monitoring, method editor, evaluation and administration modules.
<i>UNICORN start Online Help</i>	Dialog descriptions for UNICORN start (only accessible from the Help menu).

Data files, application notes and user documentation on the web

To order or download data files, application notes or user documentation, see the instruction below.

Step	Action
1	Go to www.gelifesciences.com/AKTASTart .
2	Navigate to Related Documents under Product Support .
3	Select to download the chosen literature.

Access documentation from mobile units

Scan the code using your mobile phone or tablet computer to access the product page for ÄKTA start. Select documents to download from **Related Documents** under **Product Support**.



1.5 Abbreviations

Introduction

This section explains abbreviations that appear in the user documentation for ÄKTA start.

Abbreviations

Abbreviation	Definition
AC	affinity chromatography
AU	absorbance unit
BMP	bitmap file format
cP	centipoise (unit of viscosity)
CV	column volume
DM	demineralized
DS	desalting
ETFE	ethylene tetrafluoroethylene
FEP	fluorinated ethylene propylene
FPGA	field-programmable gate array
GF	gel filtration (synonymous with size exclusion chromatography)
IEX	ion exchange chromatography
LED	light-emitting diode
mS	milliSiemens (unit of conductivity)
PEEK	polyether ether ketone
RBS	proprietary detergent
SEC	size-exclusion chromatography (synonymous with gel filtration)
UNF	unified fine thread (screw thread standard)
UPS	uninterruptible power supply
USB	universal serial bus

2 Safety instructions

About this chapter

This chapter describes safety precautions and emergency shutdown procedures for the product. The labels on the system and recycling procedures are also described.

In this chapter

This chapter contains the following sections:

Section	See page
2.1 Safety precautions	22
2.2 Labels	30
2.3 Emergency procedures	34
2.4 Recycling procedures	36
2.5 Declaration of Hazardous Substances (DoHS)	37

2.1 Safety precautions

Introduction

ÄKTA start is powered by mains voltage and handles liquids that may be hazardous. Before installing, operating or maintaining the system, you must be aware of the hazards described in this manual. **Follow the instructions provided to avoid personal injuries or damage to the equipment.**

The safety precautions in this section are grouped into the following categories:

- General precautions
 - Using flammable liquids
 - Personal protection
 - Installing and moving the instrument
 - System operation
 - Maintenance
-

General precautions



WARNING

Always follow these General precautions to avoid injury when using ÄKTA start.

- Do not operate ÄKTA start in any other way than described in the ÄKTA start user documentation.
- Operation and user maintenance of ÄKTA start should be performed according to the instructions described in *ÄKTA start Operating Instructions* and *ÄKTA start Maintenance Manual*.
- Do not use any accessories not supplied or recommended by GE.
- Do not use ÄKTA start if it is not working properly, or if it has suffered any damage, for example:
 - damage to the power cord, its plug or the Frac30 cable
 - damage caused by dropping the equipment
 - damage caused by splashing liquid onto it

Flammable liquids and explosive environment



WARNING

When using flammable liquids with ÄKTA start, follow these precautions to avoid any risk of fire or explosion.

- **Fire Hazard.** Before starting the system, make sure that there is no unintentional leakage in the instrument or tubing.
- **Explosion hazard.** To avoid building up an explosive atmosphere when using flammable liquids, make sure that the room ventilation meets the local requirements.



WARNING

Explosive environment. The products are **not approved** for work in a potentially explosive atmosphere. The products do not fulfill the requirements of the ATEX Directive.



CAUTION

ÄKTA start is filled with 24% ethanol at delivery. **The alcohol can be hazardous to humans if consumed.** Flush out the alcohol before assembling, testing or integrating ÄKTA start into the intended process context.

Personal protection



WARNING

To avoid hazardous situations when working with ÄKTA start, take the following measures for personal protection.

Spread of biological agents. The operator has to take all necessary actions to avoid spreading hazardous biological agents in the vicinity of the equipment. The facility should comply with the national code of practice for biosafety.

2 Safety instructions

2.1 Safety precautions



CAUTION

To avoid hazardous situations when working with ÄKTA start, take the following measures for personal protection.

- Always use appropriate personal protective equipment during operation and maintenance of ÄKTA start.
- **Spillage hazard.** When using ÄKTA start use personal protective equipment like goggles, lab coat, protective shoes and gloves to avoid any circumstances of spillage.
- **Cut injuries.** The tubing cutter is very sharp and must be handled with care to avoid injuries.
- **Hazardous substances.** When using hazardous chemical and biological agents, take all suitable protective measures, such as wearing protective glasses and gloves resistant to the substances used. Follow local and/or national regulations for safe operation, maintenance and decommissioning of the equipment.

Installing and moving the instrument



WARNING

To avoid damage to person when installing or moving ÄKTA start, follow the instructions below.

- **Moving the instrument horizontally.** One person is recommended when moving the instrument horizontally.
- **Supply voltage.** Make sure that the supply voltage at the wall outlet corresponds to the marking on the instrument, before connecting the power cord.
- **Power cord.** Only use grounded power cords delivered or approved by GE.
- **Access to power switch and power cord with plug.** Do not block access to the power switch and power cord. The power switch must always be easy to access. The power cord with plug must always be easy to disconnect.
- **Installing the computer (optional).** The computer should be installed and used according to the instructions provided by the manufacturer of the computer.
- **Disconnect power.** Always switch off power to ÄKTA start before an instrument module is removed or installed, or a cable is connected or disconnected.



CAUTION

To avoid damage to person when installing or moving ÄKTA start, follow the instructions below.

Protective ground. ÄKTA start must always be connected to a grounded power outlet.



CAUTION

ÄKTA start is filled with 24% ethanol at delivery. **The alcohol can be hazardous to humans if consumed.** Flush out the alcohol before assembling, testing or integrating ÄKTA start into the intended process context.

2 Safety instructions

2.1 Safety precautions



NOTICE

To avoid damage to ÄKTA start or other equipment when installing or moving the instrument, follow the instructions below.

- **Vents on ÄKTA start.** To ensure adequate ventilation, keep papers and other objects away from the vents of the instrument.
- Any computer used with the equipment shall comply with IEC 60950 and be installed and used according to the manufacturer's instructions.
- Frac30 should not be connected or disconnected from ÄKTA start when the instrument is powered ON.

System operation



WARNING

To avoid personal injury when operating ÄKTA start, follow the instructions below.

- **Rotating the instrument.** Make sure that there is always at least 20 cm of free space around ÄKTA start to allow for sufficient ventilation. When turning or moving the instrument, take care not to stretch or squeeze tubing or cables. A disconnected cable may cause power interruption or network interruption. Stretched tubing may cause bottles to fall, resulting in liquid spillage and shattered glass. Squeezed tubing may cause increase in pressure, or block liquid flow. To avoid the risk of knocking over bottles, always place bottles on the buffer tray and turn or move carefully.
- **Hazardous chemicals during run.** When using hazardous chemicals, run the **System cleaning** template to clean and flush the entire system tubing with distilled water, before service and maintenance.
- **Setting.** Check that the correct outlet size settings are used. Make sure that tubing and fittings are properly connected and secured. Make sure that the pressure limit settings are correct before starting the run.



CAUTION

To avoid personal injury when operating ÄKTA start, follow the instructions below.

- **Max weight on Buffer tray.** Do not place containers with a volume of more than 1 liter each on the Buffer tray. The maximum allowed weight on the Buffer tray is 5 kg.
- **Large spillage.** Switch off ÄKTA start and unplug the power cord, if large spillage occurs.



NOTICE

To avoid damage to ÄKTA start or other equipment when operating the instrument, follow the instructions below.

- **Keep UV flow cell clean.** Do not allow solutions containing dissolved salts, proteins or other solid solutes to dry out in the flow cell. Do not allow particles to enter the flow cell, as damage to the flow cell may occur.
- **Prefill UV flow cell.** Make sure that the **UV flow cell** is prefilled with liquid before starting the system.
- **Avoid condensation.** If ÄKTA start is kept in a cold room, cold cabinet or similar, keep the instrument switched on in order to avoid condensation.
- **Avoid overheating.** If ÄKTA start is kept in a cold cabinet and the cold cabinet is switched off, make sure to switch off the instrument and keep the cold cabinet open to avoid overheating.
- **Place the computer in room temperature.** If ÄKTA start is placed in a cold room, place the computer outside the cold room and use the PC Connectivity cable delivered with the instrument to connect to the computer.
- **Keep the pump cover open when not using the system.** Open the peristaltic pump cover after you switch off the equipment. This will enhance the life time of the pump tubing.

Maintenance



WARNING

To avoid damage to person when performing maintenance on ÄKTA start, follow the instructions below.

- **Electrical shock hazard.** Do not open any covers or parts unless specified in the user documentation. Except for the maintenance and service described in the user documentation, all other repairs should be done by service personnel authorized by GE.
- Only spare parts and accessories that are approved or supplied by GE may be used for maintaining or servicing ÄKTA start.
- **Disconnect power.** Always switch off power to the instrument before replacing any component on the instrument or cleaning the instrument, unless stated otherwise in the user documentation.
- **Spillage Hazard.** Avoid spillage of fluids on the surfaces of the instrument which have cables, plugs and other wirings. Be careful if there is spillage of fluids on the tray while trying to remove the tray from ÄKTA start.
- NaOH is corrosive and therefore dangerous to health. When using hazardous chemicals, avoid spillage and wear protective glasses and other suitable Personal Protective Equipment (PPE).



CAUTION

To avoid damage to person when performing maintenance on ÄKTA start, follow the instructions below.

- **Hazardous UV light.** Always switch off power to the instrument before replacing the **UV flow cell**.
- If hazardous chemicals are used for system or column cleaning, wash the system or columns with a neutral solution in the last phase or step before maintenance.



NOTICE

Cleaning. Keep the instrument dry and clean. Wipe regularly with a soft damp tissue and, if necessary, a mild cleaning agent. Let the instrument dry completely before use.





2.2 Labels

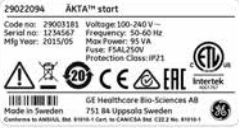

Introduction

This section describes the safety labels and labels concerning hazardous substances that are attached to ÄKTA start. The instrument serial number is also visible from the instrument product label which is illustrated here.

Labels on ÄKTA start





The illustrations below show the labels that are attached to ÄKTA start.

Label	Description	Placement
 <p>29022094 ÄKTA™ start Code no: 29003181 Voltage: 100-240 V ~ Serial no: 1234567 Frequency: 50-60 Hz Mfg Year: 2015/05 Max Power: 95 VA Power: 250W/250V Protection Class: IP21 CE ENEC Intertek GE Healthcare Bio-Sciences AB Made in Sweden 751 84 Uppsala Sweden Conforms to ANSI/AIHA, Inc. H1910-1 Conf. to CAN/CSA Std. C22.2 No. 9500-1</p>	<p>Instrument label including safety symbols and specification.</p>	
<p>La rupture du sceau annule la garantie Warranty void if seal is broken</p>	<p>Do not open any covers on the instrument. This will void the warranty.</p>	
	<p>Keep the pump cover open when not using the system. Open the pump cover after you switch off the instrument.</p>	

Label	Description	Placement
	Warning! Consult the Operating Instructions before using the system.	
	Pinch hazard. Switch off the Pump before loading tubing.	

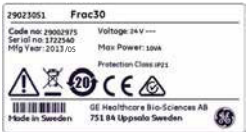

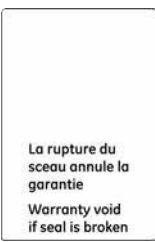



Label on Frac30

The illustration below shows the labels that are attached to Frac30.

Label	Description	Placement
	Instrument label including safety symbols and specification.	
	Do not open any covers on the instrument. This will void the warranty.	

Symbols on the instrument labels

The following symbols are used on the instrument labels:

Label	Meaning
	Warning! Read the user documentation before using the system. Do not open any covers or replace parts unless specifically stated in the user documentation.
	This symbol indicates that the waste of electrical and electronic equipment must not be disposed as unsorted municipal waste and must be collected separately. Please contact an authorized representative of the manufacturer for information concerning the decommissioning of equipment.
	This symbol indicates that the product contains hazardous materials in excess of the limits established by the Chinese standard <i>GB/T 26572 Requirements of concentration limits for certain hazardous substances in electrical and electronic products</i> .
	The system complies with applicable European directives.
	The equipment complies with the requirements for electromagnetic compliance (EMC) in Australia and New Zealand.
	Eurasian Conformity mark: the single conformity mark indicates that the product is approved for circulation on the markets of the member states of the Eurasian Customs Union.
	This symbol indicates that ÄKTA start has been certified by a Nationally Recognized Testing Laboratory (NRTL). This product Conforms to UL 61010-1, and is Certified to CAN/CSA-C22.2 No. 61010-1.
Voltage Frequency Max. Power	Electrical requirements: <ul style="list-style-type: none"> • Voltage (VAC ~) • Frequency (Hz) • Max. power (VA)

Label	Meaning
Protection Class	Degree of protection provided by the enclosure.
Mfg. Year	Year (YYYY) and month (MM) of manufacture

For information regarding shelf life, please contact your local GE representative. For information regarding manufacturing date, see year and month of production on the product.

2.3 Emergency procedures

Introduction

This section describes how to do an emergency shutdown of ÄKTA start. The section also describes the result in the event of power failure.

Emergency shutdown

In an emergency situation:

Switch off power to the instrument by pressing the power switch to the **O** position or by disconnecting the power cord from the instrument. The run is interrupted immediately.





WARNING

Access to power switch and power cord with plug. Do not block access to the power switch and power cord. The power switch must always be easy to access. The power cord with plug must always be easy to disconnect.

Power failure

The result of a power failure depends on which unit is affected.

Power failure to...	will result in...
<p>ÄKTA start</p> 	<ul style="list-style-type: none"> • The run is interrupted immediately. • The data collected up to the time of the power failure is saved in UNICORN start (if the system is connected to a computer), or on the USB memory stick.
<p>UNICORN start on a computer</p> 	<ul style="list-style-type: none"> • The computer with UNICORN start installed shuts down. • On the ÄKTA start Instrument Display, all four touch buttons will be highlighted. • The run is interrupted immediately. • Data generated up to 10 seconds before the power failure can be recovered. <p>Note: <i>The UNICORN start client may close down during a temporary overload of the processor. As long as the run continues, you can restart the UNICORN start client to regain control.</i></p>

2.4 Recycling procedures

Introduction

This section describes the procedures for disposal and recycling of ÄKTA start.

Decontamination

The product must be decontaminated before decommissioning. All local regulations must be followed with regard to scrapping of the equipment.

Disposal of the product

When taking the product out of service, the different materials must be separated and recycled according to national and local environmental regulations.

Disposal of electrical components



Waste electrical and electronic equipment must not be disposed of as unsorted municipal waste and must be collected separately. Please contact an authorized representative of the manufacturer for information concerning the decommissioning of the equipment.

2.5 Declaration of Hazardous Substances (DoHS)

根据SJ/T11364-2014《电子电气产品有害物质限制使用标识要求》特提供如下有关污染控制方面的信息。

The following product pollution control information is provided according to SJ/T11364-2014 Marking for Restriction of Hazardous Substances caused by electrical and electronic products.

电子信息产品污染控制标志说明 Explanation of Pollution Control Label



该标志表明本产品含有超过中国标准GB/T 26572《电子电气产品中限用物质的限量要求》中限量的有害物质。标志中的数字为本产品的环保使用期，表明本产品在正常使用的条件下，有毒有害物质不会发生外泄或突变，用户使用本产品不会对环境造成严重污染或对其人身、财产造成严重损害的期限。单位为年。

为保证所声明的环保使用期限，应按产品手册中所规定的环境条件和方法进行正常使用，并严格遵守产品维修手册中规定的定期维修和保养要求。

产品中的消耗件和某些零部件可能有其单独的环保使用期限标志，并且其环保使用期限有可能比整个产品本身的环保使用期限短。应到期按产品维修程序更换那些消耗件和零部件，以保证所声明的整个产品的环保使用期限。

本产品在使用寿命结束时不可作为普通生活垃圾处理，应被单独收集妥善处理。

This symbol indicates the product contains hazardous materials in excess of the limits established by the Chinese standard GB/T 26572 Requirements of concentration limits for certain restricted substances in electrical and electronic products. The number in the symbol is the Environment-friendly Use Period (EFUP), which indicates the period during which the hazardous substances contained in electrical and electronic products will not leak or mutate under normal operating conditions so that the use of such electrical and electronic products will not result in any severe environmental pollution, any bodily injury or damage to any assets. The unit of the period is "Year".

In order to maintain the declared EFUP, the product shall be operated normally according to the instructions and environmental conditions as defined in the product manual, and periodic maintenance schedules specified in Product Maintenance Procedures shall be followed strictly.

Consumables or certain parts may have their own label with an EFUP value less than the product. Periodic replacement of those consumables or parts to maintain the declared EFUP shall be done in accordance with the Product Maintenance Procedures.

This product must not be disposed of as unsorted municipal waste, and must be collected separately and handled properly after decommissioning.

2 Safety instructions

2.5 Declaration of Hazardous Substances (DoHS)

有害物质的名称及含量

Name and Concentration of Hazardous Substances

产品中有害物质的名称及含量

Table of Hazardous Substances' Name and Concentration

部件名称 Component name	有害物质 Hazardous substance					
	铅 Pb	汞 Hg	镉 Cd	六价铬 (Cr(VI))	多溴联苯 PBB	多溴二苯醚 PBDE
29022094	X	0	0	0	0	0
29023051	X	0	0	0	0	0

本表格依据SJ/T 11364的规定编制。

This table is prepared according to SJ/T 11364.

- 0: 表示该有害物质在该部件所有均质材料中的含量均在GB/T 26572规定的限量要求以下。
- X: 表示该有害物质至少在该部件的某一均质材料中的含量超出GB/T 26572规定的限量要求。
- 此表所列数据为发布时所能获得的最佳信息。
- 0: Indicates that this hazardous substance contained in all of the homogeneous materials for this part is below the limit requirement in GB/T 26572.
- X: Indicates that this hazardous substance contained in at least one of the homogeneous materials used for this part is above the limit requirement in GB/T 26572.
- Data listed in the table represents best information available at the time of publication.

3 System description

About this chapter

This chapter provides an overview of ÄKTA start, the Instrument Display, that allows the user to operate and control the system, and Frac30 (Fraction collector).

In this chapter

This chapter contains the following sections:

Section	See page
3.1 System overview	40
3.2 Instrument	44
3.3 Instrument Display	47

3 System description

3.1 System overview

3.1 System overview

Introduction

ÄKTA start is operated and controlled from the Instrument Display. In addition, the UNICORN start software can be used to control ÄKTA start and to analyze the data acquired during chromatography runs. UNICORN start offers several additional features that are described in detail in *UNICORN start User Manual*.

This section gives an overview of the ÄKTA start System.

Illustration of the system

The illustration below shows the ÄKTA start System with UNICORN start installed on a computer.



Part	Description
1	ÄKTA start (instrument).
2	Frac30 (Fraction collector).
3	UNICORN start (software installed on a computer).

Illustration of the instrument

The illustration below shows the main parts of the instrument.

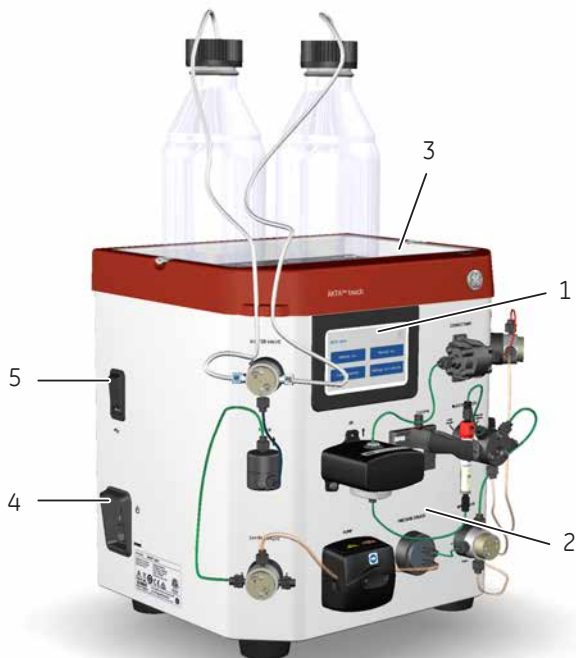

Part	Description	Function
1	Instrument Display	User interface for controlling the system and visualization of the runtime data.
2	Wet side	The modules interconnected by tubing have the following functions: <ul style="list-style-type: none"> to deliver the liquid in a specified flow path and divert the flow as required, to monitor the UV absorbance and conductivity of the liquid.
3	Buffer tray	Location intended for the placement of buffer bottles used during chromatography runs.
4	Power switch	Connects or disconnects the power.

3 System description

3.1 System overview

Part	Description	Function
5	USB port	To connect a USB memory stick for storage of results and transfer of files. Note: <i>USB hard drives are not supported.</i>

Illustration of the Fraction collector

The illustration below shows the Fraction collector (Frac30), showing the front and rear views.

Note: ÄKTA start does not support fractionation with any fraction collector other than Frac30.

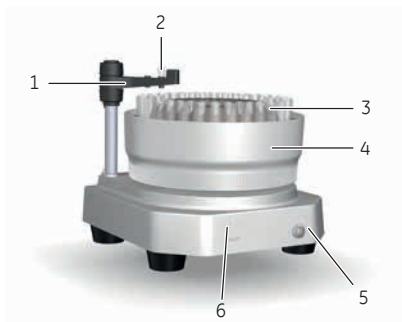

Front side view

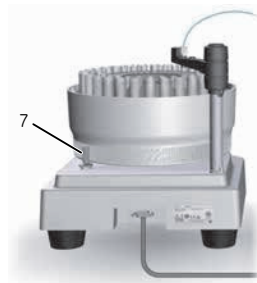

Rear view

Part	Description	Function
1	Dispenser arm assembly	Holds and positions the tubing holder for dispensing the liquid into fractions.
2	Tubing holder	Holds the tubing used for dispensing the liquid fractions into the collection tubes.
3	Collection tubes	10 to 18 mm diameter tubes used to collect the fractions.
4	Bowl assembly	Holder for collection tubes, which supports tubes of four sizes.
5	Base unit	Case for electromechanical assembly and holder for the Bowl assembly.

Part	Description	Function
6	LED	Power on indicator.
7	Drive sleeve	Friction drive to turn the Bowl assembly during fraction collection.

Main features of ÄKTA start

The main features of ÄKTA start are listed below:

- ÄKTA start is a compact and one step purification solution for quick and reliable purification of proteins.
 - A simple and modern system offered to automate the protein purification workflow by providing features like automated sample injection, fraction collection, real-time monitoring.
 - Method templates are available for all common chromatography techniques such as Affinity Chromatography, Ion Exchange Chromatography, Gel filtration, and De-salting.
 - Quick start methods are available for purifying several common proteins.
 - Predefined system methods are available for cleaning the flow path.
 - ÄKTA start is operated using a touch screen on the instrument.
 - In addition, the system can be operated from a computer connected to the instrument using the UNICORN start software.
 - ÄKTA start is offered with a dedicated Fraction collector, Frac30, allowing collection of fractions in four different tube sizes.
-

3.2 Instrument

Introduction

This section provides an overview of ÄKTA start modules.

Illustration of the instrument modules

The illustration below shows the locations and gives brief descriptions of the modules placed on the wet side of the instrument.

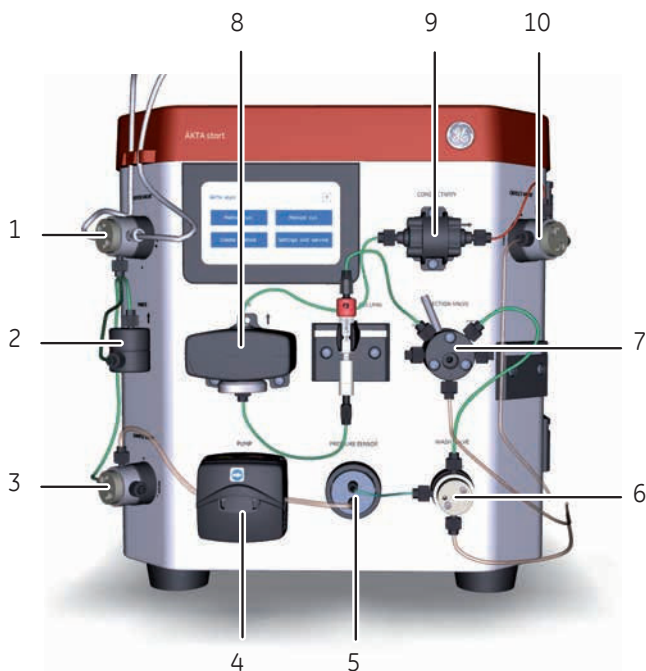

Part	Function	Description
1	Buffer valve	A 3-port valve that is used as a switching valve for gradient formation using two buffers.
2	Mixer	A static mixer that is used for mixing buffers A and B.

Part	Function	Description
3	Sample valve	A 3-port valve that allows either the buffer or the sample to enter the flow path. The Sample valve enables direct application of the sample onto the column using the Pump .
4	Pump	A peristaltic pump, which delivers buffer or sample to the flow path with a flow rate of up to 5 ml/min. For cleaning procedures, the Pump can flush the flow path at a flow rate of 10 ml/min.
5	Pressure sensor	The Pressure sensor reads the pressure in the flow path and senses overpressure.
6	Wash valve	A 3-port valve that is used to divert the flow path to waste. The Wash valve switches automatically during the predefined cleaning procedure, Pump wash . In a manual run, the valve can be set to the intended position by configuring the run parameters.
7	Injection valve	<p>A 6-port manually operated valve that is used to transfer the sample loaded in the sample loop on to the column.</p> <p>A sample loop is connected to the appropriate ports of the valve. The valve is switched manually to positions:</p> <ul style="list-style-type: none"> • Load sample: to allow the loading of the sample into the sample loop. • Inject to column: to transfer the sample from the loop on to the column during a chromatography run.
8	UV	The UV Monitor continuously measures the absorbance of the liquid in the UV flow cell at a fixed wavelength of 280 nm. The UV flow cell has a path length of 2 mm.

3 System description

3.2 Instrument

Part	Function	Description
9	Conductivity	<p>The Conductivity Monitor continuously reads the conductivity of the liquid in the Conductivity flow cell.</p> <p>The conductivity is automatically calculated by multiplying the measured conductance by the cell constant of the flow cell. The cell constant is factory-calibrated.</p> <p>The Conductivity flow cell is provided with a temperature sensor that measures the temperature of the liquid in the Conductivity flow cell.</p> <p>Note: <i>The buffers used should be within the conductivity range of the instrument (0 to 300 mS/cm).</i></p>
10	Outlet valve	A 3-port valve that is used to direct the flow to the Fraction collector or to Waste.

3.3 Instrument Display

Introduction

This section provides a description of the ÄKTA start Instrument Display and the functions that are accessible from the display.

In this section

This section contains the following sub-sections:

Section	See page
3.3.1 Overview of the Instrument Display	48
3.3.2 Description of Method run	53
3.3.3 Description of Create method	56
3.3.4 Description of Settings and service	57

3.3.1 Overview of the Instrument Display

Introduction

The Instrument Display is located on the front side of ÄKTA start. The Instrument Display enables the user to control the system by selecting the intended operation:

- Start a run and control an ongoing run.
- View the progress of the ongoing run.
- Manage user defined methods.
- Perform maintenance and service.

This section provides a brief description of the functions of the Instrument Display.

Note: Do not operate the Instrument Display with a sharp and hard object.

Illustration of the Instrument Display

The illustration below shows the location and detailed view of the Instrument Display.

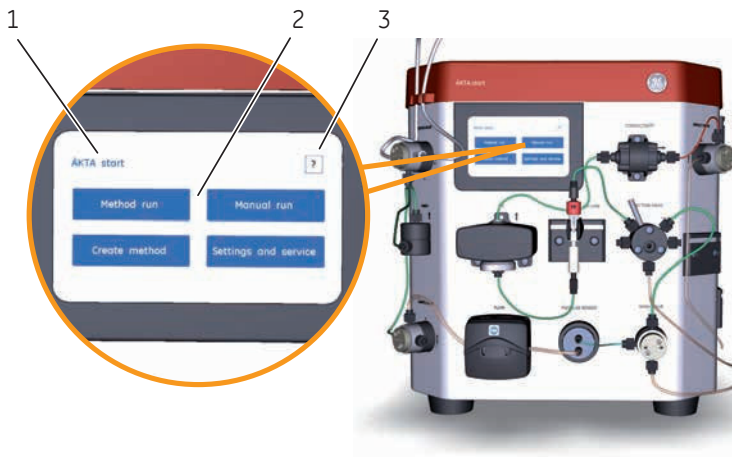

Part	Description
1	Screen name area.
2	Information area. The example shows the ÄKTA start home screen.
3	Help button.





Instrument software

ÄKTA start offers the following functionality menu, displayed on the **ÄKTA start** home screen as presented in the table below. For detailed workflows on the different options, see *Chapter 6 Operation from the Instrument Display, on page 142*.

Option	Description
Method run	Use a quick start or a method template to perform a run.
Manual run	Perform a run by providing parameters manually.
Create method	Create, edit, import and delete user methods.
Settings and service	Configure settings and calibrate modules, perform diagnostics tests.

Description of buttons on the Instrument Display











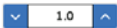
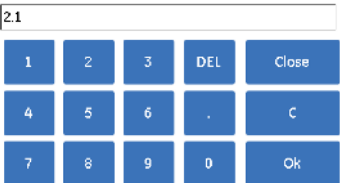

The Instrument Display includes the following touch buttons:









Button	Name	Description
	Help	Opens a new dialog screen, providing information about the content of the current screen or indicates where further information or instructions can be found.
	Home	Opens the ÄKTA start home screen.
	Forward	Opens the next screen in the current workflow.
	Return	Opens the previous screen in the current workflow.

3 System description

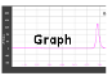
3.3 Instrument Display

3.3.1 Overview of the Instrument Display

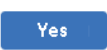
Button	Name	Description
	Increment (up arrow) Decrement (down arrow)	The value in the text field can be increased or decreased by tapping up or down arrow. Tapping the value opens the numpad and a new value can be typed in.  Note: <i>After typing in a value on the numpad, tap OK to confirm the new value.</i>
	Next	Opens the next screen.
	Back	Returns to the previous screen.
	Run	Starts a run.
	Pause	Pauses the ongoing run by stopping the Pump . The flow rate settings and the gradient values are retained.
	Continue	Continues a run that has been paused.
	Hold	Holds an ongoing run, with current flow rate, valve positions, and with set %B concentration. The gradient is held at the value displayed.
	Resume	Resumes a run that is put on hold.
	Edit run	Opens a new screen for editing the current run parameters.
	Execute	Executes the edited run parameters during a run.
	OK	Confirms a selection or an action.
	Cancel	Cancels a selection or an action.

Button	Name	Description
	End	Terminates the ongoing run; always followed by a screen that requires confirmation of the action.
	Exit	When a run is completed, it closes the application and returns to the ÅKTA start home screen.
	Graph icon	Opens the graphic view of the run in progress, displaying the plot of the UV absorbance (mAU) versus Time (min).
	Save	Saves a user method that was either created or edited.
	Select	Confirms and initiates a run from a specific template or user method.
	Create	Creates a user method based on selected template. The run parameters have to be edited as needed.
	Yes	Confirms an action.
	No	Rejects an action.

Description of Instrument Display Help

The *ÄKTA start Instrument Display Help* is accessible from every screen on the Instrument Display, by tapping the question mark in the upper right corner. The *Help text* provides information about the content of the current screen or refers to more detailed documentation.



3.3.2 Description of Method run

Method run options



The display option **Method run** allows the user to run methods based on **Quick start** techniques or predefined method templates, user created methods, and predefined methods such as **Pump Wash**, and **System cleaning**. Detailed instructions for running methods are presented in *Section 6.4 Perform a method run, on page 158*.

When **Method run** is selected, further options are displayed in the **Method run** screen.



The method types available under **Method run** are briefly described below.

Method	Description
<p>Quick start (1/3)</p>	<p>Displays the Quick start templates available with ÄKTA start.</p> <p>For description of the Quick start methods, see <i>Section 6.4.2 Quick start, on page 161</i>.</p>
<p>Quick start (2/3)</p>	

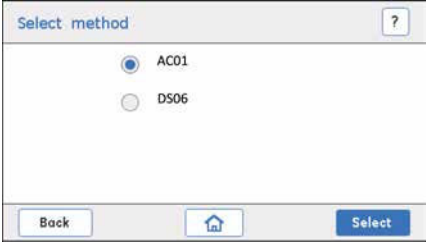
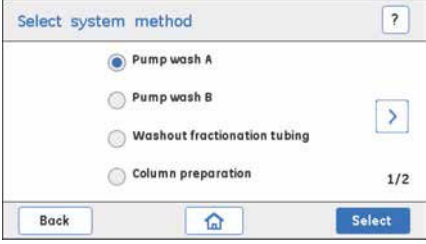
Method	Description
<p>Quick start (3/3)</p> 	
<p>Templates</p> 	<p>Displays the method templates for chromatography techniques available with ÄKTA start.</p> <p>For a description of the templates, see <i>Section 6.4.3 Templates, on page 167</i>.</p>
<p>User defined</p> 	<p>Displays the methods created by the user.</p> <p>For detailed instructions on creating and managing user defined methods, see <i>Section 6.6 Manage methods and files, on page 183</i>.</p>
<p>Prepare system (1/2)</p> 	<p>Displays the predefined system methods that are used to clean the system flow path.</p> <p>For detailed instructions on running system methods, see <i>Section 6.4.5 Prepare system methods, on page 177</i>.</p>

Method	Description
<p>Prepare system (2/2)</p> <div data-bbox="349 329 775 569"><p>Select system method ?</p><p><input checked="" type="radio"/> System cleaning</p><p><input type="radio"/> System performance method</p><p><</p><p>2/2</p><p>Back Home Select</p></div>	

3.3.3 Description of Create method

Create method options

The display option **Create method** allows the user to create new methods, edit or delete existing user methods and also import methods stored on a USB memory stick connected to the instrument.

When **Create method** is selected, further options are displayed in the **Create method** screen.

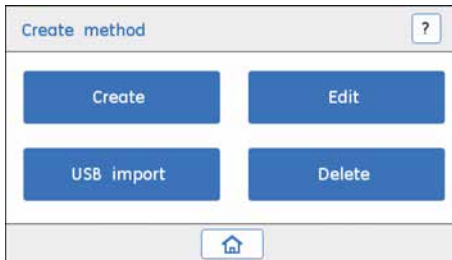

The operations available under **Create method** are briefly described below.



Option	Description
Create	Displays the method templates that can be used to create a new method.
Edit	Displays the user methods stored on the instrument that can be edited, if required.
USB Import	Displays a list of user methods stored on a USB memory stick that can be imported to the instrument.
Delete	Displays the user methods stored on the instrument that can be deleted, if required.

3.3.4 Description of Settings and service

Settings and service options

The display option **Settings and service** allows the user to set the delay volume and perform maintenance, calibration, diagnostics, and troubleshooting of the modules on the wet side of the instrument. For a brief description of the modules, see *Section 3.2 Instrument, on page 44*. Detailed instructions for calibrating the **Pump**, the monitors, and the Instrument Display are presented in the *ÄKTA start Maintenance Manual*.

The options available under **Settings and service** are listed in the table below. For further details, see the *ÄKTA start Maintenance Manual*.

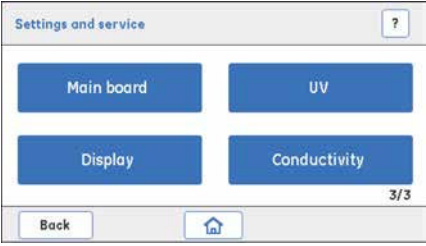
Option	Function
<p>Settings and service - Screen 1</p> 	<p>Allows the user to set the delay volume, and perform calibration, diagnostics, and/or troubleshooting. The menu covers the following modules:</p> <ul style="list-style-type: none"> • Fraction collector • Pressure sensor • Pump • System
<p>Settings and service - Screen 2</p> 	<p>Allows the user to perform diagnostics and/or troubleshooting for the modules:</p> <ul style="list-style-type: none"> • Buffer valve • Sample valve • Wash valve • Outlet valve
<p>Settings and service - Screen 3</p> 	<p>Allows the user to perform calibration, diagnostics, configuration and/or troubleshooting for the modules:</p> <ul style="list-style-type: none"> • Main board • UV • Display • Conductivity

Settings and service - Screen 1

The options available for the modules displayed on **Settings and service** Screen 1 are briefly described below.

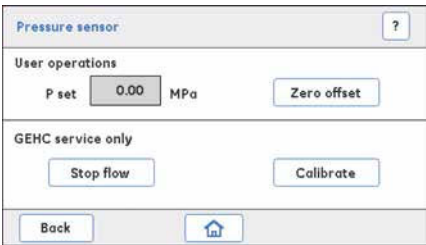
Module	Function
<p>Fraction collector</p> 	<p>Enable Frac/Disable Frac: Activates/Deactivates the Fraction collector connection.</p> <p>Diagnostics: Performs a feed tube test that checks if the Bowl assembly rotates correctly. Performs a Home test to verify that the Bowl assembly returns to Home position.</p> <p>Run log: Shows the number of hours the Frac drive has been active and allows the number of hours of drive usage to be reset.</p>
<p>Pressure sensor</p> 	<p>P set: Shows the pressure in the flow path.</p> <p>Zero offset: Sets the pressure reading to zero. The Pump has to be off and the flow path connection to the Pressure sensor has to be open.</p> <p>Note: <i>Pressure Calibration is performed by a GE Service Engineer only, after the Pressure sensor is replaced.</i></p>

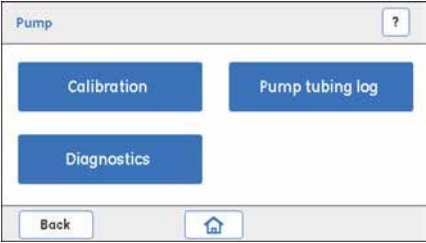
Module	Function
<p>Pump</p> 	<p>Calibration: Calibrates the Pump, so that it delivers liquid with an accurate flow rate.</p> <p>Pump tubing log:</p> <ul style="list-style-type: none"> Shows the number of hours the pump tubing has been in use (Tubing run) and allows the tubing usage count to be reset (after the pump tubing is replaced). Shows the number of hours the Pump has been in use (Pump run) and allows the Pump usage count to be reset (after the Pump is replaced). <p>Diagnostics: Adjusts the flow rate and start/stop the flow (Pump).</p>

3 System description

3.3 Instrument Display

3.3.4 Description of Settings and service

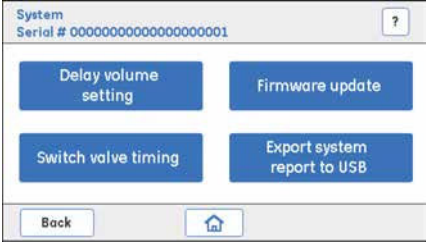
Module	Function
<p>System</p>  <p>System Serial # 00000000000000000001</p> <p>Delay volume setting Firmware update</p> <p>Switch valve timing Export system report to USB</p> <p>Back Home</p>	<p>Delay volume setting: Sets the delay volume. The delay volume represents the volume of the liquid in the flow path between the UV and the collection tubes.</p> <p>Firmware update: Updates the system firmware.</p> <p>Switch valve timing: Sets the Switch valve timing. It is recommended to optimize the timing of switch valve (Buffer valve) when wavy gradients are obtained or when fluctuations in the step gradient are observed during either system performance tests or chromatography runs.</p> <p>Export system report to USB: Exports system error logs to a USB memory stick in a text format. A system error report is useful when trying to understand a possible error that requires remote service support.</p> <p>Note:</p> <p><i>The serial number displayed on the top left of the display screen is the unique identifier for the instrument. The number is also seen as instrument ID when connecting to UNICORN start.</i></p>

Settings and service - Screen 2

The options available for the modules displayed on **Settings and service** Screen 2 are briefly described below.

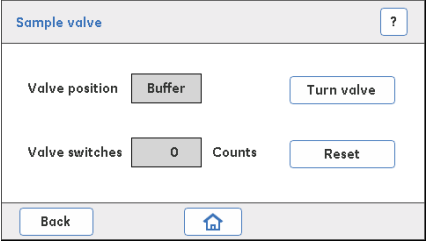
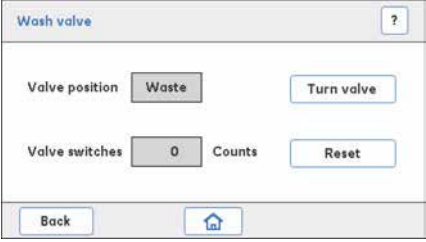
Module	Function
<p>Buffer valve</p> 	<p>Valve position: Shows which inlet connection in the valve is open, Buffer A or Buffer B.</p> <p>Turn valve: Switches the valve between its two positions i.e., the A and B inlet ports.</p> <p>Valve switches: Displays the number of counts the valve has switched.</p> <p>Reset: Resets the counts to zero when a valve has been replaced.</p>
<p>Sample valve</p> 	<p>Valve position: Shows which inlet connection in the valve is open, Buffer or Sample.</p> <p>Turn valve: Switches the valve between its two positions i.e., the Buffer and Sample inlet ports.</p> <p>Valve switches: Displays the number of counts the valve has switched.</p> <p>Reset: Resets the counts to zero when a valve has been replaced.</p>
<p>Wash valve</p> 	<p>Valve position: Shows which outlet connection in the valve is open, Waste or Column.</p> <p>Turn valve: Switches the valve between its two positions i.e., the Waste and Column outlet ports.</p> <p>Valve switches: Displays the number of counts the valve has switched.</p> <p>Reset: Resets the counts to zero when a valve has been replaced.</p>

3 System description

3.3 Instrument Display

3.3.4 Description of Settings and service

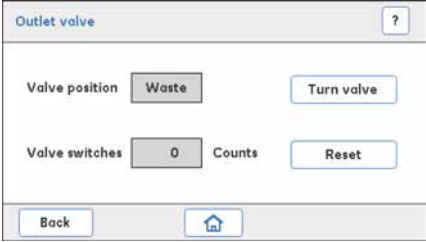
Module	Function
<p>Outlet valve</p> 	<p>Valve position: Shows which outlet connection in the valve is open, Waste or Collection.</p> <p>Turn valve: Switches the valve between its two positions i.e., the Waste and Collection/Frac outlet ports.</p> <p>Valve switches: Displays the number of counts the valve has switched.</p> <p>Reset: Resets the counts to zero when a valve has been replaced.</p>

Settings and service - Screen 3

The options available for the modules displayed on **Settings and service** Screen 3 are briefly described below.

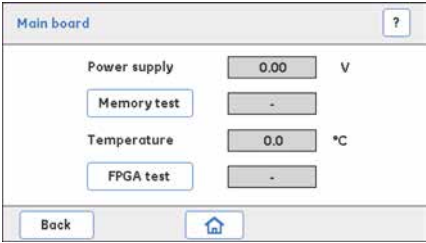
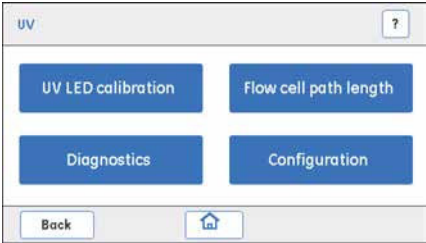
Module	Function
<p>Main board</p> 	<p>Power supply: Shows the actual voltage.</p> <p>Memory test: Performs a memory test.</p> <p>Temperature: Shows the temperature of the main board.</p> <p>FPGA test: Performs a test of the FPGA hardware.</p>
<p>UV</p> 	<p>UV LED calibration: Calibrates the UV LED intensity.</p> <p>Flow cell path length: Derives the actual path length of the flow cell.</p> <p>Diagnostics: Troubleshoots the UV module.</p> <p>Configuration: Configures a new UV monitor and flow cell.</p> <p>Note: <i>UV Configuration is performed by a GE Service Engineer only.</i></p>

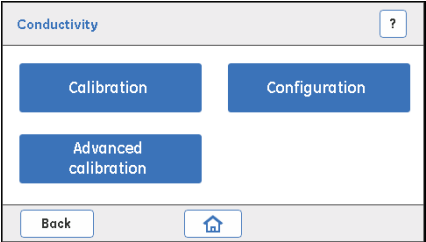
Module	Function
<p>Display</p> 	<p>Touch screen calibration: Calibrates the touch screen.</p> <p>Color test: Performs a diagnostics test for the colors displayed on the touch screen.</p> <p>Diagnostics: Performs a diagnostics test to check the backlight performance of the display.</p> <p>Log book: Shows the number of hours the instrument display has been in use.</p>
<p>Conductivity</p> 	<p>Calibration: Calibrates the Conductivity flow cell and the temperature sensor.</p> <p>Configuration: Sets a new reference temperature value, usually after replacement of the Conductivity flow cell.</p> <p>Advanced calibration: Calibrates the temperature of the Conductivity flow cell.</p>

4 Installation

About this chapter

This chapter provides the necessary instructions to enable users to unpack and install ÄKTA start and Frac30. Read the entire *Installation* chapter before starting to install ÄKTA start.

In this chapter

This chapter contains the following sections:

Section	See page
4.1 Space requirements	65
4.2 Transport ÄKTA start and Frac30	67
4.3 Unpack ÄKTA start and Frac30	69
4.4 Accessories package	79
4.5 Install ÄKTA start	80

4.1 Space requirements

Benchtop setup

The illustration below shows the minimum recommended space for ÄKTA start.



Equipment dimensions

ÄKTA start

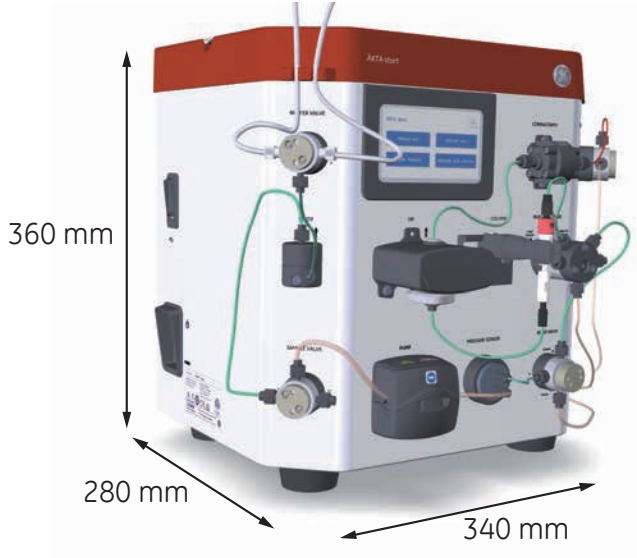

Frac30



4.2 Transport ÄKTA start and Frac30

Equipment weight

Item	Weight
ÄKTA start (with packaging)	12 kg
Frac30 (with packaging)	6 kg

Handling the delivery boxes

ÄKTA start and Frac30 are packed in two separate boxes.



To transport the delivery boxes containing the instrument and Fraction collector, use a hand truck suitable for light weight packages. However, each box can be lifted by 1 person without the help of any lifting equipment.

4 Installation

4.2 Transport ÄKTA start and Frac30



4.3 Unpack ÄKTA start and Frac30

Introduction

This section describes how to unpack ÄKTA start and Frac30.

Note: *Save all the original packing material. If the system has to be repacked, for transportation or otherwise, it is important that the system can be safely packed using the original packing material.*

Unpack ÄKTA start

Follow the instructions below to unpack the instrument.



CAUTION

ÄKTA start is filled with 24% ethanol at delivery. **The alcohol can be hazardous to humans if consumed.** Flush out the alcohol before assembling, testing or integrating ÄKTA start into the intended process context.

Note: *ÄKTA start with packaging weighs about 12 kg. No lifting equipment required, **one** person can lift and move the instrument.*

Step Action

- 1 Open the delivery box by cutting the adhesive tape at the top of the box.



4 Installation

4.3 Unpack ÄKTA start and Frac30

Step	Action
------	--------

- | | |
|---|---|
| 2 | Take out the document placed at the top of the package and read the <i>Unpacking Instructions</i> . |
|---|---|

Note:

Save the documents for future reference.



- | | |
|---|--|
| 3 | Take out the box placed at the top of the package. The box contains the accessories delivered with the instrument. |
|---|--|



Step	Action
------	--------

- | | |
|---|---|
| 4 | Hold the red strap, and then lift the instrument out of the delivery box. |
|---|---|



- | | |
|---|---|
| 5 | Open the strap lock and remove the strap. |
|---|---|



4 Installation

4.3 Unpack ÄKTA start and Frac30

Step	Action
------	--------

- | | |
|---|---|
| 6 | Remove the foam cushion from the top of the instrument. |
|---|---|



- | | |
|---|--|
| 7 | Remove the foam cushion from the bottom of the instrument by carefully lifting the instrument. |
|---|--|



Step	Action
8	Remove the plastic bag by gently tilting the system back and forth while pulling out of the plastic bag.



Unpack Frac30

Follow the instructions below to unpack the Fraction collector.



NOTICE

Take care not to damage the Dispenser arm when lifting Frac30 or when removing the plastic bag. Never lift the Frac30 by the Dispenser arm. This may damage the Fraction collector.

Note: *Frac30 with packaging weighs about 6 kg. No lifting equipment required, one person can lift and move the Fraction collector.*

4 Installation

4.3 Unpack ÄKTA start and Frac30

- | Step | Action |
|------|--|
| 1 | Open the Frac30 delivery box by cutting the adhesive tape at the top of the box. |



- 2 Take out the document placed at the top of the package and read the *Unpacking Instructions*.
- 3 Holding the red strap, lift the fraction collector out of the delivery box. Place the Fraction collector on the laboratory bench.



Step	Action
------	--------

- | | |
|---|---|
| 4 | Open the strap lock and remove the strap. |
|---|---|



- | | |
|---|---|
| 5 | Remove the foam cushion from the top of the Fraction collector. |
|---|---|



4 Installation

4.3 Unpack ÄKTA start and Frac30

Step	Action
------	--------

- | | |
|---|--|
| 6 | Remove the foam cushion from the bottom of the fraction collector by carefully lifting the Fraction collector. |
|---|--|



- | | |
|---|-------------------------|
| 7 | Remove the plastic bag. |
|---|-------------------------|



Step	Action
8	<p>Remove the Bowl assembly from the Base unit:</p> <ul style="list-style-type: none">• Gently move the Dispenser arm counterclockwise to the end position.• Pull the Drive assembly outwards and hold it at the retracted position. At the same time, lift the Bowl assembly.



9	<p>Remove the foam cushion located on the Base unit.</p>
---	--



4 Installation

4.3 Unpack ÄKTA start and Frac30

Step	Action
------	--------

- | | |
|----|--|
| 10 | Re-assemble the Bowl assembly on to the Base unit: <ul style="list-style-type: none">• Orient the Bowl to match the aligning groove and the aligning features located on the bowl holder.• Slightly push the Drive assembly laterally and lower the Bowl assembly onto the Base unit. |
|----|--|



NOTICE

Never use the Dispenser arm assembly to lift or hold Frac30. To lift the module, use the handle provided on the bottom plate.

Note: Do not damage or break the warranty seal label during unpacking of Frac30.



4.4 Accessories package

Illustration of the accessories package

The illustration below shows the accessories box and the user documentation included with ÄKTA start at delivery.

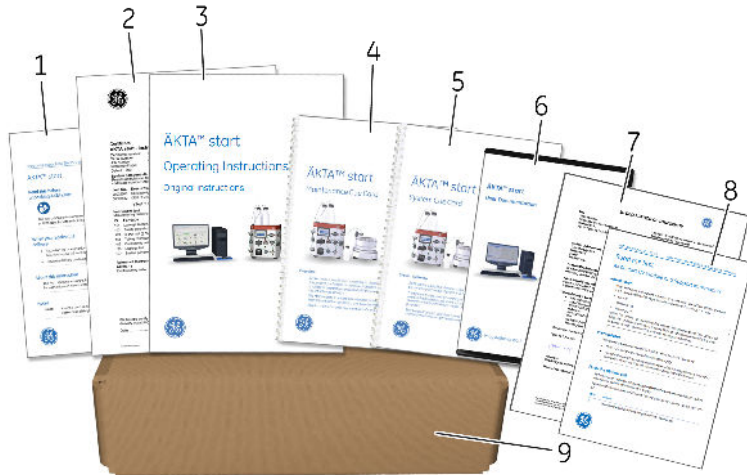

Part	Description
1	Unpacking Instructions
2	System certificate
3	Operating Instructions
4	Maintenance Cue Card
5	System Cue Card
6	CD containing user documentation files The CD includes <i>Operating Instructions</i> and <i>Maintenance Manual</i> in English and translated versions.
7	EU Declaration Of Conformity
8	Instructions: ÄKTA start UV Module and Support Information
9	Accessories box

4.5 Install ÄKTA start

Introduction

This section describes how to install ÄKTA start. The following actions must be performed:

- Install pump tubing.
- Connect power supply to ÄKTA start.
- Connect Frac30 to ÄKTA start.
- Perform initial setup of the **UV** monitor if required, as described in the *ÄKTA start UV Module and Support Information*.
- (Optional) Connect ÄKTA start to the UNICORN start computer.



WARNING

Only use grounded power cords delivered or approved by GE.



WARNING

Supply voltage. Make sure that the supply voltage at the wall outlet corresponds to the marking on the instrument, before connecting the power cord.



CAUTION

Protective ground. ÄKTA start must always be connected to a grounded power outlet.

Install pump tubing

Follow the instructions below to install the pump tubing.

Step	Action
------	--------

- | | |
|---|---------------------------|
| 1 | Open the top cover fully. |
|---|---------------------------|



- | | |
|---|--|
| 2 | Place the tubing between the rollers and the track, press the tubing against the pump head inner wall. |
|---|--|



Note:

Make sure that the pump tubing is not twisted or stretched against the rollers.

4 Installation

4.5 Install ÄKTA start

Step	Action
3	Lower the top cover until it clicks into its fully closed position. The track closes automatically and the tubing is stretched correctly as the track closes.



Connect power to ÄKTA start

Follow the instructions below to connect power to ÄKTA start.

Step	Action
1	Select the correct power cord to be used. ÄKTA start is delivered with 2 alternative power cords: <ul style="list-style-type: none">• Power cord with US-plug, 2 m.• Power cord with EU-plug, 2 m.

Note:

Discard the unused power cord.

Step	Action
2	Connect the power cord to the Power input connector on the left side of the instrument and to a grounded wall outlet 100-240 VAC, 50/60 Hz.



Connect Frac30 to ÄKTA start



NOTICE

Frac30 should not be connected or disconnected from ÄKTA start when the instrument is powered ON.

Follow the instructions below to connect Frac30 to ÄKTA start.

Step **Action**

- 1 Connect the Frac30 cable between the ports on the back of the Fraction collector and the instrument.

Note:

*The supply voltage for Frac30 is distributed from ÄKTA start.
When the Frac30 cable is connected, the screws attached to the connector should be tightened.*



- 2 Switch on ÄKTA start.
- 3 Enable the connection to Frac30 from the Instrument Display:
 - In the **ÄKTA start** home screen, tap **Settings and service**.
*Result: The **Settings and service** Screen 1 opens.*



Step **Action**

- In the **Settings and service** screen, tap **Fraction collector**.

Result: The **Fraction collector** screen opens.

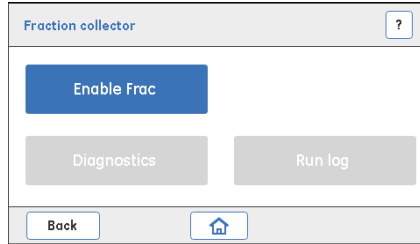

- In the **Fraction collector** screen, tap **Enable Frac** to enable the connection of the Fraction collector.

Result: The following screen will be displayed.



Note:

The power on status of the Fraction collector is indicated by the white LED on the front of Frac30.

Connect a computer to ÄKTA start

Note: *Before connecting the computer to ÄKTA start, install the UNICORN start software on the computer. Refer to the UNICORN start User Manual.*

Follow the instructions below to connect a UNICORN start computer to ÄKTA start.

Step	Action
------	--------

- | | |
|---|--|
| 1 | Connect power to the computer and monitor, and then switch on the computer and ÄKTA start. |
|---|--|

Result: The instrument displays the **ÄKTA start** home screen.

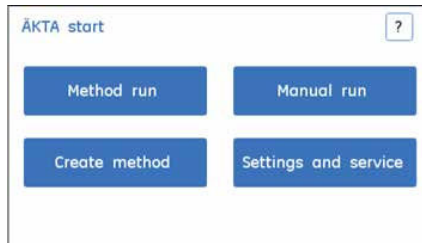

- | | |
|---|--|
| 2 | Connect the PC Connection Cable between the connector marked as PC Connection on the back of ÄKTA start and a USB port on the computer. |
|---|--|



- | Step | Action |
|------|--|
| 3 | <p>Launch UNICORN start and connect to ÄKTA start. For detailed instructions, refer to <i>UNICORN start User Manual</i>.</p> <p><i>Result:</i> The instrument displays the ÄKTA start home screen in connected state.</p> |



Note:

Make sure that the system connection is established before starting the run. Always make sure to be in the **ÄKTA start** home screen (connected state) when trying to connect from the **System Control** module.

5 Prepare the system for a run

About this chapter

This chapter describes how to start the instrument and prepare the system for a run.

In this chapter

This chapter contains the following sections:

Section	See page
5.1 Flow path overview	89
5.2 Start the instrument	92
5.3 Calibration guidelines	93
5.4 System performance	95
5.5 Connect a column	109
5.6 System methods for run preparation	113
5.7 Sample application	123
5.8 Prepare the Fraction collector	134
5.9 Operation in a cold room	138
5.10 Starting a run	140

5.1 Flow path overview

Illustration of the flow path

The illustration below shows the flow path for ÄKTA start. The flow path contains **Pump**, **Mixer**, **Valves**, and **UV**, **Conductivity** and **Pressure** monitors. The individual instrument modules are presented in the table below. For a detailed description of the modules, see the *ÄKTA start Maintenance Manual*.

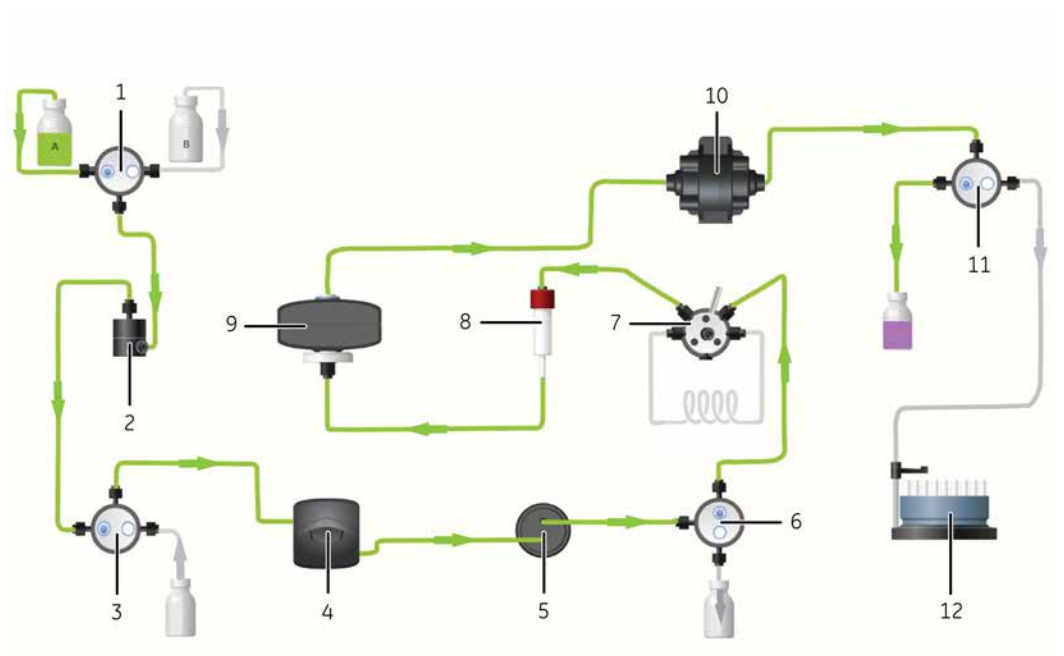

Part	Description	Part	Description
1	Buffer valve	7	Injection valve (manual)
2	Mixer	8	Column
3	Sample valve	9	UV Monitor
4	Pump	10	Conductivity Monitor
5	Pressure sensor	11	Outlet valve
6	Wash valve	12	Fraction collector





5 Prepare the system for a run

5.1 Flow path overview

Inlet and outlet tubing

ÄKTA start is delivered with the entire flow path assembled and pre-filled with storage solution (24% ethanol). Details of the tubing types used along the flow path are presented in *Section 10.1 Specifications, on page 252*.

The table below lists the tubing connected to the instrument. Prepare the system for a run by connecting inlet and outlet tubing to the valve ports marked with orange arrows.

Module	Tube connection	Scope of use
Buffer valve 	Port I (Buffer A)	Inlet tubing for buffer A
	Port II	Outlet tubing to the Mixer .
	Port III (Buffer B)	Inlet tubing for buffer B
Sample valve 	Port I (Sample)	Inlet tubing used when the sample is applied via the Pump .
	Port II	Outlet tubing to the Pump .
	Port III	Inlet tubing from the Mixer .
Wash valve 	Port I (Waste)	Outlet tubing used when cleaning the flow path or changing the buffer by running the Pump Wash A/B template.
	Port II	Inlet tubing from the Pressure sensor .
	Port III	Outlet tubing to the Injection valve
Injection valve 	Port 1	Outlet tubing connected to the column.
	Ports 2 and 5	Inlet/outlet for connecting the sample loop.
	Port 3	Inlet for injecting the sample into the loop.
	Port 4 (Waste)	Outlet tubing to waste, helps in washing or draining excess sample from the loop.
	Port 6	Inlet; the tubing is connected to Wash valve .
Outlet valve 	Port I (Waste)	Outlet tubing to waste.
	Port II	Inlet tubing from the Conductivity Monitor .
	Port III (Collection)	Outlet tubing to the Fraction collector.

Placement of buffer bottles

Buffer bottles are placed in the Buffer tray on top of the instrument, as illustrated below. Sample bottle or tube may be placed on the bench on the left side of the instrument. A waste bottle may be placed on the bench on the right side of the instrument.



CAUTION

Max. weight on Buffer tray. Do not place bottles with a volume of more than 1 liter each on the Buffer tray. The total allowed weight on the Buffer tray is 5 kg.



CAUTION

Avoid spillage and overflow. Make sure that the waste tubing is inserted in an appropriate waste container and secured in place.

Clean the flow path

Before using the system for the first time, clean the flow path as described in *Section 8.3 Cleaning the system flow path, on page 210.*

5.2 Start the instrument

Switch on the instrument

Follow the instruction below to start the instrument.

Step	Action
1	Switch on the instrument by pressing the Power switch to the I position.

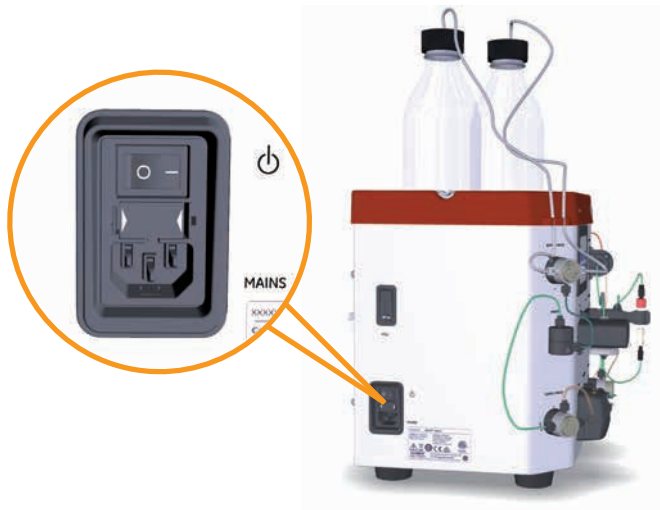

Result: The instrument starts and initializes the display, showing the **ÄKTA start** home screen.

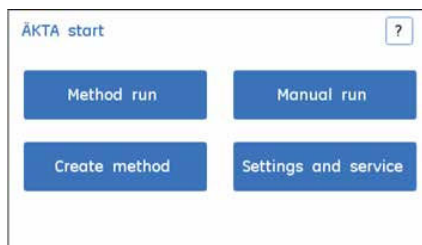

2	You can start using the instrument immediately. All modules are pre-calibrated from the factory.
---	--

5.3 Calibration guidelines

Introduction

For best results, some modules may need calibrating before a run is performed. This section provides guidelines for when calibration should be performed. For details of calibration procedures, refer to the *ÅKTA start Maintenance Manual*.

When to calibrate

Note: *The instrument is pre-calibrated at delivery, therefore no calibration is required when the instrument is installed. However, if the **System performance test** fails it is recommended to calibrate the modules.*

The table below provides recommendations for when modules should be calibrated.

Module	When to calibrate
Instrument Display	<ul style="list-style-type: none"> If there are any issues with the response of the touch screen.
Pressure sensor	<ul style="list-style-type: none"> If the pressure is outside the range of ± 0.03 MPa, perform Zero offset.
Pump	<ul style="list-style-type: none"> When chromatography run conditions are changed, e.g., viscosity of sample or buffer, temperature, back-pressure. Pump and pump tubing requires calibration regularly. Recommended: once a week. After the pump tubing has been replaced with new tubing. <p>Note: <i>Do not leave the pump tubing inside the Pump when the Pump is not running.</i></p>

5 Prepare the system for a run

5.3 Calibration guidelines

Module	When to calibrate
UV Monitor	<ul style="list-style-type: none">• When the signal is unstable, or readings appear to be incorrect.• After cleaning, or after replacing the UV flow cell.• When error/warning is seen on power ON.• When a Baseline ignored message is shown with a clean UV flow cell.• Before and after performing runs in the cold room.
Conductivity Monitor	<ul style="list-style-type: none">• When the signal is unstable, or readings appear to be incorrect.• After replacing the Conductivity flow cell.

5.4 System performance

Introduction

This section describes the **System performance method** and how to perform and evaluate the **System performance method** (system performance).

In this section

This section contains the following subsections:

Section	See page
5.4.1 System performance method	96
5.4.2 System performance method from ÄKTA start	98
5.4.3 System performance method from UNICORN start	102
5.4.4 Switch valve timing	105

5 Prepare the system for a run

5.4 System performance

5.4.1 System performance method

5.4.1 System performance method

Introduction

The **System performance method** is performed to make sure that the system is performing within acceptable limits. It is recommended to run the test at the time of installation of the instrument or after replacement of modules such as **Pump, UV, Conductivity** or **Valves**. **System performance method** can also be used at any time to check the condition of the system, for example, after a prolonged storage of the system. The **System performance method** can be performed from both the Instrument Display and UNICORN start.

- Note:**
- *Calibrate all the modules before starting the test.*
 - *Make sure that there is no column connected.*
 - *It is recommended not to edit any run parameters during a test in order to avoid failure of the test.*
-

Requirements

The following solutions are required:

- Buffer A - DM water
- Buffer B - 1.0% acetone, 1.0 M NaCl
- Sample - 1.0% acetone, 1.0 M NaCl (Buffer B)

Note: *Make sure to prepare the buffer solutions accurately to avoid test failure.*

Checklist

Before starting a **System performance method**, make sure that the following tasks are completed:

- Calibration of all the modules: **Pressure sensor, Pump, UV** and **Conductivity**.
- Make sure there is no column in the flow path.
- Set the conductivity reference temperature to 20°C, save and enable the function.
- Immerse Buffer port A inlet in Buffer A (DM water).
- Immerse Buffer port B inlet in Buffer B (1.0% acetone, 1.0 M NaCl).
- Immerse **Sample valve** inlet in sample (1.0% acetone, 1.0 M NaCl).
- Make sure that 1 ml Sample loop is filled with sample (1.0% acetone, 1.0 M NaCl).

5 Prepare the system for a run

5.4 System performance

5.4.1 System performance method

- Make sure that 2 m of 0.5 mm ID tubing is connected to the **Outlet valve** at Waste position.
 - When performing **System performance method** without Fraction collector, make sure the **Outlet valve** fractionation tubing is inserted into a pre-weighed beaker.
 - When performing **System performance method** with Fraction collector, make sure the **Outlet valve** fractionation tubing is connected to Fraction collector with at least 5 pre-weighed tubes.
 - Make sure that the system is prefilled with DM water.
 - Take note of all the required observations by recording parameters while the **System performance method** is in progress. Enter the observed values in the System report template provided in *Section 11.1 System Performance Report, on page 269*.
-

5.4.2 System performance method from ÄKTA start

Instruction

Follow the instructions below to initiate the **System performance method** from the Instrument Display.

Note: Insert a USB memory stick to save the results.

Step	Action
------	--------

- | | |
|---|---|
| 1 | From the ÄKTA start home screen, tap Method Run . |
|---|---|

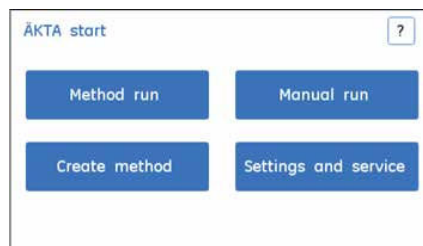

- | | |
|---|--|
| 2 | In the Method run screen, tap Prepare system . |
|---|--|



- | | |
|---|---|
| 3 | Select System performance method . To initiate the method, tap Select . |
|---|---|

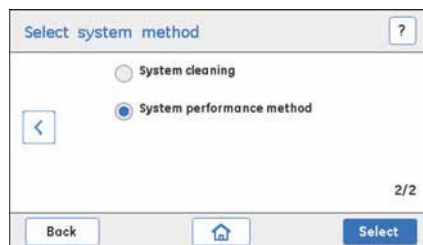

Step **Action**

- 4 Tick the check box in order to save the results on a USB memory stick, and then tap **Run** to start the System Performance test.

Note:

Provide a unique file name.

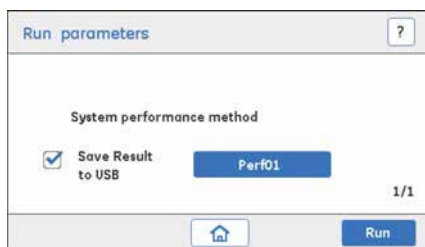

Result: The **Run view** screen will be displayed.

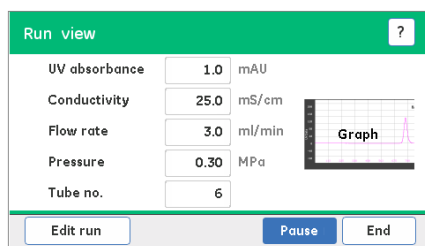

Note:

- It is recommended not to edit any run parameters during a run to avoid failure of the test.
- If required, the **System performance method** run can be ended before it is completed. Tap **End** to abort the test.

- 5 Tap **Exit** to close the screen when the **System performance method** is completed.



Note:

Do not unplug the USB memory stick until the **Exit** screen is displayed.

5 Prepare the system for a run

5.4 System performance

5.4.2 System performance method from ÄKTA start

Step	Action
6	Review the report whether the test passed or failed, based on the <i>Acceptance criteria</i> presented below.

Acceptance criteria

Time (min)	Activity	Check	Approved interval
0	Pump wash	Wash valve position	Mobile phase out through Waste
1	1 ml/min, 0% B, flow through Outlet valve, Waste position	Back pressure	≤ 0.05 MPa
2	Repeat UV Auto zero		
3	5 ml/min	Back pressure	0.06 to 0.2 MPa
		UV level	± 10 mAU
		Conductivity level	± 1 mS/cm
4	1 ml/min, Sample valve, Sample position	Max. UV level	300 to 380 mAU
		Max. Conductivity level	65 to 95 mS/cm
7	1 ml/min, Sample valve, Buffer position		
10	Request switch Injection valve to Inject position.	Max. UV level	300 to 380 mAU
		Max. Conductivity level	65 to 95 mS/cm
13	Request switch Injection valve back to Load position.		
15	Start gradient, 0% to 100% B in 10 minutes, start fractionation/collection.		

5 Prepare the system for a run

5.4 System performance

5.4.2 System performance method from ÄKTA start

Time (min)	Activity	Check	Approved interval
19	End fractionation ¹	Weigh fraction no. 2, 3 and 4.	0.8 to 1.2 g
		Max. diff. between fractions	0.1 g
20	End collection ²	Weigh beaker	4.2 to 5.8 g
25	End gradient, stay at 100% B	Gradient	Straight, no negative dips.
28	50% B	Gradient level ³	45% to 55% B
36	0% B (Re equilibration)		
41	End	Check all connections for leakage	No leakages.

¹ With Fraction collector

² Without Fraction collector

³ UV 50% B / UV 100% B

Note: If the **System performance method** fails, analyze the cause for the failure based on the acceptance criteria. Perform the following actions:

- Re-calibrate the failed module
- Use buffer with proper composition.
- Clean the failed module or entire system. Refer Chapter 8 Maintenance, on page 205 for more details on cleaning.
- Carefully follow the test instructions.
- Repeat the **System performance method** until it passes.
- If wavy or fluctuating gradient is observed, perform **Switch valve timing optimization**.
- If the test fails after following the above actions, replace the failed module.

5.4.3 System performance method from UNICORN start

Instructions

Follow the instructions below to initiate the **System performance method** from UNICORN start.

Step	Action
1	Start the test from UNICORN start System control:System:Performance Test and Report .
2	Select method based on the Fraction collector configuration: <ul style="list-style-type: none"> • Performance method with Frac: when the Fraction collector is <i>enabled</i>. • Performance method without Frac: when the Fraction collector is <i>disabled</i>.
3	Read the method notes before starting the run.
4	Make a note of the result file location.
5	Run the System performance method .
6	The test report states whether the System performance method <i>passed</i> or <i>failed</i> . Manually verify Pressure limits, Fractionation/collection volumes, gradient levels and all connections for leakage during the test, using the <i>Acceptance criteria</i> presented below.

Acceptance criteria

Time (min)	Activity	Check	Approved interval
1	1 ml/min, 0% B, flow through Outlet valve, Waste position	Back pressure	≤ 0.05 MPa
2	Repeat UV Auto zero		
3	5 ml/min	Back pressure	0.06 to 0.2 MPa
15	Start gradient, 0% to 100% B in 10 minutes, start fractionation/collection.		

5 Prepare the system for a run

5.4 System performance

5.4.3 System performance method from UNICORN start

Time (min)	Activity	Check	Approved interval
19	End fractionation ¹	Weigh fraction no. 2, 3 and 4.	0.8 to 1.2 g
		Max. diff. between fractions	0.1 g
20	End collection ²	Weigh beaker	4.2 to 5.8 g
25	End gradient, stay at 100% B	Gradient ³	Straight, no negative dips.
41	End	Check all connections for leakage	No leakages.

¹ With Fraction collector

² Without Fraction collector

³ UV 50% B / UV 100% B

- Note:**
- Make sure to update the **Performance result** text file with manually observed recordings and then print the report.
 - The other parameters are automatically checked and pass/fail reports are generated in the report. For detailed list of acceptance criteria, refer to Section 5.4.2 System performance method from ÄKTA start, on page 98.

Illustration of the System performance test

The illustration below represents a typical **System performance method** result file generated from UNICORN start.

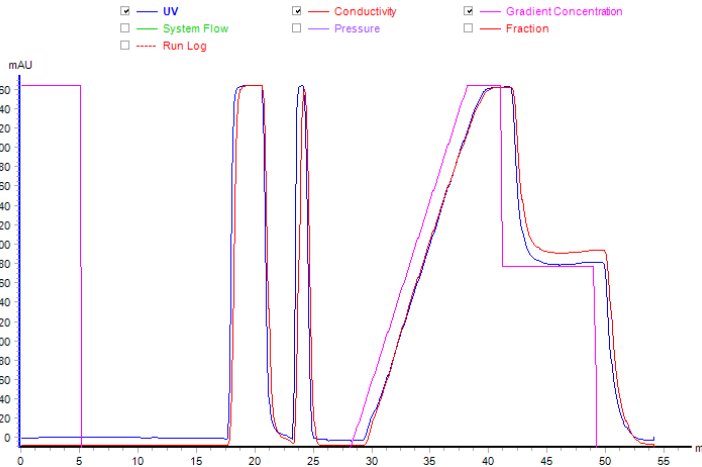

Note: It is recommended to optimize the timing of switch valve when wavy gradients or fluctuations are observed. For detailed description, see Section 5.4.4 Switch valve timing, on page 105.

Note: If the **System performance method** fails, analyze the cause for the failure based on the acceptance criteria. Perform the following actions:

- Re-calibrate the failed module
- Use buffer with proper composition.
- Clean the failed module or entire system. Refer Chapter 8 Maintenance, on page 205 for more details on cleaning.
- Carefully follow the test instructions.
- Repeat the **System performance method** until it passes.
- If wavy or fluctuating gradient is observed, perform **Switch valve timing** optimization.
- If the test fails after following the above actions, replace the failed module.

5.4.4 Switch valve timing

Introduction

Switch valve timing is used to optimize the switch valve (**Buffer valve**) timing of ÄKTA start. It is recommended to optimize the timing of switch valve when wavy gradients are obtained or when fluctuations in the step gradient are observed during either **System performance method** or chromatography runs.

- Note:**
- The default **Switch valve timing A** is 4 s.
 - **Switch valve timing B** is 5 s.
 - **Switch valve time** can be set between 3.0 and 5.0 s with 0.1 s increments using **Advanced timing**.
 - The gradient fluctuations or wavy gradients are highly dependent on the flow rates. It is recommended to modify the switch valve timing if waveness/fluctuations are seen for specific flow rates.
 - After changing the **Switch valve timing**, perform a **System performance method** to evaluate the gradient fluctuations/wavy gradients. Alternatively a manual run of 50% B for 10 min can also be performed to evaluate the gradient fluctuations/wavy gradients.
 - A manual run of 50% B for 10 min can be performed as an alternative to **System performance method** to evaluate gradient fluctuations/wavy gradients.
-

5 Prepare the system for a run

5.4 System performance

5.4.4 Switch valve timing

Illustration of a typical operation

The illustration below shows the result of a **System performance method** where fluctuations were observed in the gradient (arrow) with the default **Switch valve timing** (4 s).

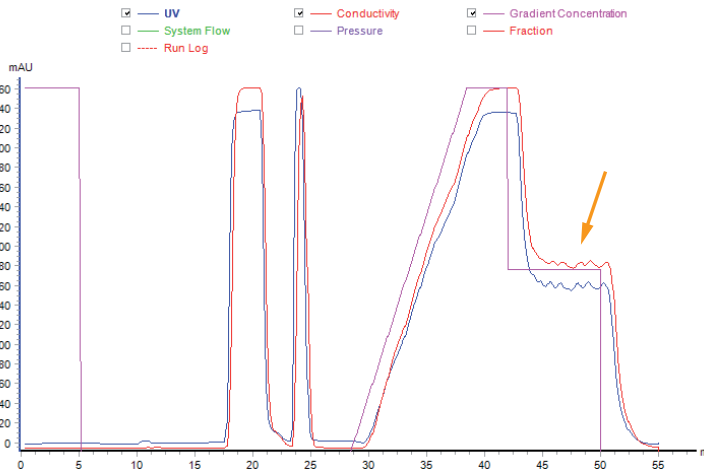

After changing the **Switch valve timing** to 5 s, the test showed an acceptable gradient performance (arrow).

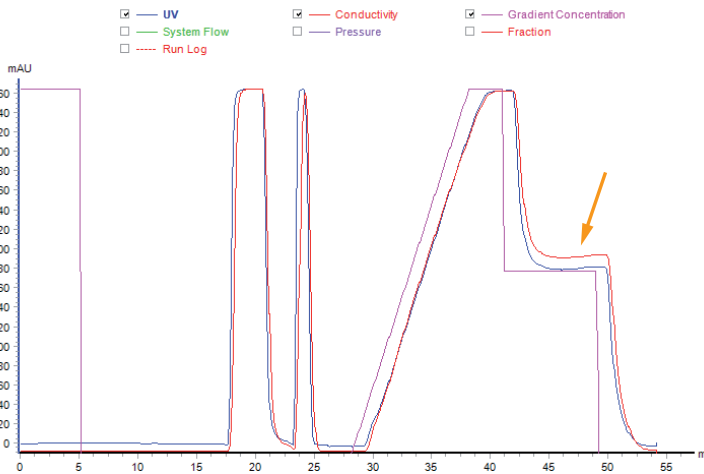

Set Switch valve timing

Follow the instructions below to change the **Switch valve timing**.

Step	Action
------	--------

- 1 In the **Settings and service** screen, tap **System**.

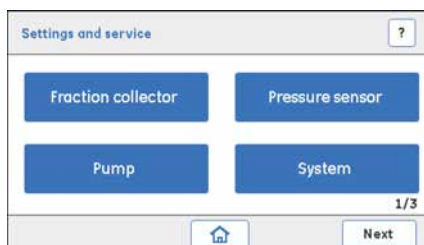

Result: The following screen opens.



- 2 In the **System** screen, tap **Switch valve timing**.

Result: The following screen opens.

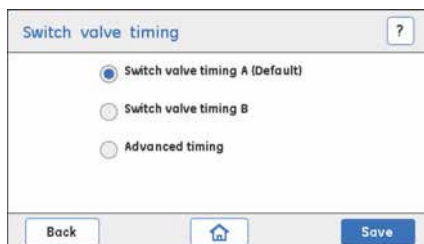

- 3 Tap the radio button to select the required timing:

- **Switch valve timing A** (switch time 4 s)
- **Switch valve timing B** (switch time 5 s)

Tap **Save** to save the timing.

- 4 Perform **Gradient run**, either by performing **System performance method** or manually set the **B concentration** (Buffer valve) to 50%. Examine the gradient for fluctuations.

5 Prepare the system for a run

5.4 System performance

5.4.4 Switch valve timing

Step	Action
------	--------

- | | |
|---|--|
| 5 | If wavy gradients still are obtained, or if fluctuations on step gradient levels are large, then select Advanced timing . |
|---|--|

Result: The following screen opens.

The screenshot shows a mobile application interface titled "Switch valve timing". At the top right is a question mark icon. Below the title are three radio button options: "Switch valve timing A (Default)", "Switch valve timing B", and "Advanced timing", with the third option selected. Below these options is a "Switch valve time" field with a dropdown arrow on the left, the value "5.0", and an up/down arrow on the right, followed by the unit "Sec". At the bottom are three buttons: "Back", a home icon, and "Save".

Set switch valve time in the range of 3.0 to 5.0 s (0.1 s increments) by pressing the up/down arrows.

- | | |
|---|---|
| 6 | Tap Save to save the optimized timing. |
|---|---|

The screenshot shows the same "Switch valve timing" screen as above, but the "Switch valve time" field now displays the value "4.3". All other elements, including the selected radio button and the "Save" button, remain the same.

5.5 Connect a column

Introduction

This section describes how to connect a column to ÄKTA start. Different types of column holders are available from GE.

The column is connected in the flow path between the **Injection valve** and **UV Monitor**, as shown in the illustration of the flow path in *Section 5.1 Flow path overview, on page 89*.

Column placement

Depending on column dimension, choose the appropriate location on the instrument to place the column. Column holder rails are located on the front and on the right side of the instrument, as shown in the image below.

- Front side of the instrument, for small columns (e.g., HiTrap™ columns)
- Right side of the instrument, for large columns (e.g., column length 60 cm)



5 Prepare the system for a run

5.5 Connect a column

Connect a column

Follow the instructions below to connect a column to the instrument.

Step	Action
------	--------

- | | |
|---|--|
| 1 | Attach an appropriate column holder to the column holder rail on the instrument. |
|---|--|



- | | |
|---|--|
| 2 | Remove the column stoppers, mount the column on the union connector if the column type requires a union. |
|---|--|



Step **Action**

- 3 Fix the column to the column holder.



- 4 Connect the 0.75 mm i.d. PEEK tubing from the **Injection valve** port 1 to the column head.

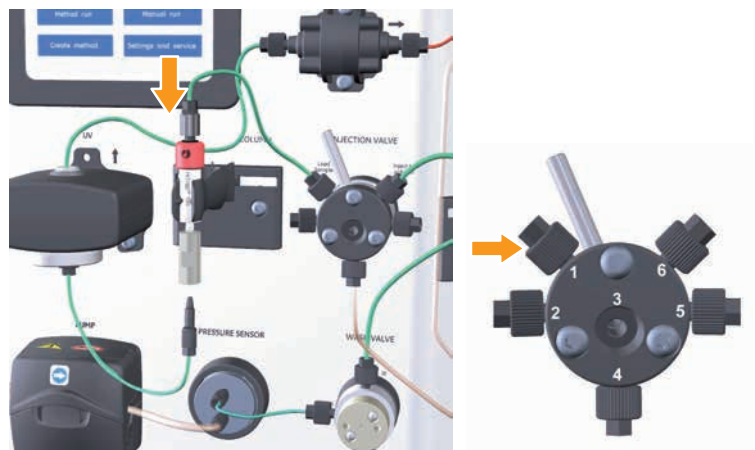

5 Prepare the system for a run

5.5 Connect a column

Step	Action
------	--------

- | | |
|---|--|
| 5 | Connect the 0.75 mm i.d. PEEK tubing from the bottom of the UV Monitor to the bottom of the column. |
|---|--|

Note:

*The 0.75 mm i.d. PEEK tubing should not be disconnected from the **UV** Monitor inlet when the column is removed. See Section 8.3.1 Disconnect the column, on page 212.*



- Note:** Do not overtighten when connecting columns. Overtightening might break the connectors or squeeze the tubing and thereby obstruct the flow.

5.6 System methods for run preparation

Introduction

This section describes how to prepare the flow path and the column before starting a chromatography run.

In this section

This section contains the following subsections:

Section	See page
5.6.1 Pump wash A	114
5.6.2 Pump wash B	116
5.6.3 Washout fractionation tubing	118
5.6.4 Column preparation	121

5.6.1 Pump wash A

Introduction

The **Pump wash A** method is used before the start of a new run or when the buffers are changed. During **Pump wash A** the flow is directed through **Wash valve** to **Waste**.

- Note:**
- **Pump wash A** is performed at 10 ml/min for 1 min through Buffer A port.
 - **Pump wash A** is important for preventing carryover and cross-contamination between buffers and/or samples.
 - It is recommended to perform the pump wash twice, first with DM water and then with the buffer of choice.
 - The **Pump wash A** method cannot be edited.
-

Requirements

The following solutions are required:

- DM water
 - Buffer solution
-

Instruction

Follow the instructions below to perform a **Pump wash A** run. The **Pump wash A** procedure is initiated from the Instrument Display.

Step	Action
------	--------

- | | |
|---|--|
| 1 | Immerse the buffer A inlet tubing in DM water or buffer. |
| 2 | In the ÄKTA start home screen, tap Method run . |

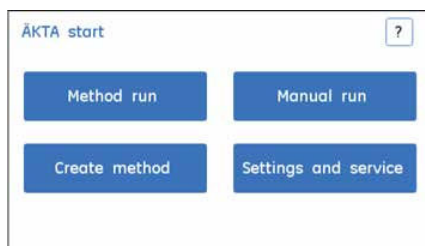

Step **Action**

3 In the **Method run** screen, tap **Prepare system**.



4 Select **Pump wash A** and then tap **Select** to initiate the method.

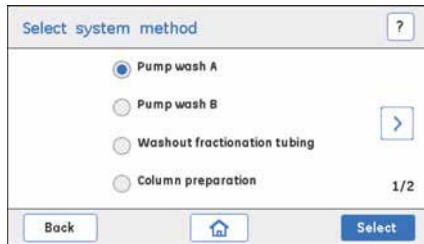

Result: The following screen opens.

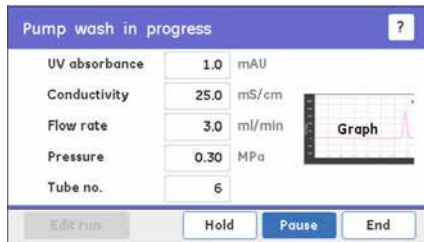

Note:

*If required, the **Pump wash A** run can be ended before it is completed by tapping **End** to stop the run.*

5 When the run is completed, tap **Exit** to close the **Pump wash A** screen.

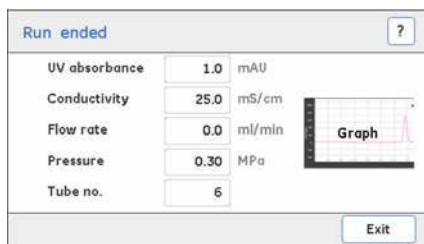

5.6.2 Pump wash B

Introduction

The **Pump wash B** method is used before the start of a new run or when the buffers are changed. During **Pump wash B** the flow is directed through **Wash valve to Waste**.

- Note:**
- **Pump wash B** is performed at 10 ml/min for 1 min through Buffer B port.
 - **Pump wash B** is important for preventing carryover and cross-contamination among buffers and samples.
 - It is recommended to perform the pump wash twice, first with DM water and then with the buffer of choice.
 - The **Pump wash B** method cannot be edited.
-

Requirements

The following solutions are required:

- DM water
 - Buffer solution
-

Instruction

Follow the instructions below to perform a **Pump wash B** run. The **Pump wash B** procedure is initiated from the Instrument Display.

Step	Action
------	--------

- | | |
|---|--|
| 1 | Immerse the buffer B inlet tubing in DM water or buffer. |
| 2 | In the ÄKTA start home screen, tap Method run . |

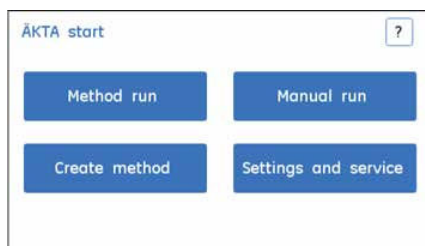

Step **Action**

3 In the **Method run** screen, tap **Prepare system**.



4 Select **Pump wash B** and then tap **Select** to initiate the method.

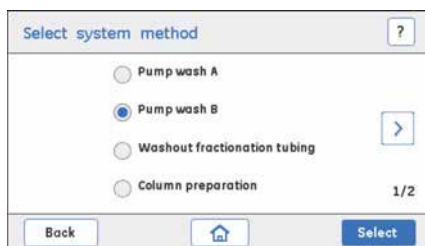

Result: The following screen opens.



If required, the **Pump wash B** run can be ended before it is completed by tapping **End** to stop the wash in advance.

5 When the run is completed, tap **Exit** to close the **Pump wash B** screen.

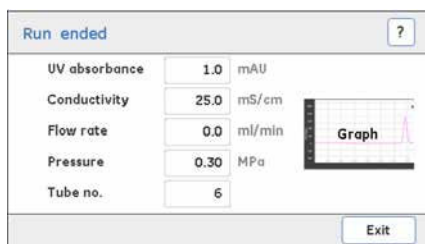

5.6.3 Washout fractionation tubing

Introduction

The **Washout fractionation tubing** method is used to rinse the fractionation tubing. It is recommended when fractions are collected using **Outlet valve** without Fraction collector, and between different runs using the Fraction collector.

Note: *Flow is diverted from fractionation tubing to collection tube, through **Outlet valve**.*

Requirements

The following solutions are required:

- DM water or buffer solution
-

Instruction

Follow the instructions below to perform a **Washout fractionation tubing** run. The **Washout fractionation tubing** procedure is initiated from the Instrument Display.

Step	Action
------	--------

- | | |
|---|---|
| 1 | Immerse the buffer inlet tubing in DM water or buffer. |
| 2 | Remove the column from the flow path and re-connect the flow path. For detailed instructions, see <i>Section 8.3.1 Disconnect the column, on page 212</i> . |
| 3 | Place the fractionation tubing in the waste container. |
| 4 | In the ÄKTA start home screen, tap Method run . |

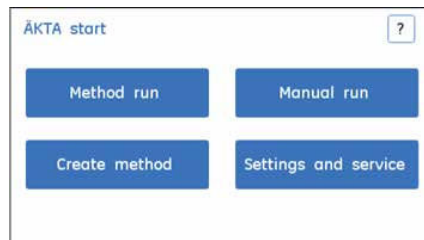

Step **Action**

5 In the **Method run** screen, tap **Prepare system**.



6 Select **Washout fractionation tubing** and then tap **Select** to initiate the method.

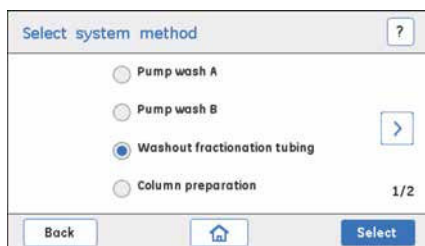

7 Set the run parameters as required:

- **Flow rate**, flow rate (ml/min)
- **Pressure limit**, pressure limit (MPa)
- **Run volume**, run volume (ml)

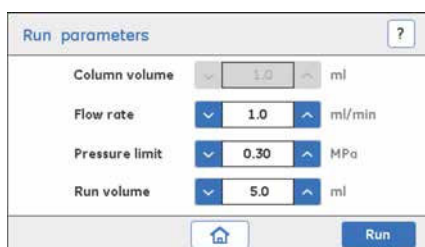

Tap **Run** to initiate the method.

5 Prepare the system for a run
5.6 System methods for run preparation
5.6.3 Washout fractionation tubing

Step **Action**

Result: The following screen opens.



Note:

*If required, the **Washout fractionation tubing** run can be ended before it is completed by tapping **End** to stop the washout in advance.*

- 8 When the run is completed, tap **Exit** to close the **Washout fractionation tubing** screen.



5.6.4 Column preparation

Introduction

The **Column preparation** method is used to prepare a new column or to equilibrate the column. It is recommended to equilibrate columns before starting a new run.

Requirements

Required solution is:

- Buffer solution
-

Instructions

Follow the instructions below to prepare the column for a run. The **Column preparation** procedure is initiated from the Instrument Display.

Step	Action
1	Immerse the buffer inlet tubing in the intended buffer.
2	Connect the column into the flow path. For detailed instructions, see <i>Section 5.5 Connect a column, on page 109</i> .
3	In the ÄKTA start home screen, tap Method run .

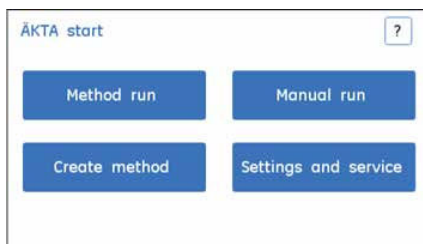

4	In the Method run screen, tap Prepare system .
---	--

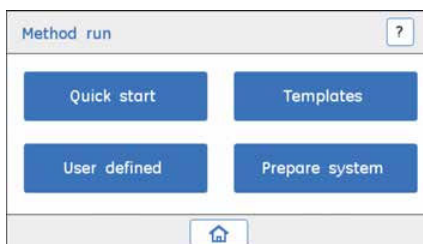

5 Prepare the system for a run
5.6 System methods for run preparation
5.6.4 Column preparation

Step **Action**

- 5 Select **Column preparation** and then tap **Select** to initiate the method. For detailed instructions, see *Section 6.4.5 Prepare system methods, on page 177*.

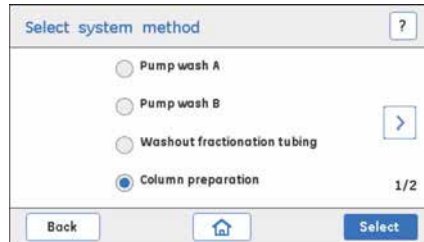

- 6 Set the required run parameters and then tap **Run** to initiate the method.



Result: The following screen opens.



Note:

*If required, the **Column preparation** run can be ended before it is completed by tapping **End** to stop the run.*

- 7 When the run is completed, tap **Exit** to close the **Column preparation** screen.

5.7 Sample application

Sample application

The table below shows the different modes of sample application available for ÄKTA start. The sample application technique can be selected from the Instrument display in the **Run parameters** screen or from UNICORN start. For details, see *Chapter 6 Operation from the Instrument Display, on page 142 and UNICORN start User Manual*.

Sample volume	Sample application	Loop type
25 µl to 10 ml	via Loop	Sample loop
10 to 150 ml	via Loop	Superloop™, 10 ml Superloop, 50 ml Superloop, 150 ml
> 5 ml	via Pump , from the Sample valve port I (Sample)	-

Note: *Make sure to load only the recommended volume of sample in the column to obtain good results. For details, see the Column instructions.*



NOTICE

Do not load turbid samples on to columns. Clarify samples first by centrifugation or filtration.

Injection valve description

The **Injection valve** enables the application of a sample onto the column from a sample loop connected to the valve. The illustration below shows the different positions of the **Injection valve**. The **Injection valve** position can be changed manually by turning the lever to the left (**Load Sample** position) or to the right (**Inject to column** position).

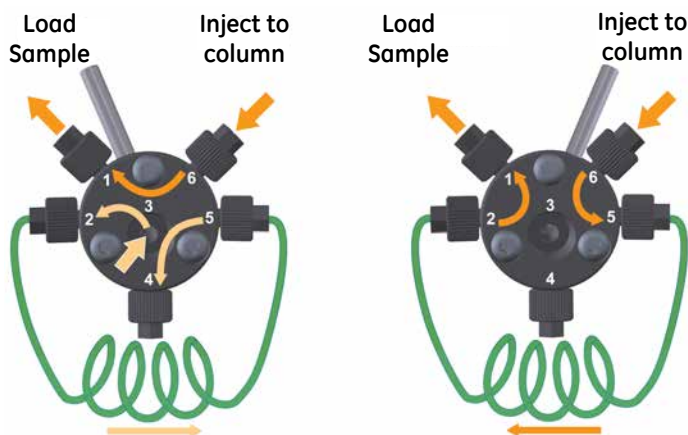

Valve position: Load Sample

Port connection	Function
6 - 1	Default route for the system flow path
3 - 2	Directs the liquid manually injected through port 3 to the sample loop. Note: <i>A sample loop or a Superloop is connected to the ports 2 and 5 of the Injection valve.</i>
5 - 4	Directs the liquid from the sample loop, through port 4 , to the waste container. Note: <i>The path indicated by light orange arrows in the illustration above is used during the manual filling of the loop (Sample or Superloop) through port 3.</i>

Valve position: Inject to column

Port connection	Function
6 - 5	Diverts the system flow path to the sample loop.

Port connection	Function
2 - 1	Directs the liquid from the sample loop to the column so that the sample loaded into the loop is transferred to the column.

Connect a sample loop

Follow the instructions below to connect a sample loop to the **Injection valve**.

Step	Action
1	Connect the sample loop between ports 2 and 5 of the Injection valve .
2	Make sure that waste tubing is connected to port 4 of the Injection valve .

Connect a Superloop

Follow the instructions below to connect a Superloop to the **Injection valve**.

Step	Action
1	Attach an appropriate column holder to the column holder rail on the right side edge of the instrument.
2	Make sure that the Superloop is filled with liquid according to the Superloop instructions.
3	Attach the Superloop to the column holder.
4	Connect the tubing from the bottom of the Superloop to port 2 of the Injection valve .

5 Prepare the system for a run

5.7 Sample application

Step	Action
5	Connect the tubing from the top of the Superloop to port 5 of the Injection valve .

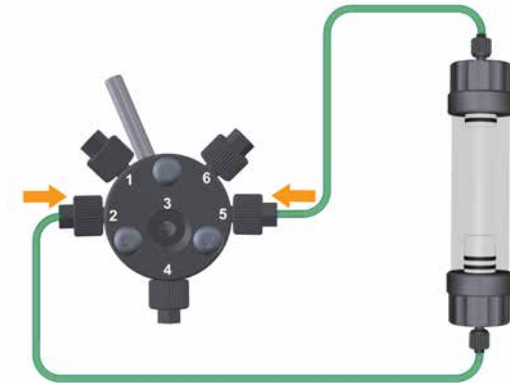

6	Make sure that port 4 of the Injection valve is connected to waste.
---	---

Prime the sample tubing using the Pump

Follow the instructions below to prime the sample tubing using DM water or Buffer, before loading the sample using the **Pump**.

Step	Action
1	Connect 1 mm i.d. ETFE (ethylene tetrafluoroethylene) tubing to port I (Sample) of the Sample valve .
2	Immerse the other end of the sample inlet tubing in the DM water/Buffer container.
3	From the Instrument Display, select Manual Run . For more details on manual run, see <i>Section 6.3 Perform a manual run, on page 149</i> .
4	Tap the forward arrow to access the run parameters on screen 2/2.

Step **Action**

- 5 Set **Sample valve** position to **Sample** so that the flow is delivered from the sample inlet.

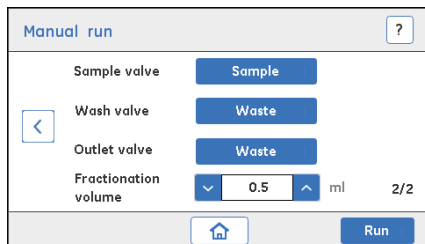

- 6 Tap **Run** to start the run.
- 7 End the run manually once the priming with required volume of DM water or buffer has completed.

Load the sample using the Pump

The sample can be applied directly using the **Pump** through the **Sample valve**. The direct sample application technique allows the application of sample volumes larger than 5 ml. Follow the instructions below to apply the sample directly using the **Pump**.

Step **Action**

- 1 Connect 1 mm i.d. ETFE tubing to port **I** (Sample) of the **Sample valve**.
- 2 Immerse the other end of the sample inlet tubing in the sample container.
- 3 From the Instrument Display, select **Method Run**.



Choose **Quick start** or **Templates**. For details, see *Section 6.4 Perform a method run, on page 158*.

5 Prepare the system for a run

5.7 Sample application

Step	Action
------	--------

- 4 In the **Run parameters** screen, select the sample application via the **Pump**.

The screenshot shows the 'Run parameters' interface. At the top, there is a title bar with a question mark icon. Below it, the 'Sample from' section has two radio buttons: 'Pump' (selected) and 'Loop'. Underneath, there are three volume settings, each with a dropdown arrow on the left and a unit on the right: 'Sample volume' is set to 0.1 ml, 'Equilibration volume' is set to 5.0 CV, and 'Wash unbound volume' is set to 15.0 CV. To the right of the last setting is a '2/3' indicator. At the bottom, there is a home icon and a blue 'Run' button.

Note:

- When the sample is applied via the **Pump**, the **Injection valve** has to be manually set to position **Load Sample**.
 - Make sure to wash the sample inlet tubing with buffer A before immersing the tubing into the sample tube. Make sure to keep sufficient volume of sample to avoid air entering the tubing.
 - Make sure that there are no trapped air bubbles in the tubing.
 - Prefill the sample tubing with sample before the start of the run to ensure that the tubing is filled with sample.
- 5 In the **Run parameters** screen, set the sample volume and the other required parameters. For details, see *Operation overview*, on page 144.
- 6 Tap **Run** to start the run.

Prime the sample loop before injecting sample

A sample loop allows the injection of small sample volumes onto the column. The sample application via the loop is performed in two steps:

- 1 Loading the sample loop with sample.
- 2 Injecting the sample from the sample loop onto the column.

Follow the instructions below to prime the sample loop using DM water or Buffer, before injecting the sample using the manual **Injection valve**.

Step	Action
------	--------

- 1 Fill a syringe with DM water or Buffer.

Note:

Make sure that the **Injection valve** is set to position **Load Sample**.

Step	Action
------	--------

- | | |
|---|---|
| 2 | Connect the syringe to the Injection valve port 3 . |
|---|---|



- | | |
|---|---|
| 3 | Load the DM water or buffer into the sample loop. |
| 4 | Repeat steps 1 to 3 using a total of at least 5 times the loop volume, before loading the sample. |

Load the sample into the sample loop

Follow the instructions below to load the sample into the sample loop.

Note: *Make sure to flush the loop with DM water and buffer using at least 5 times the loop volume before injecting the sample.*

Step	Action
------	--------

- | | |
|---|-----------------------------|
| 1 | Fill a syringe with sample. |
|---|-----------------------------|

5 Prepare the system for a run

5.7 Sample application

Step	Action
------	--------

- | | |
|---|---|
| 2 | Connect the syringe to the Injection valve port 3 . |
|---|---|



Note:

Make sure that the **Injection valve** is set to position **Load Sample**, which allows the sample loop to be filled from the fill port **3**.

- | | |
|---|---|
| 3 | Carefully load the sample into the sample loop. To avoid sample loss due to siphoning, leave the syringe in the port until the sample has been injected onto the column during the run. |
|---|---|

Tip:

It is recommended to overfill the loop to make sure that the loop is completely filled. Excess sample will leave the valve through port **4**.

- | | |
|---|--|
| 4 | From the Instrument Display select Method run , then choose Templates . For details, see Section 6.4 Perform a method run, on page 158 |
|---|--|

Step **Action**

- 5 In the **Run parameters** screen, select the sample application via the **Loop** and set all the required run parameters. For details, see *Chapter 6 Operation from the Instrument Display, on page 142*.

When the following screen is shown on the Instrument Display, switch the **Injection valve** position to the **Inject to column** position.

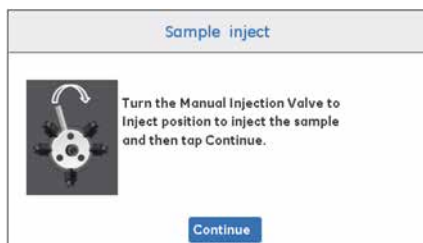

- 6 After manually switching position, acknowledge the message by tapping **Continue**.

The sample will be injected onto the column when the **Injection valve** is switched manually to position **Inject to column** during the run.

- 7 When the following screen is shown on the Instrument Display, Switch the **Injection valve** position to the **Load Sample** position.



- 8 After manually switching the position of the **Injection valve**, acknowledge the message by tapping **Continue**.

Note: For binding techniques (affinity chromatography/ion exchange chromatography, AC/IEX) it is advisable to flush the loop with at least 3 times the loop volume to ensure complete sample loading. This is not recommended for non-binding techniques (desalting/gel filtration, DS/GF) as there are sample volume limitations due to the size of the column used.

Load the sample from a Superloop

Use of a Superloop allows the injection of larger volumes of sample (10 to 150 ml) onto the column. Follow the instructions below to apply the sample using a Superloop.

Step	Action
------	--------

- | | |
|---|---|
| 1 | Fill a large volume syringe with sample. |
| 2 | Connect the syringe to the Injection valve port 3 and carefully inject the sample into the Superloop. |

Note:

Make sure that the **Injection valve** is set to position **Load sample**, which allows the Superloop to be filled from the fill port **3**.

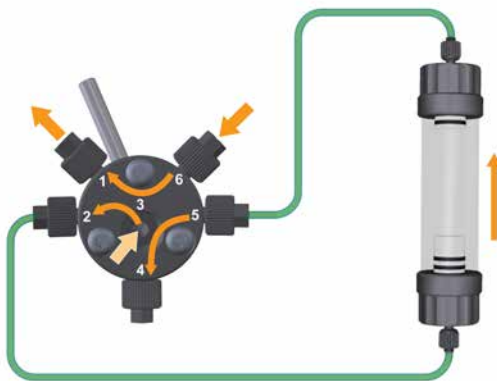

- | | |
|---|---|
| 3 | From the Instrument Display select Method run , then choose Quick start methods or Templates . For details, see <i>Section 6.4 Perform a method run, on page 158</i> . |
| 4 | In the Run parameters screen, select the sample application via the Loop and set all the required run parameters. For details, see <i>Operation overview, on page 144</i> . |

Step **Action**

- 5 When the following screen is shown on the Instrument Display, switch the **Injection valve** position to the **Inject to column** position.

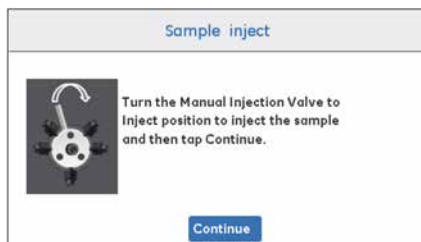

- 6 After manually switching position, acknowledge the message by tapping **Continue**.

- 7 When the following screen is shown on the Instrument Display, switch the **Injection valve** position to the **Load Sample** position.



The sample will be injected onto the column when the **Injection valve** is switched manually to the position **Inject to column** during the run.

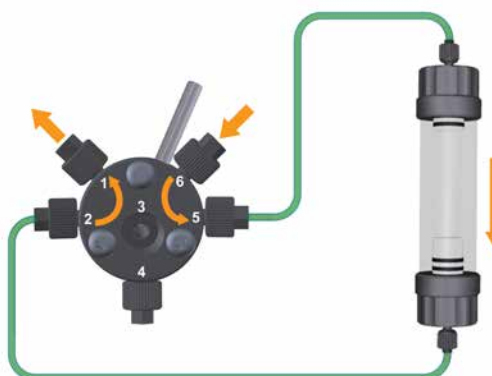

- 8 After manually switching the position of the **Injection valve**, acknowledge the message by tapping **Continue**.
-

5.8 Prepare the Fraction collector

Prepare the Fraction collector

Fractions are collected in tubes using the Fraction collector. Follow the instructions below to prepare the Fraction collector if the Fraction collector is going to be used during a run.

The following types of tubes can be placed in the tube holder of the Bowl assembly:

- Eppendorf™ tubes (1.5 ml or 2 ml)
- 5 ml tubes (12 × 75 mm)
- Centrifuge tubes (10 to 12 ml)
- Falcon™ tubes (15 ml)



NOTICE

The Fraction collector should be connected or disconnected from the instrument only when ÄKTA start is switched off.

Note: Make sure that the Fraction collector is properly installed. See *Connect Frac30 to ÄKTA start*, on page 83.

Step	Action
------	--------

1	Insert a sufficient number of collection tubes in to the Bowl assembly.
---	---

Note:

All the tubes must be of the same length and diameter and there should be no empty spaces in the sequence.

2	Connect a 0.75 mm i.d. PEEK tubing to the Outlet valve port III (Collection).
---	---

Note:

The tubing must be about 50 cm long to allow proper placement of the Fraction collector and free movement of the dispenser arm.

Step	Action
3	Loosen the nut of the tubing holder and insert the outlet tubing into the tubing holder. Tighten the nut.

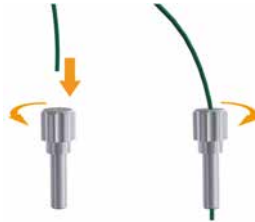

Note:

The PEEK tubing should extend slightly (2 to 3 mm) out of the tubing holder. Make sure that the extended length of the tubing is short enough to avoid collision with the test tubes during fractionation.

4	Fit the tubing holder into the corresponding port on the Dispenser arm. Use the outer or inner port according to the type of collection tubes inserted in the Bowl assembly.
---	--

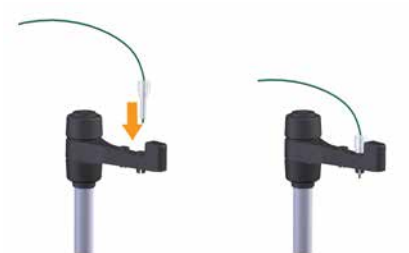

5 Prepare the system for a run

5.8 Prepare the Fraction collector

Step	Action
------	--------

- | | |
|---|---|
| 5 | Gently move the arm to the dispensing position. |
|---|---|



Set the delay volume

The delay volume represents the volume between the **UV** and the Fraction collector or the outlet that is used. The delay volume is set so that the fractions collected during fractionation correspond to the fractions indicated in the chromatogram.

When the Fraction collector is enabled, the delay volume is collected in the first tube (T1) and the elution volume is collected in the subsequent tubes. Without the Fraction collector enabled, the delay volume is collected in the collection beaker (the total collected volume in the collection beaker will be *delay volume* + *elution volume*).

If the length and/or diameter of the tubing is changed, set the delay volume accordingly. Follow the instructions below to set the delay volume.

Note: *The delay volume from **UV** to **Outlet valve** is constant (0.27 ml) in all ÄKTA start instruments if the recommended tubing dimensions are used (see Section 10.1 Specifications, on page 252).*

Step **Action**

- 1 In the **ÄKTA start** home screen, tap **Settings and service** to access the instrument modules.

Result: The **Settings and service** Screen 1 opens.



- 2 In the **Settings and service** screen, tap **System** to access the system options.

Result: The **System** screen opens.



- 3 In the **System** screen, tap **Delay volume setting** to access the settings.

Result: The **Delay volume settings** screen opens.

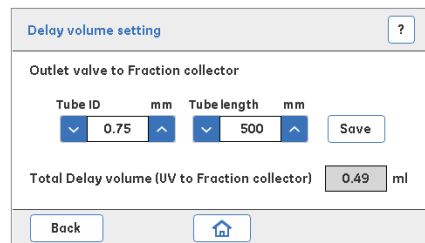

- 4 Enter the internal diameter (ID) in the **Tube ID** field and length of the tubing from the **Outlet valve** to Fraction collector in the **Tube length** fields, and then tap **Save**.

Result: The total delay volume from **UV** to Fraction collector is displayed in the **Total delay volume** field.

5.9 Operation in a cold room

Introduction

ÄKTA start may be placed in a cold room for purification of temperature sensitive biomolecules.

Refer to *Guidelines for protein purification at low temperature* (part no. 29170790).

Preparation

Follow the instructions below to prepare the instrument for a run in the cold room.

Step	Action
1	Place ÄKTA start in the cold room.
2	If a UNICORN start computer is connected to the instrument, leave the computer outside the cold room.
3	Allow the instrument to stabilize at the temperature of the cold room.
4	Tighten all connections and pump DM water through the system to check for leaks.
5	Tighten any leaking connector.

Starting a run

Before starting a run, make sure that the temperature of the buffers has reached the temperature set in the cold room.

Note: *The measured temperature of the system is the temperature in the **Conductivity flow cell**, which can differ from the ambient temperature.*

Removal from the cold room

Follow the instructions below to remove the instrument from the cold room.

Step	Action
1	Switch off the instrument and disconnect the power cable before moving the instrument out of the cold room.

Step	Action
2	Loosen all connections to prevent them sticking when the system returns to room temperature.
3	Allow the instrument to stabilize at room temperature for at least a few hours.
4	Tighten all connections and pump DM water through the system to check for leaks.
5	Tighten any leaking connector.

Purification at low temperatures with Size Exclusion Chromatography (SEC) columns

The lower flow-rate limit for ÄKTA start is 0.5 ml/min. Low temperature can cause problems if the flow rates need to be lower than 0.5 ml/min. This may be a factor when using size exclusion chromatography columns with high-viscosity buffers where a lower flow rate is needed.

If a high back-pressure is experienced with a column connected to ÄKTA start while being used in the cold room, it might be necessary to bring the instrument and column to room temperature to complete the purification run or cleaning of the column. This is more likely to occur with HiPrep™ Sephacryl™ columns compared to HiTrap columns.

5.10 Starting a run

Final checks

Before starting a run, make the checks recommended below to avoid problems occurring once the run has been started.

Buffer

- Check that the buffer inlet tubings A and B are immersed in the correct bottles containing the buffers of interest.
- Check that there is sufficient buffer available.

Waste outlet

- Check that the outlet tubings leading to waste from the **Wash valve**, **Injection valve**, and the **Outlet valve** are placed in the waste container.
- Check that there is sufficient room in the waste container for waste generated during the run.

Fraction collector

- If the fraction collector, Frac30 is going to be used during the run, check that the fraction collector is prepared and filled with appropriate collection tubes, and that the **Outlet valve** collection PEEK tubing is connected to the Fraction collector. Make sure that the Fraction collector is enabled.

Column

- Check that the correct column has been connected and equilibrated (if equilibration is not included in the method).

Sample

- Make sure that the sample is ready to be loaded via **Pump**, Loop, or Superloop.

Pump

- Make sure that the pump tubing is placed properly over the pump head. Make sure that the pump head is properly closed before starting the run.

Result storage

- If the run is operated from the Instrument Display, make sure that a USB memory stick is connected to the instrument to save the results.

UNICORN start

- Check that ÄKTA start is connected to a PC with UNICORN start installed.
- Make sure that the system connection is established before starting the run. For details, refer to *UNICORN start User Manual*.

Start a run

A chromatography run is performed on ÄKTA start either by using a **Quick start** method or **Template**, or by running the system manually. A run can be started from the Instrument Display or from UNICORN start by selecting one of the run options available with the instrument.

Detailed instructions for starting a run are presented in *Chapter 6 Operation from the Instrument Display, on page 142*. For starting a run from UNICORN start, refer to *UNICORN start User Manual*.

6 Operation from the Instrument Display

About this chapter

This chapter describes how to operate the instrument, perform a run and the procedures after a run, from the Instrument Display, without using UNICORN start.

In this chapter

This chapter contains the following sections:

Section	See page
6.1 Introduction	143
6.2 Fractionation	146
6.3 Perform a manual run	149
6.4 Perform a method run	158
6.5 Procedures after a run	180
6.6 Manage methods and files	183

6.1 Introduction

Workflow

A run can be performed by either using a **Quick start** method, **Template**, or user-defined method, or by operating the system manually. The alternatives are shown in the illustration below.

The options for starting a run from the instrument display are:

- **Manual run**
- **Method run**

Detailed instructions are presented in *Section 6.3 Perform a manual run, on page 149* and *Section 6.4 Perform a method run, on page 158*.

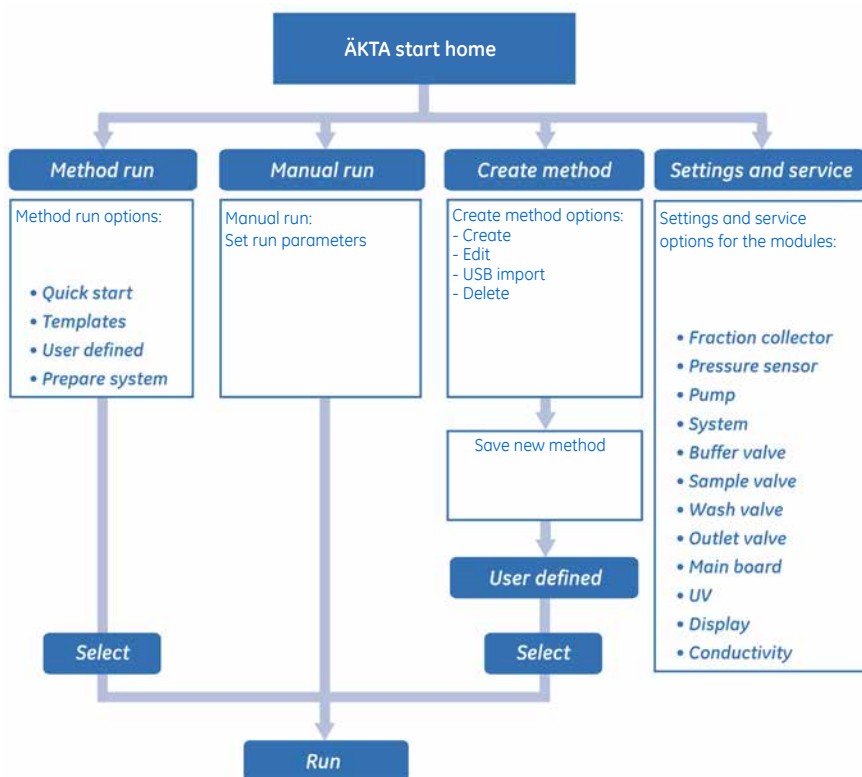

Procedures required after a run, such as cleaning the column and the system flow path, can also be performed manually or using methods available in the **Prepare system** menu.

6 Operation from the Instrument Display

6.1 Introduction

Calibration of the modules and service are performed from the **Settings and service** screen. Calibration may be necessary before a run is started (see *Section 5.3 Calibration guidelines, on page 93*).

Method management operations such as creating, editing, and importing a method are performed from the **Create method** screen. For detailed instructions, see *Section 6.6 Manage methods and files, on page 183*.

Operation overview

The **ÄKTA start** home screen displays four different options. Instructions for each operation are presented in separate sections in this chapter. For a description of the options available in the home screen, see *Section 3.3.1 Overview of the Instrument Display, on page 48*.

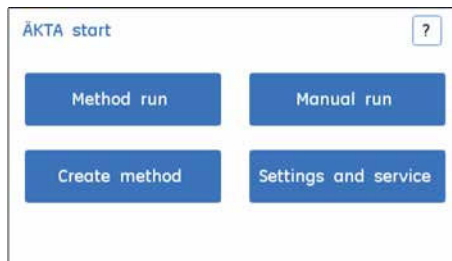

Checklist

Make sure that the system is correctly prepared. Check that:

- The system is prepared according to *Chapter 5 Prepare the system for a run, on page 88* and the modules are calibrated according to *Section 5.3 Calibration guidelines, on page 93*.
- A suitable column has been selected for the application. Consider target protein, pressure range, and optimal flow rate.
- A suitable sample application technique will be used. See *Section 5.7 Sample application, on page 123*.
- The buffer inlet tubing is immersed into correct buffer bottles. Consider the volume required for the intended application.
- The waste tubing is inserted into an appropriate waste container. Consider container size and its material.
- No tubing is twisted or blocked and the flow path is free from leakage.
- The Fraction collector configuration is either enabled or disabled as required.

- If the Fraction collector is used, make sure to use tubes with the same tube size.
 - The delay volume is set.
 - A USB memory stick is connected to the instrument. The results of the run will not be saved if the instrument does not detect a USB memory stick.
-

6.2 Fractionation

Fractionation options

ÄKTA start offers the fractionation options presented in the table below.

Instrument configuration	Fractionation options
ÄKTA start + UNICORN start + Frac30	<ul style="list-style-type: none"> • Fixed volume fractionation • Peak fractionation <ul style="list-style-type: none"> - Level based - Slope based
ÄKTA start + UNICORN start	<ul style="list-style-type: none"> • Single Peak collection <ul style="list-style-type: none"> - Level based
ÄKTA start + Frac30	<ul style="list-style-type: none"> • Fixed volume fractionation
ÄKTA start	<ul style="list-style-type: none"> • Collection of elution volume

Handling the delay volume

For setting the delay volume refer to *Section 5.8 Prepare the Fraction collector, on page 134*. The delay volume is handled differently according to whether the eluate is fractionated with Frac30 or collected in any other way.

Collection	Delay volume
With Frac30	The delay volume is collected in the first tube (T1), followed by the rest of the fractions in the subsequent tubes.
Without Frac30	The delay volume is collected in the collection container along with the first fraction (i.e., Total collected volume = delay volume + fraction volume).

Fractionation using ÄKTA start

For detailed instructions on fractionation operations using UNICORN start, refer to *UNICORN start User Manual*.

ÄKTA start with Frac30

A representative chromatogram depicting fractionation using fixed volume fraction collection in ÄKTA start with Frac30 is shown below.

Note: Make sure to set fraction volumes that suit the column being used and use an adequate number of collection tubes.

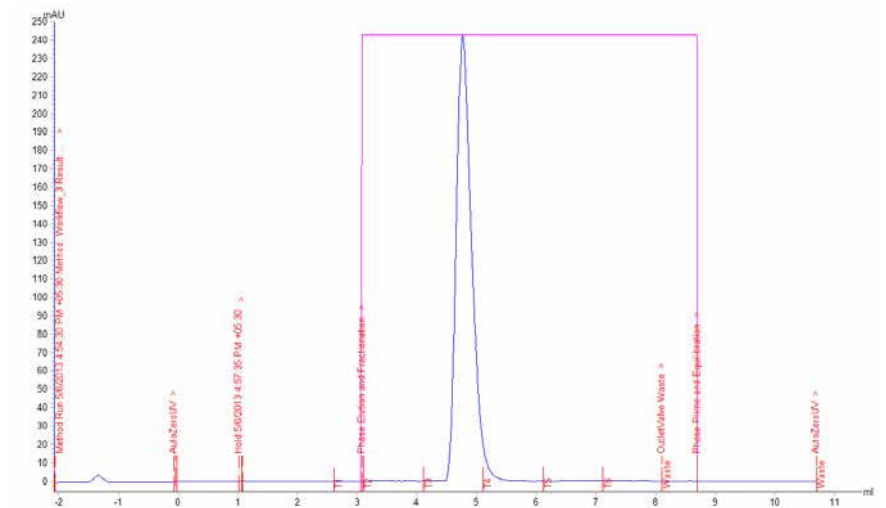

ÄKTA start using the Outlet valve (without Frac30)

A representative chromatogram depicting collection using the **Outlet valve** in ÄKTA start (without Frac30) is shown below.

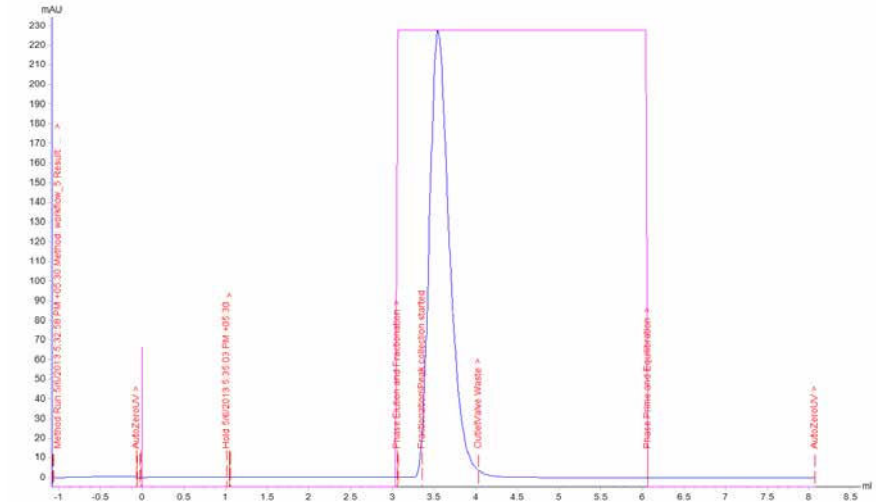

- Note:**
- The **UV to Outlet valve** volume (0.27 ml) is constant for all ÄKTA start instruments if the recommended tubing dimensions are used.
 - Make sure to use recommended length and ID of PEEK tubing from **UV to Outlet valve** to avoid incorrect calculation of the delay volume.
 - Make sure to update the length and ID of the PEEK tubing (**Settings and service: System: Delay volume setting**) in case the tubing is not of the recommended length and ID.

6.3 Perform a manual run

Introduction

This section describes how to start a manual run by configuring the run parameters from the instrument display and how to control an ongoing run.

In this section

This section contains the following subsections:

Section	See page
6.3.1 Manual run	150
6.3.2 Monitor and control the run	153

6 Operation from the Instrument Display

6.3 Perform a manual run

6.3.1 Manual run

6.3.1 Manual run

Start a run

Follow the instructions below to start a manual run.

Note: *Make sure that a USB memory stick is connected to the instrument. If the instrument does not detect a USB memory stick, the result will not be saved.*

Step	Action
------	--------

- | | |
|---|--|
| 1 | In the ÄKTA start home screen, tap Manual run to access the run parameters for a manual run. |
|---|--|

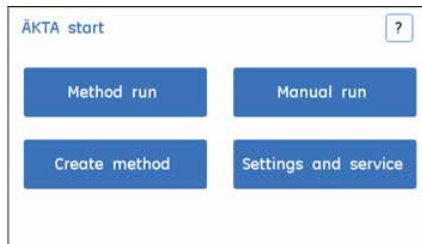

Step Action

2

The screenshot shows the 'Manual run' configuration screen. It features three rows of controls: 'Flow rate' set to 1.0 ml/min, 'Pressure limit' set to 0.50 MPa, and 'Conc B' set to 0 %. Below these is a checked checkbox for 'Save Result to USB' with a file name field containing 'ManRes01' and a page indicator '1/2'. At the bottom, there is a home button and a blue 'Run' button.

- Set run parameters:
 - **Flow rate**, flow rate (ml/min)
 - **Pressure limit**, pressure limit (MPa)
 - **Conc B**, buffer B concentration (%)

Use up/down arrows to set the values, or use the numpad to type in the values.

- Tick the checkbox **Save Result to USB** if you want to save the result. The result file name can be edited by setting the digits in the range 00 to 99.
- Tap the forward arrows to access additional run parameters.
- Tap **Run** when all required parameters have been set.

Note:

Make sure that the values for the Flow rate and Pressure limit are appropriate for the chosen column. Refer to the column manual for details.

*If the pressure exceeds the set limit, the instrument will enter the **Pause** state.*

6 Operation from the Instrument Display

6.3 Perform a manual run

6.3.1 Manual run

Step	Action
------	--------

3

Manual run		?
Sample valve	Buffer	
Wash valve	Column	
Outlet valve	Collection	
Fractionation volume	0.5 ml	2/2
		Run

- Set the valve positions as required:
 - **Sample valve**: set as **Buffer** or **Sample** so that the flow is delivered from either the buffer inlets or the sample inlet.
 - **Wash valve**, set as **Column** or **Waste** to direct the flow either to the column or to waste.
 - **Outlet valve**, set as **Collection** or **Waste** to direct the flow either to the Fraction collector or to waste.
- Set the **Fractionation volume**, the volume of the fraction to be collected when the Fraction collector is enabled.
Use up/down arrows to set the value, or use numpad to type in the value.

Note:

To collect fractions, place the required number of tubes of adequate volume in the Bowl assembly and make sure that the Fraction collector is enabled. If enabled, the Fraction collector will home to position 1 at the beginning of every run.

- Tap **Run** to start the run.
*Result: The **Run view** screen will be displayed.*

6.3.2 Monitor and control the run

Overview

From the **Run view** screen, the user can monitor and control the ongoing run.

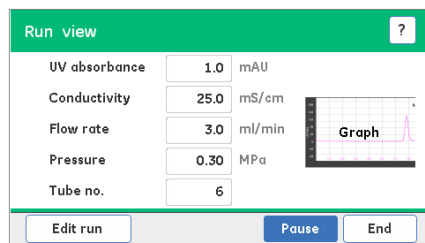

The following options are available:

Option	Description
Graph	Displays the run-time UV absorbance curve.
Edit run	Allows the user to edit the run parameters of the ongoing run.
Pause	Temporarily pauses the run by stopping the Pump , hence no flow of liquid in the flow path.
End	Terminates the current run.

View the chromatogram

Follow the instruction below to view the chromatogram of the ongoing run.

Step	Action
1	<p>The screenshot is identical to the one above, but the 'Graph' icon is highlighted with a blue border, indicating it should be tapped.</p>

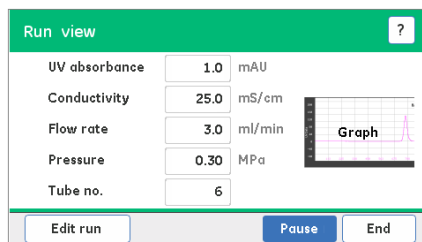

In the **Run view** screen, tap the graph icon to view the chromatogram.

6 Operation from the Instrument Display

6.3 Perform a manual run

6.3.2 Monitor and control the run

Step	Action
------	--------

2

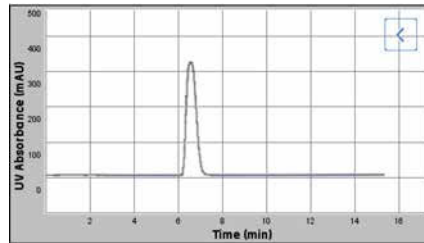

The graph displays the UV curve. The Y axis displays the UV absorbance (mAU) and X axis the time (min).

Tap the return arrow to return to the **Run view** screen.

Edit the run

Follow the instruction below to edit the run parameters of an ongoing run.

Step	Action
------	--------

1

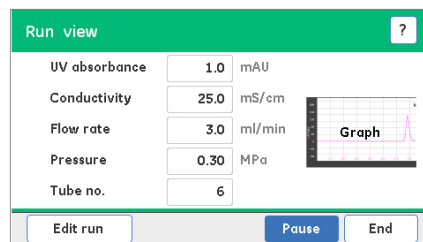

The figure shows a 'Run view' screen with a green header bar containing a question mark icon. Below the header, there are five rows of parameters, each with a text label, a numeric input field, and a unit label: 'UV absorbance' (1.0 mAU), 'Conductivity' (25.0 mS/cm), 'Flow rate' (3.0 ml/min), 'Pressure' (0.30 MPa), and 'Tube no.' (6). To the right of these parameters is a small 'Graph' window showing a peak. At the bottom of the screen are three buttons: 'Edit run', 'Pause', and 'End'.

In the **Run view** screen, tap **Edit run** to access the run parameters of the ongoing run.

Step	Action
------	--------

2

- Edit the run parameters:

Conc B, buffer B concentration (%)

Flow rate, flow rate (ml/min)

Fractionation volume, fractionation volume (ml)

Toggle **Fractionation** between **Start** and **Stop** to start or stop the fractionation.

Use up/down arrows to adjust the values, or use the numpad to type in the values.

If no other parameters need to be set, tap **Execute** to implement the changes. To ignore the changes, tap **Cancel**.

- Tap the forward arrow to access additional run parameters.

3

- Toggle as needed to set which valve positions are open:
 - **Sample valve**: set as **Buffer** or **Sample** so that the flow is delivered from either the buffer inlets or the sample inlet
 - **Wash valve**: set as **Column** or **Waste** to direct the flow to either the column or to waste
 - **Outlet valve**: set as **Collection** or **Waste** to direct the flow to either the Fraction collector or to waste

6 Operation from the Instrument Display

6.3 Perform a manual run

6.3.2 Monitor and control the run

Step	Action
------	--------

- Tick the **Autozero UV** checkbox if a **UV** baseline to zero is required.
- Tick the **Set event mark** checkbox if you need to set an event mark in the chromatogram.
- After you have set the run parameters, tap **Execute** to implement the changes.

Pause the run

Follow the instruction below to pause an ongoing run.

Step	Action
------	--------

- 1 In the **Run view** screen, tap **Pause** to temporarily pause the run by stopping the **Pump**.

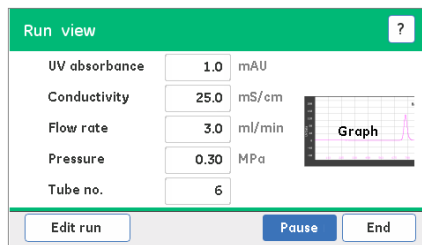

- 2 To continue the run, tap **Continue**.

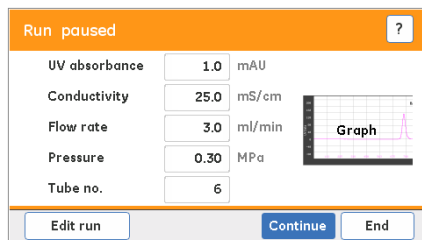

Note:

There is no liquid flow in the flow path when the run is paused.

End the run

Follow the instruction below to end an ongoing run.

Step	Action
------	--------

- | | |
|---|---|
| 1 | In the Run view screen, tap End to terminate the run. |
|---|---|

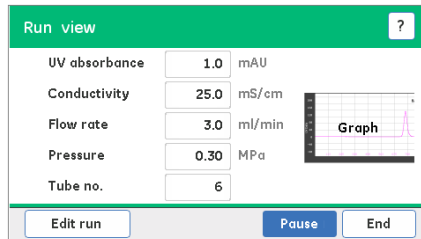

Result: A Message screen opens, requiring confirmation of the action.

- | | |
|---|--|
| 2 | |
|---|--|



Tap **Yes** to confirm that you want to terminate the run or tap **No** to cancel the action and return to the **Run view** screen.

Note:

When a run is terminated before it is completed, the partial result is stored on the USB memory stick.

The USB memory stick stores the result files which can be viewed using UNICORN start. Also a BMP file is generated which can be viewed from any PC. For details, refer to Section 6.6.3 BMP result file, on page 196.

Do not remove the USB memory stick before the save operation is complete.

- | | |
|---|--|
| 3 | |
|---|--|

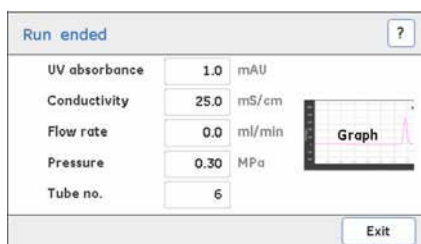

Tap **Exit** to close the **Run ended** screen.

6.4 Perform a method run

Introduction

This section describes the types of methods that can be selected for a run.

In this section

This section contains the following subsections:

Section	See page
6.4.1 Select a method type	159
6.4.2 Quick start	161
6.4.3 Templates	167
6.4.4 User defined methods	175
6.4.5 Prepare system methods	177

6.4.1 Select a method type

Method types

Four different method types can be selected to perform a method run. The different method types are specified below.

Quick start: Allows the user to run methods like affinity, Ion exchange, Gel filtration and Desalting with method parameters predefined.

Templates: Allows the user to edit and run the predefined methods Affinity, Ion exchange, Gel filtration and Desalting.

User defined: Allows the user to run user created methods or USB imported methods.

Prepare system: Allows the user to perform system operations, such as Pump wash, Column preparation, Cleaning and System performance test.

The **Quick start** methods and **Templates** available with ÄKTA start are briefly described in Section 6.4.2 *Quick start*, on page 161 and Section 6.4.3 *Templates*, on page 167.

For a description of the **Prepare system** methods, see Section 6.4.5 *Prepare system methods*, on page 177, and Section 8.3 *Cleaning the system flow path*, on page 210.

Method type	Option
Quick start	<ul style="list-style-type: none"> • AC step 1 ml HiTrap • AC step 5 ml HiTrap • DS 5 ml HiTrap • DS 53 ml HiPrep • IEX step 1 ml HiTrap • IEX step 5 ml HiTrap • IEX gradient 1 ml HiTrap • IEX gradient 5 ml HiTrap • GF 16/60 HiPrep
Templates	<ul style="list-style-type: none"> • Affinity (AC) • Desalting/buffer exchange (DS) • Ion exchange (IEX) • Gel filtration (GF)
User defined	Methods created by the user, based on the predefined templates.

6 Operation from the Instrument Display

6.4 Perform a method run

6.4.1 Select a method type

Method type	Option
<i>Prepare system</i>	<ul style="list-style-type: none">• <i>Pump wash A</i>• <i>Pump Wash B</i>• <i>Washout fractionation tubing</i>• <i>Column preparation</i>• <i>System cleaning</i>• <i>System performance method</i>

Select a method

Follow the instruction below to select a method.

Step	Action
------	--------

1

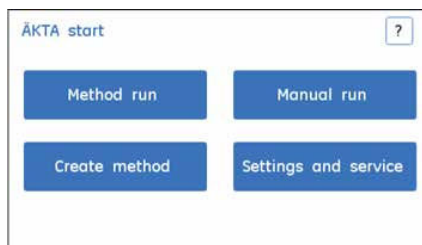

In the **AKTA start** home screen, tap **Method run** to access the method types available with the instrument.

2



Select one of the following methods:

- *Quick start*
- *Templates*
- *User defined*
- *Prepare system*

6.4.2 Quick start

Introduction

Quick start contains "ready to run" methods to purify most common proteins based on Affinity, Ion exchange, Gel filtration and Desalting techniques. Run parameters like column volume, flow rate, equilibration and elution mode, and volume are predefined in the method. The user needs to enter only the sample volume. For detailed description of each **Quick start** method, refer to *ÄKTA start System Cue Card*.

Note: *If required, the run parameters can be changed using the **Edit run** option during an ongoing run.*

Quick start techniques

The table below describes the various kinds of quick start techniques that a user can choose, based on application requirements.

Method	Chromatography Technique	Details
AC step 1 ml/5 ml HiTrap	Affinity Chromatography	Bound proteins are eluted in a single step, using a single elution buffer. Commonly used for purification of tagged proteins, for example Histidine-tagged proteins.
DS 5 ml HiTrap/53 ml HiPrep	Desalting	Proteins are eluted in a single step, using a single elution buffer.
IEX step 1 ml/5 ml HiTrap	Ion Exchange Chromatography	Bound proteins are eluted in a single, step using a single elution buffer.
IEX gradient 1 ml/5 ml HiTrap	Ion Exchange Chromatography	Bound proteins are eluted using two buffers with linear increase in the concentration of buffer B, over a specified time followed by a step of 100% B.
GF 16/60 HiPrep	Gel Filtration	Proteins are eluted in a single step, using a single elution buffer.

Note: *It is recommended to use the appropriate column as indicated in the template names. For example, use HiTrap 1 ml column when selecting AC/IEX step1 ml HiTrap, or 5 ml column when selecting AC/IEX step 5ml HiTrap.*

6 Operation from the Instrument Display

6.4 Perform a method run

6.4.2 Quick start

Start a run

Follow the instruction below to start a run based on a **Quick start** method.

Note: *Make sure that a USB memory stick is connected to the instrument. If the instrument does not detect a USB memory stick, the result will not be saved.*

Step	Action
------	--------



In the **Method run** screen, tap **Quick start** to access the templates.

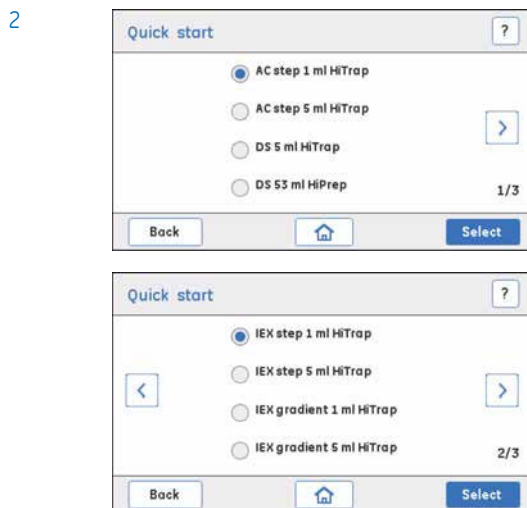

Step	Action
------	--------



- To select a **Quick start** method, tap a radio button
or
Tap the forward arrow to access additional **Quick start** methods.
- To continue with the selected method, tap **Select**.

Note:

Make sure to load the recommended sample volume for the selected column. If large Gel filtration columns are used, it is recommended to pre-equilibrate the column before starting the run.

3

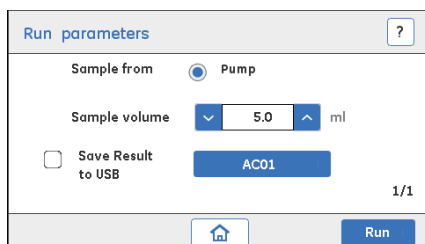

- The mode of sample application is **Pump** (default).

Note:

Sample application using **Pump** is used for all **Quick start** methods to automate sample loading or to have an unattended chromatographic run.

Note:

Sample application via **Loop** is not applicable.

6 Operation from the Instrument Display

6.4 Perform a method run

6.4.2 Quick start

Step	Action
------	--------

- Enter the sample volume in the **Sample volume** field .
Use up/down arrows to set the values, or use numpad to type in the values.
- Tick the checkbox **Save Result to USB** if you want to save the result. The result file name can be edited by setting the digits in the range 00 to 99.
- Tap **Run** to start the run.
Result: The **Run view** will be displayed.

Note:

*Other run parameters can be edited using the **Edit run** option available in the **Run view** screen.*

4

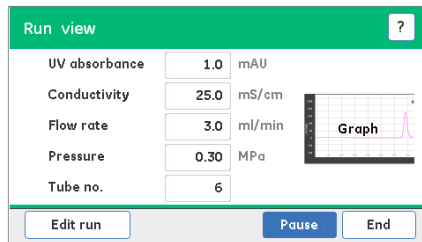

In the **Run view** screen, the following options are available to monitor and control the ongoing run (for details, see [Section 6.3.2 Monitor and control the run, on page 153](#)):

Step	Action
------	--------

Graph, to view the chromatogram.

Edit run, to change any run parameters in the current run.

Hold, to temporarily hold the run, with current set flow rate, valve positions and B concentration.

Pause, to pause the current run.

End, to end the run before it is completed.

Note:

The run begins with a default pump wash. Pump wash is performed at 10 ml/min for 1 min with 30 s of buffer B wash followed by 30 s of buffer A wash.

Edit run is disabled when the pump wash is in progress. During pump wash the flow is directed through **Wash valve** to **Waste**.

Note:

The USB memory stick stores the result files which can be viewed using UNICORN start. Also a BMP file is generated which can be viewed from any PC. For details, refer to Section 6.6.3 BMP result file, on page 196.

Do not remove the USB memory stick until the system generates the report.

Hold the run

Follow the instruction below to hold an ongoing run.

Step	Action
------	--------

1



In the **Run view**, tap **Hold** to temporarily hold the run.

Note:

Not applicable for a manual run. **Hold** option is active only in a method run.

6 Operation from the Instrument Display

6.4 Perform a method run

6.4.2 Quick start

Step	Action
------	--------

2



To resume the run, tap **Resume**.

Note:

During hold the run is temporarily interrupted. Flow continues at the current flow rate, but the current gradient concentration and valve positions are maintained.

6.4.3 Templates

Introduction

ÄKTA start provides four method templates based on the most commonly used purification techniques. The templates are provided with default run parameters. The parameters can also be changed to suit the run conditions. New methods can be created and saved from these predefined templates in the **Create method** option.

This section describes how to start a run using **Templates**.

Predefined method templates

The user can create customized purification methods based on the templates available on the instrument. The predefined templates available with ÄKTA start are described below.

Method	Description
<i>Affinity (AC)</i>	Affinity Chromatography separates molecules based on the reversible interaction between the target protein and the specific ligand attached to a chromatography matrix.
<i>Ion exchange (IEX)</i>	Ion Exchange Chromatography is based on the reversible interaction between a charged protein and an oppositely charged chromatography medium.
<i>Gel filtration (GF)</i>	Gel filtration, also known as size-exclusion chromatography, is a chromatography technique that separates molecules based on differences in the molecular size.
<i>Desalting/buffer exchange (DS)</i>	Desalting is a gel filtration technique that allows rapid group separation of high molecular weight substances from low molecular weight substances. Small molecules like salt, free labels and other impurities are efficiently separated from the high molecular weight substances of interest.

6 Operation from the Instrument Display

6.4 Perform a method run

6.4.3 Templates

Affinity (AC) or Ion exchange (IE)

Follow the instruction below to start a run based on **Affinity (AC)** or **Ion exchange (IEX)**.

Note: Make sure that a USB memory stick is connected to the instrument. If the instrument does not detect a USB memory stick, the result will not be saved.

Note: Before starting the run, set the status of the Fraction collector to enabled or disabled as required.

Step Action



In the **Method run** screen, tap **Templates** to access the different templates.

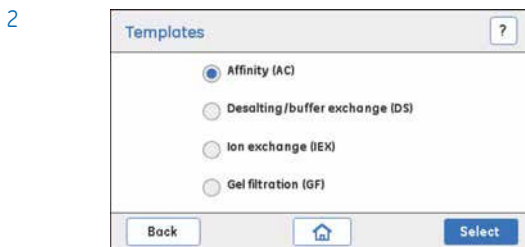

- Tap a radio button to select a template that suits your application.
- To continue with the selected technique, tap **Select**.

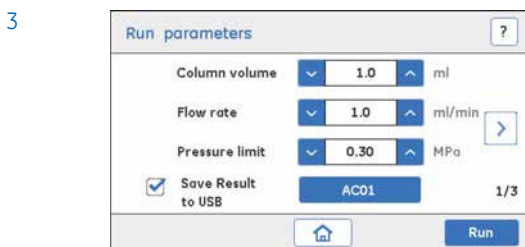

Step	Action
------	--------

- | | |
|--|---|
| | <ul style="list-style-type: none"> Set the run parameters: <ul style="list-style-type: none"> Column volume, column volume (ml) Flow rate, flow rate (ml/min) Pressure limit, pressure limit (MPa) Tick the checkbox Save Result to USB if you want to save the result. The result file name can be edited by setting the digits in the range 00 to 99. Tap the forward arrow to access additional run parameters. |
|--|---|

Note:

Make sure that the values for the **Column volume**, **Flow rate** and **Pressure limit** are appropriate for the chosen column. Refer to the column manual for details.

If the pressure reaches above the set limit, the instrument will enter the **Pause** state.

Note:

The USB memory stick stores the result files which can be viewed using UNICORN start. Also a BMP file is generated which can be viewed from any PC. For details, refer to Section 6.6.3 BMP result file, on page 196.

Do not remove the USB memory stick until the system generates the report (BMP file).

4

Run parameters		?
Sample from	<input checked="" type="radio"/> Pump <input type="radio"/> Loop	
Sample volume	0.1 ml	>
Equilibration volume	5.0 CV	
Wash unbound volume	15.0 CV	2/3
<input type="button" value="Home"/> <input type="button" value="Run"/>		

- Select the mode of sample injection in the **Sample from** field: to be applied via **Pump** or via **Loop**. For detailed instructions on sample application, refer to Section 5.7 Sample application, on page 123.

6 Operation from the Instrument Display

6.4 Perform a method run

6.4.3 Templates

Step	Action
------	--------

- Set the run parameters:
 - **Sample volume**, the volume of sample to be loaded onto the column
 - **Equilibration volume**, the volume of buffer A required for for equilibrating the column.
 - **Wash unbound volume**, volume of buffer needed after the sample application to wash off the unbound molecules

Note:

For AC/IEX methods when loading sample through loop it is advisable to empty the loop with 3 times the loop volume to achieve good sample recovery.

5

The screenshot shows the 'Run parameters' dialog box with the 'Isocratic' radio button selected. The parameters are: Conc B (100%), Elution volume (5.0 CV), and Fractionation volume (1.0 ml). A 'Run' button is visible at the bottom right.

- Configure the run parameters for **Elution Option** set as **Isocratic**:
 - **Conc B**, concentration of buffer B to elute the bound protein
 - **Elution volume**, volume needed to elute the bound protein from the column
 - **Fractionation volume**, volume of the fraction to be collected when the Fraction collector is enabled

or

The screenshot shows the 'Run parameters' dialog box with the 'Gradient' radio button selected. The parameters are: Target conc B (100%), Gradient volume (5.0 CV), and Fractionation volume (1.0 ml). A 'Run' button is visible at the bottom right.

Step	Action
------	--------

- | | |
|--|--|
| | <ul style="list-style-type: none"> Configure the run parameters for Elution Option set as Gradient (Bound proteins are eluted with continuous change of buffer B composition to increase eluent strength over specified time): <ul style="list-style-type: none"> - Target conc B, maximum buffer B concentration level to be set in the gradient - Gradient volume, volume needed to elute the bound protein from the column - Fractionation volume, volume of the fraction to be collected when the Fraction collector is enabled. Tap back arrow to view or edit run parameters. Tap Run to start the run. |
|--|--|

Result: The **Run view** screen will be displayed.

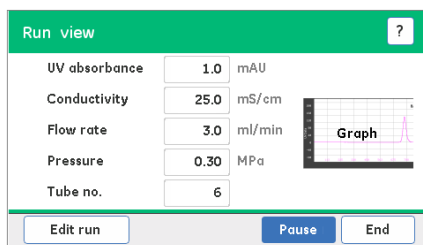
**Note:**

The run begins with a default pump wash. Pump wash is performed at 10 ml/min for 1 min with 30 s of buffer B wash followed by 30 s of buffer A wash.

Edit run is disabled when the pump wash is in progress. During pump wash the flow is directed through **Wash valve** to **Waste**.

Gel filtration, Desalting/Buffer Exchange

Follow the instruction below to start a run based on **Gel Filtration** or **Desalting** template.

Note: Make sure that a USB memory stick is connected to the instrument. If the instrument does not detect a USB memory stick, the result will not be saved.

Note: Before starting the run, set the status of the Fraction collector to enabled or disabled as required.

6 Operation from the Instrument Display

6.4 Perform a method run

6.4.3 Templates

Step	Action
------	--------

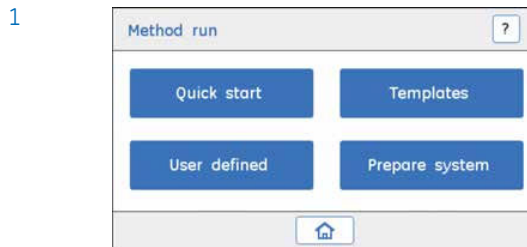

In the **Method run** screen, tap **Templates** to access the predefined method templates.

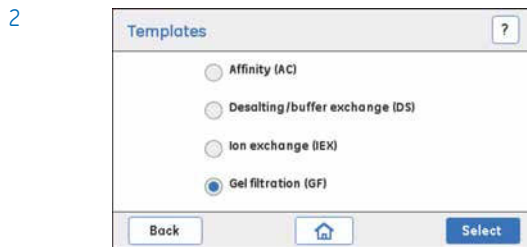

- Tap a radio button to select a template that suits your application (e.g., **Gel filtration**).
- To continue with the selected technique, tap **Select**.

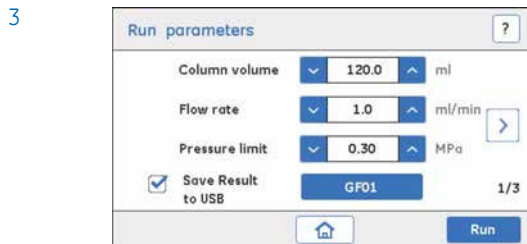

Step	Action
------	--------

- Set the run parameters:
 - **Column volume**, column volume (ml)
 - **Flow rate**, flow rate (ml/min)
 - **Pressure limit**, pressure limit (MPa)

Use up/down arrows to set the values, or use numpad to type in the values.

- Tick the checkbox **Save Result to USB** if you want to save the result. The result file name can be edited by setting the digits in the range 00 to 99.
- Tap the forward arrow to access additional run parameters.

Note:

Make sure that the values for the **Flow rate** and **Pressure limit** are appropriate for the chosen column. Refer to the column manual for details.

If the pressure reaches above the set limit, the instrument will enter the **Pause** state.

Note:

The USB memory stick stores the result files which can be viewed using UNICORN start. Also a BMP file is generated which can be viewed from any PC. For details, refer to Section 6.6.3 BMP result file, on page 196.

Do not remove the USB memory stick until the system generates the report (BMP file).

4

The screenshot shows the 'Run parameters' interface. At the top, there is a title bar with a question mark icon. Below it, the 'Sample from' field has two radio buttons: 'Pump' (selected) and 'Loop'. The 'Sample volume' field is a numeric input with up/down arrows, set to '0.1' with 'ml' units. The 'Equilibration volume' field is a numeric input with up/down arrows, set to '0.2' with 'CV' units. The 'Wash unbound volume' field is a numeric input with up/down arrows, set to '0.0' with 'CV' units. A '2/3' indicator is next to it. At the bottom, there is a home icon and a blue 'Run' button.

- Select the mode of sample injection in the **Sample from** field: to be applied via **Pump** or via **Loop**. For detailed instructions on sample application, refer to Section 5.7 Sample application, on page 123.
- Set the run parameters:
 - **Sample volume**, the volume of sample to be loaded in to the column
 - **Equilibration volume**, the volume of buffer A required for for equilibrating the column.

6 Operation from the Instrument Display

6.4 Perform a method run

6.4.3 Templates

Step	Action
------	--------

Note:

Washout unbound is not applicable for GF/DS methods.

Note:

Make sure to load the recommended sample volume for selected column.

If large GF columns are used, it is recommended to pre-equilibrate the column before starting the run.

5

The screenshot shows a 'Run parameters' screen with a question mark icon in the top right corner. On the left, there is a back arrow icon. The parameters are: 'Conc B' with a value of '0' and a '%' unit; 'Elution volume' with a value of '1.0' and a 'CV' unit; and 'Fractionation volume' with a value of '4.0' and a 'ml' unit. To the right of the fractionation volume, it says '3/3'. At the bottom, there is a home icon and a blue 'Run' button.

- Set the run parameters:
 - **Elution volume**, volume of buffer needed to elute the protein from the column
 - **Fractionation volume**, volume of fractions to be collected when the Fraction collector is enabled.
- Tap **Run** to start the run.

Result: The **Run view** screen will be displayed.

Note:

Conc B is not applicable for GF/DS as elution takes place only with a single buffer (buffer A).

Note:

The run begins with a default pump wash. Pump wash is performed with buffer A at 10 ml/min for 30 s.

Edit run is disabled when the pump wash is in progress. During pump wash the flow is directed through **Wash valve** to **Waste**.

6.4.4 User defined methods

Start a run

Follow the instruction below to start a run based on a user created or USB imported method.

Note: *Make sure that a USB memory stick is connected to the instrument. If the instrument does not detect a USB memory stick, the result will not be saved.*

Step	Action
------	--------

1

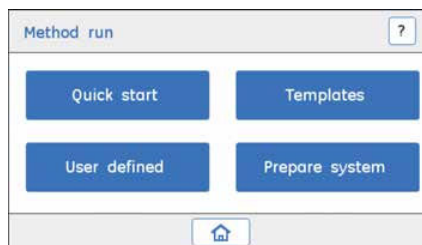

In the **Method run** screen, tap **User defined** to access the user created methods.

2

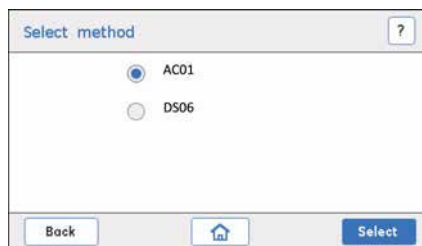

- Tap a radio button to select a user method to run.
- To continue with the selected user method, tap **Select**.

3

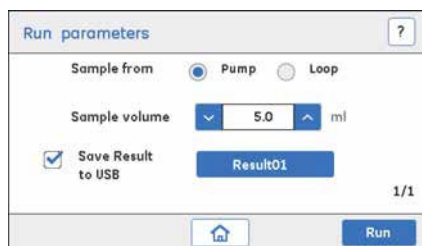

6 Operation from the Instrument Display

6.4 Perform a method run

6.4.4 User defined methods

Step	Action
------	--------

Set the run parameters:

- Select the mode of sample injection in the **Sample from** field: to be applied via **Pump** or via **Loop**. For detailed instructions on sample application, refer to *Section 5.7 Sample application, on page 123*.
- **Sample volume**, the volume of sample to be loaded in to the column
- Tick the checkbox **Save Result to USB** if you want to save the result. The result file name can be edited by setting the digits in the range 00 to 99.
- Tap **Run** to start the selected method.

Result: The **Run view** screen will be displayed.

4

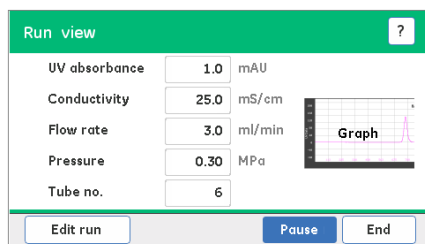

In the **Run view** screen, the following options are available to monitor and control the ongoing run (for details, see *Section 6.3.2 Monitor and control the run, on page 153*):

Graph, to view the chromatogram.

Edit run, to change any run parameters in the current run.

Hold, to hold the current run.

Pause, to pause the current run.

End, to end the run before it is completed.

Note:

The USB memory stick stores the result files which can be viewed using UNICORN start. Also a bmp file is generated which can be viewed from any PC. For details, refer to Section 6.6.3 BMP result file, on page 196.

Do not remove the USB memory stick until the system generates the report (.bmp file).

Note:

USB imported methods which were created in UNICORN start cannot be edited in the instrument. Use UNICORN start to edit those methods.

6.4.5 Prepare system methods

Introduction

Predefined methods for the preparation and the cleaning of the system are available with ÄKTA start. Use the **Prepare system** methods to clean the entire system flow path when needed, and to fill the system with storage solution when the instrument is not going to be used for a period of time. For detailed instructions, see *Section 8.3 Cleaning the system flow path, on page 210*.

The system methods available with ÄKTA start are listed below:

- **Pump wash A**
- **Pump wash B**
- **Washout fractionation tubing**
- **Column preparation**
- **System cleaning**
- **System performance method**

The **Pump wash A/B**, **Washout fractionation tubing**, and **Column preparation** methods required for the system preparation are presented in detail in *Section 5.6 System methods for run preparation, on page 113*. The **System performance method** is presented in *Section 5.4 System performance, on page 95*.

System cleaning

Follow the instruction below to perform a system cleaning run. For detailed instructions on cleaning the system using the **System cleaning** template, see *Section 8.3.2 System cleaning, on page 213*.

Step	Action
------	--------

1



In the **Method run** screen, tap **Prepare system** to access the system methods.

6 Operation from the Instrument Display

6.4 Perform a method run

6.4.5 Prepare system methods

Step	Action
------	--------

2

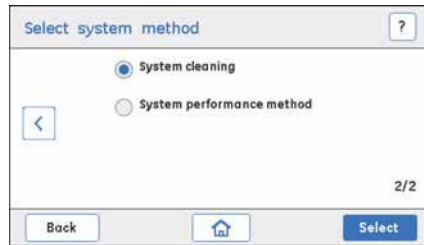

In the **Select system method** screen,

- Select **System cleaning**.
- To continue with the **System cleaning** method, tap **Select**.

3

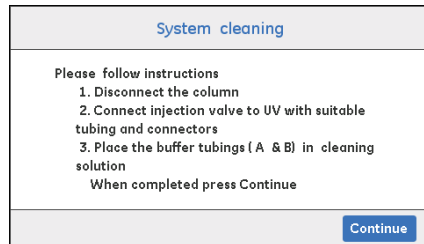

- Perform the operations described on the display:
 - 1 Disconnect the column.
 - 2 Connect **Injection valve** to **UV** with suitable tubing and connectors.
 - 3 Place the buffer tubings (A & B) in cleaning solution.For detailed instructions, see *Section 8.3.2 System cleaning, on page 213*.
- Tap **Continue** to start the **System cleaning** run.

Step Action

4



Wait for the run to complete.

Note:

If required, the **System cleaning** run can be ended before it completes by tapping **End**.

5



Tap **Exit** to close the **System cleaning** screen when the **System cleaning** run is completed.

6.5 Procedures after a run

Introduction

This section briefly describes:

- How to evaluate a recorded result
- How to clean the instrument after a run.
- How to prepare the system for storage if the instrument is not going to be used for a period of time.

The instrument and the columns should be cleaned between the runs. This will prevent, for example, carryover and cross-contamination among samples, protein precipitation, and clogging of the column or flow path. For further details on cleaning and maintenance procedures, see *Chapter 8 Maintenance, on page 205*.

Evaluate a run

After a chromatographic run, the result stored on a USB memory stick can be transferred to UNICORN start where it can be viewed, and evaluated. The result holds a complete record of the run, including method, system settings, chromatogram, and run log. The result can be also viewed by using the BMP result file that is generated and stored on the USB memory stick. For details, refer to *Section 6.6.3 BMP result file, on page 196*.

Detailed instructions for the transfer of the result are presented in *Section 6.6 Manage methods and files, on page 183*.

Detailed instructions for the evaluation of a result are presented in *Chapter 7 Operation from UNICORN start, on page 198*, and in the *UNICORN start User Manual*.

Clean the system

After a run is completed, perform the following:

- Remove the column from the flow path and re-connect the flow path. For detailed instructions, see *Section 8.3.1 Disconnect the column, on page 212*.
- Rinse the flow path with cleaning solution and/or DM water using either **System cleaning** or the **Pump wash** methods, as required. For detailed instructions, see *Section 8.3 Cleaning the system flow path, on page 210*.
- If required, remove the tubes from the Fraction collector. If there is any spillage, clean the Bowl assembly with DM water.
- Clean all spills on the instrument and on the bench using a damp cloth.

- Empty the waste container.
-

Clean and store the column

After a run is completed, perform the following:

- Disconnect the column from the flow path.
- Clean the column off-line according to the column instructions.

If the column is not going to be used for a couple of days or longer, perform the following:

- Fill the column with the storage solution recommended in the column data sheet.
 - Detach the column from the instrument and store it according to the column recommendation.
-

System storage

If the instrument is not going to be used for a period of time, fill the system and the inlets with storage solution (DM water or 20% ethanol). For detailed instructions, see *Section 8.8 Storage of the instrument, on page 228*.

Power off the instrument

Switch off the instrument by turning the Power switch to the **O** position.



Note: *When the instrument is switched off or not in use, make sure to open the pump hood and release the pump tubing from the pump head.*

6.6 Manage methods and files

Introduction

This section describes how to create, edit, import and delete methods on ÄKTA start. For information about how to create a method using the UNICORN start, see *Chapter 7 Operation from UNICORN start, on page 198* or the *UNICORN start User Manual*.

In this section

This section contains the following subsections:

Section	See page
6.6.1 Create method	184
6.6.2 Handling the USB memory stick	193
6.6.3 BMP result file	196

6 Operation from the Instrument Display

6.6 Manage methods and files

6.6.1 Create method

6.6.1 Create method

Create method menu

The **Create method** menu allows the user to create a new method, edit, import, and delete a method from the ÄKTA start Instrument Display.

Follow the instructions below to access the **Create method** options.

Step	Action
------	--------

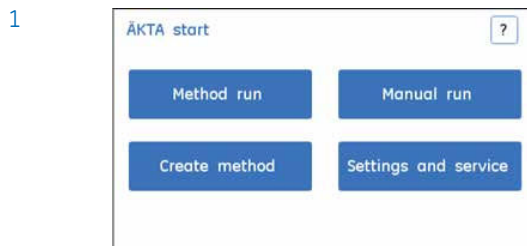

In the **ÄKTA start** home screen, tap **Create method**.



In the **Create method** screen, the following options are available:

Create, to create a new method using a predefined template

Edit, to edit a method or change run parameters for user created methods stored on instrument

USB Import, to import a method developed on UNICORN start to the instrument using a USB memory stick

Delete, to delete a method that is stored on the instrument

Create a method

Follow the instruction below to create a method using a predefined template.

Step	Action
------	--------

1



In the **Create method** screen, tap **Create**.

Result: The **Select templates** screen opens.

2

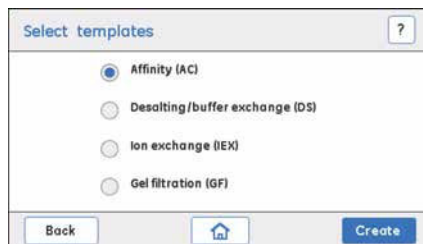

- Tap a radio button to select a template.
- Tap **Create** to create a method based on the selected technique.

For details on the templates available in ÄKTA start, refer to *Section 6.4.3 Templates, on page 167*.

3

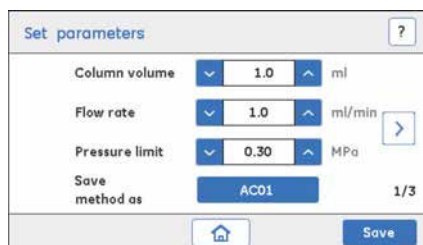

- Set the run parameters:
 - **Column volume**, column volume (ml)
 - **Flow rate**, flow rate (ml/min)
 - **Pressure limit**, pressure limit (MPa)

6 Operation from the Instrument Display

6.6 Manage methods and files

6.6.1 Create method

Step	Action
------	--------

- Select **Save Method as** field if you want to set a method name. The file name can be edited by setting the digits in the range 00 to 99.

Note:

Provide a unique method name. The created method will be saved under the **User defined** methods menu.

Note:

Make sure that the values for the **Column volume**, **Flow rate** and **Pressure limit** are appropriate for the chosen column. Refer to the column manual for details.

If the pressure reaches above the set limit, the instrument will enter the **Pause** state.

4

- Select the mode of sample injection in the **Sample from** field: to be applied via **Pump** or via **Loop**. For detailed instructions on sample application, refer to *Section 5.7 Sample application, on page 123*.
- Set the run parameters:
 - **Sample volume**, the volume of sample to be loaded onto the column
 - **Equilibration volume**, the volume of buffer A required for equilibrating the column
 - **Wash unbound volume**, volume of buffer needed after the sample application to wash off the unbound molecules

Note:

The **Washout unbound volume** is applicable only for AC/IEX techniques.

Step	Action
------	--------

5

Set parameters		?
Elution option	<input checked="" type="radio"/> Isocratic <input type="radio"/> Gradient	
Conc B	100 %	
Elution volume	5.0 CV	
Fractionation	1.0 ml	3/3
<input type="button" value="Home"/> <input type="button" value="Save"/>		

- Configure the run parameters for **Elution Option** set as **Isocratic**:
 - **Conc B**, concentration of buffer B to elute the bound protein
 - **Elution volume**, volume needed to elute the bound protein from the column
 - **Fractionation volume**, volume of the fraction to be collected when the Fraction collector is enabled

or

Set parameters		?
Elution option	<input type="radio"/> Isocratic <input checked="" type="radio"/> Gradient	
Target conc B	100 %	
Gradient volume	5.0 CV	
Fractionation	1.0 ml	3/3
<input type="button" value="Home"/> <input type="button" value="Save"/>		

- Configure the run parameters for **Elution Option** set as **Gradient** (Bound proteins are eluted with continuous change of buffer B composition to increase eluent strength over specified time):
 - **Target conc B**, maximum buffer B concentration level to be set in the gradient
 - **Gradient volume**, volume needed to elute the bound protein from the column
 - **Fractionation volume**, volume of the fraction to be collected when the Fraction collector is enabled.
- Tap **Save** to save the new method.

Result: A **Message** screen that requires to confirm the action will be displayed.

6 Operation from the Instrument Display

6.6 Manage methods and files

6.6.1 Create method

Step	Action
------	--------

6



Tap **Yes** to confirm the saving of the method or tap **No** to cancel the action and return to set the run parameters.

Note:

The created method will be saved under the **User defined** methods menu.

The system can store up to 10 methods only. Delete existing methods if new methods need to be stored.

Edit a method

Follow the instructions below to edit a user defined method.

Step	Action
------	--------

1



In the **Create method** screen, tap **Edit** to access the methods.

Result: The **Select method to edit** screen opens.

Step	Action
------	--------

2

- In the **Select method to edit** screen, tap a radio button to select a user method.
- Tap **Edit** to start editing the run parameters for the selected method.

3

6 Operation from the Instrument Display

6.6 Manage methods and files

6.6.1 Create method

Step	Action
------	--------

- | | |
|--|---|
| | <ul style="list-style-type: none">Select Save Method as field if you want to set a method name. The file name can be edited by setting the digits in the range 00 to 99. |
|--|---|

Note:

Provide a unique method name, for example AC02, DS05. The created method will be saved under the **User defined** methods menu.

USB imported methods which were created using UNICORN start cannot be edited from the instrument. Use UNICORN start to edit those methods.

4



Tap **Yes** to confirm the saving of the method

or

Tap **No** to cancel the action and return to set the run parameters.

Import a method

Follow the instruction below to import a method stored on a USB memory stick.

Note: Make sure that the USB memory stick containing the user defined methods is connected to the instrument. For details about exporting a method, see Section 6.6.2 Handling the USB memory stick, on page 193.

Step	Action
------	--------

1

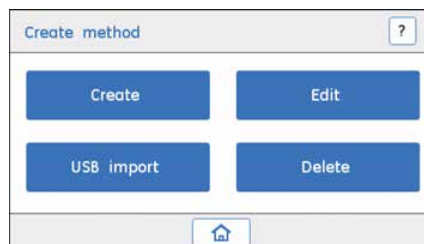

In the **Create method** screen, tap **USB Import** to access the methods.

Step	Action
------	--------

2



- Tap a radio button to select a method.
- Tap **Import** to import the method.

Result: A **Message** screen that requires to confirm the action will be displayed.

3



Tap **Yes** to confirm the import of the selected file

or

Tap **No** to cancel the action and return to the file list.

Note:

*The imported methods will be saved under the **User defined** methods menu. Only one method can be imported at a time. If multiple methods are to be imported, repeat the steps described above.*

Note:

If the system memory is full, delete existing methods before importing a new method.

6 Operation from the Instrument Display

6.6 Manage methods and files

6.6.1 Create method

Delete a method

Follow the instruction below to delete a user method.

Step	Action
------	--------



In the **Create method** screen, tap **Delete** to access the methods.

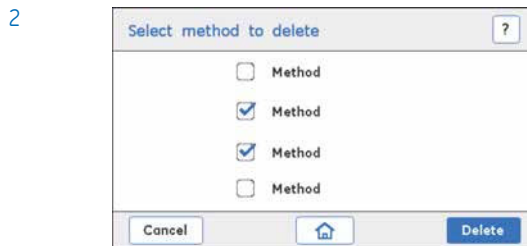

- Tap a checkbox to select a method.
- Tap **Delete** to delete the method.
*Result: A **Message** screen that requires to confirm the action opens.*
or
To cancel the action and return to the **Create method** screen, tap **Cancel**.

Note:

Multiple files can be deleted at the same time.

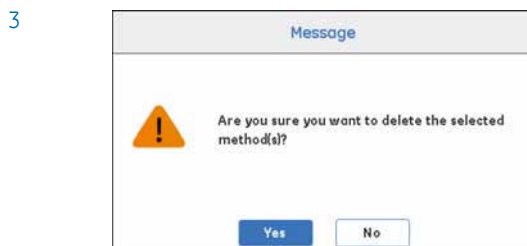

Tap **Yes** to confirm the deletion of the selected files or tap **No** to cancel the action and return to the file list.

6.6.2 Handling the USB memory stick

Introduction

ÄKTA start provides the user with the option to store result data on a USB memory stick. The USB memory stick is used to save a result, BMP file and also for transferring methods between the instrument and UNICORN start. The USB memory stick is also used to generate a System error report.

- Note:**
- *The result files will be saved in the GE folder which is automatically created by the instrument when the USB memory stick is first plugged in.*
 - *At any given point of time only 10 results can be stored in the GE folder. To save further results, transfer the result files to another folder, PC or rename the GE folder.*
-

Store result on a USB memory stick

Follow the instructions below to store results generated in ÄKTA start on a USB memory stick.

Step	Action
1	Connect a USB memory stick to the instrument, via the USB port.
2	Start a Manual run or Method run .
3	In the Run parameters screen, tick the Save results to USB check box in order to save the generated results on the USB memory stick. When the run is complete, the results are saved in a GE folder.
4	A BMP result file is also generated. Hence, the chromatogram can be viewed without the use of UNICORN start.
5	Export the results to UNICORN start to view the chromatogram and evaluate.

- Note:** *Make sure that the USB memory stick is not removed during the run. For more details, see Do's and Don't's while handling the USB memory stick, on page 194.*
-

6 Operation from the Instrument Display

6.6 Manage methods and files

6.6.2 Handling the USB memory stick

Do's and Dont's while handling the USB memory stick

- Make sure that the USB memory stick is inserted completely into the instrument.
 - The maximum supported USB memory stick capacity is 32 GB. A minimum of 1 GB free space is required to execute read/write operations.
 - Only FAT32 file system is supported and this needs to be taken into account when formatting the memory stick.
 - Only unplug the USB memory stick when the instrument display is in the Home screen.
 - It is preferred to keep a minimum number of files on the memory stick. Once you take a backup of the files, delete them from the memory stick and then save onto a computer. Avoid keeping unnecessary files in the memory stick.
 - Avoid using folders named GE on the USB memory stick. However, you may use folders named for example GE_ or GExyz.
 - Always take backup of complete GE folder from USB memory stick and do not backup individual files. It is recommended to take backups whenever you have completed important runs.
-

Result file import from USB stick to UNICORN start

Follow the instructions below to export a result file generated in ÄKTA start, and import it into UNICORN start.

Step	Action
1	Open the Evaluation module in UNICORN start.
2	Select File:Import:Import ÄKTA start results from USB... , and then import the result files to a desired location on the computer.
3	View, analyze, report or print the result file.

Method Export from UNICORN start to USB memory stick

Follow the instructions below to export a method created in UNICORN start, to a USB memory stick.

Step	Action
1	Create a method using the Method Editor module in UNICORN start.

Step	Action
2	Connect a USB memory stick to the computer.
3	Select File:Export:Export Method... in order to export the created method to a USB memory stick, connected to the computer.
	Note: <i>Make sure that the method is stored in a GE folder.</i>

Method Import to ÄKTA start – USB import

Follow the instructions below to import a method from UNICORN start, to ÄKTA start.

Step	Action
1	Create a method using the Method Editor module in UNICORN start.
2	Select File:Export:Export Method for ÄKTA start to USB... in order to export the created method to a USB memory stick.
3	Connect the USB memory stick to ÄKTA start.
	Note: <i>Make sure that the method is stored in a GE folder.</i>
4	From the ÄKTA start Home screen, tap Create method : USB import .
5	Select the method to import.

6.6.3 BMP result file

Introduction

In order to provide the user with the option to view the result image using another type of software outside of ÄKTA start and UNICORN start, the instrument provides the feature to export the result in BMP format. This format facilitates viewing of the generated result without UNICORN start.

Features of the exported result

- The result file is a graphics file in BMP format, compatible with Microsoft® Windows® and Macintosh™ operating systems.
 - The BMP result is saved and exported, if user selects the option to **Save result to USB** before the start of a run.
 - The result file contains the UV curve data with fractionation marks.
 - The result file contains up to 4 hours of run data. For longer runs, the last 4 hours are saved.
 - The BMP file displays the necessary legends like Product name, run details, UV, Frac marks.
 - The result file is saved if the user terminates the run before completion. However, no file is saved in the event of shutdown or power failure.
-

Exporting results

Step	Action
------	--------

- | | |
|---|--|
| 1 | Connect a USB memory stick to the instrument. |
| 2 | Start a Method run or Manual run . |

Step **Action**

- 3 Tick the **Save results to USB** check box in order to save the results to the USB memory stick.

Note:

The results will not be saved if this option is not checked.

Note:

A BMP file is only generated when the result is saved.

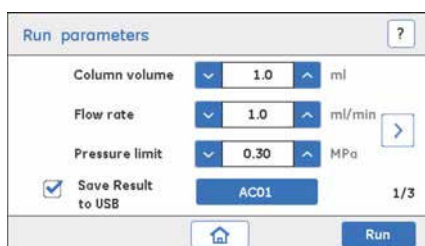

Run parameters

Column volume: 1.0 ml

Flow rate: 1.0 ml/min

Pressure limit: 0.30 MPa

Save Result to USB

ACQ1 1/3

Run

- 4 When the run is completed, the result will be saved and a BMP file will be generated.

Note:

Do not unplug the USB memory stick when the BMP file generation is in progress.

- 5 Transfer and connect the USB memory stick to a computer. Open the BMP file to view or print the result.

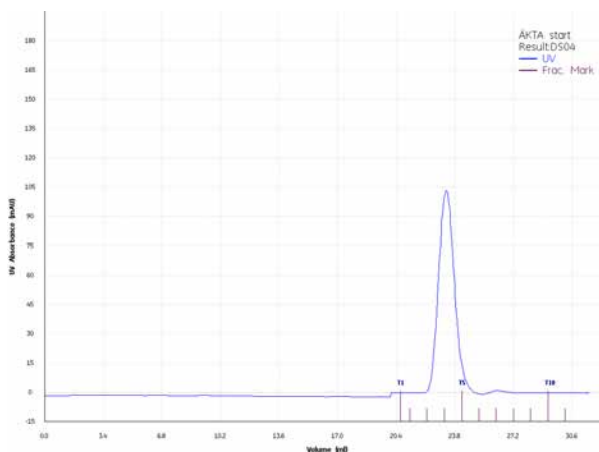

7 Operation from UNICORN start

About this chapter

This chapter gives a brief description of the four modules of UNICORN start: **System Control**, **Method Editor**, **Evaluation** and **Administration**. For more details, refer to the *UNICORN start User Manual*.

In this chapter

This chapter contains the following sections:

Section	See page
7.1 System Control	199
7.2 Method Editor	201
7.3 Evaluation	203
7.4 Administration	204

Introduction

UNICORN start offers the following functions:

- Simple and flexible method creation.
 - Easy system control using process picture and real time monitoring of manual and method runs.
 - Ability to evaluate and compare results.
 - Create and print PDF reports.
 - Ability to manage (store, archive/retrieve, backup/restore) results generated from ÄKTA start.
-

7.1 System Control

Introduction

The **System Control** module is used to start, view, and control a run.

Illustration of the **System Control** user interface

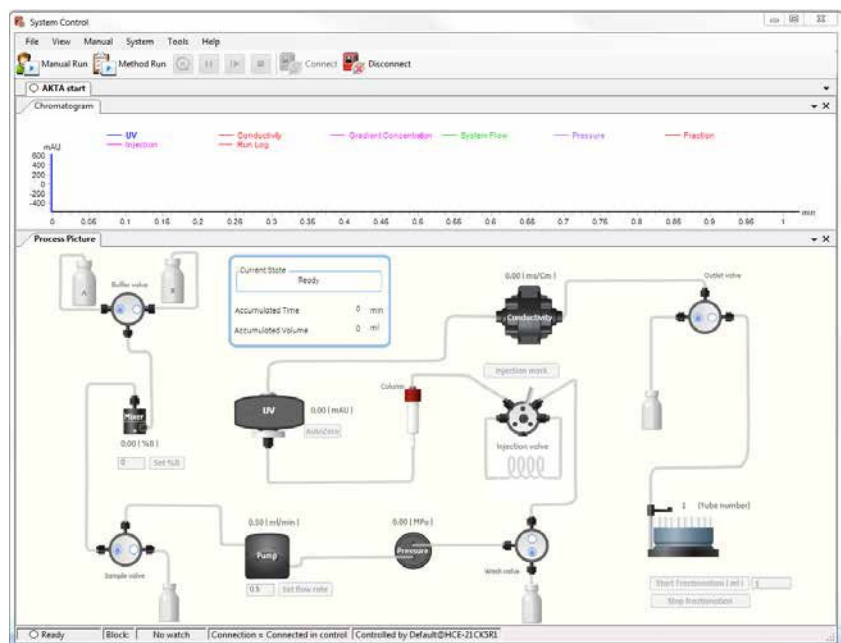

Main features

The main features of the **System Control** module are listed below:

- A flow scheme representing the real time flow path with indications of the different modules on the wet side of the instrument. Current run status of the system is displayed.
- The ability to control the instrument by clicking on the flow path, for example, to turn the valves, set flow rates, change B concentrations and start/stop fractionation.

7 Operation from UNICORN start

7.1 System Control

- A real time chromatogram depicting the complete run with curves including UV, conductivity, system flow, gradient concentrations, fraction marks, run logs and pressure.
- The ability to perform manual and method runs.
- Ability to run predefined methods like **Quick start**, **Templates** and **Prepare system methods**.
- Ability to perform **System performance method**.
- Ability to generate a System error report.

Note: *When the Fraction collector is enabled, the process picture will display a Fraction collector image. If the Fraction collector is disabled, a collection beaker image is displayed.*

7.2 Method Editor

Introduction

The **Method Editor** module provides flexibility to create or edit the chromatography methods.

Illustration of the **Method Editor** module

The user interface of **Method Editor** is illustrated below.

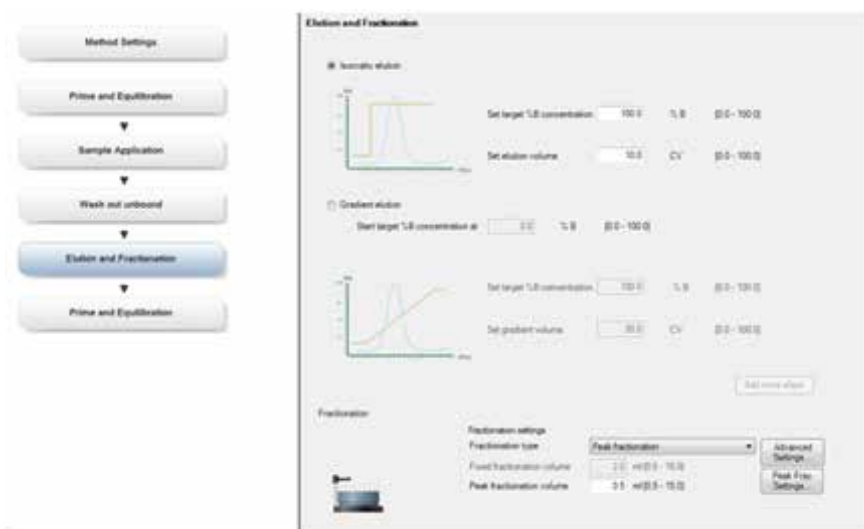

Main features

The main features of the **Method Editor** module are listed below:

- Ability to create methods from predefined templates like **Affinity**, **Ion Exchange**, **Desalting** and **Gel Filtration**.
- Flexibility to create customized methods by dragging and dropping chromatography phases such as **Prime and Equilibration**, **Sample Application**, **Wash Out Unbound**, **Elution and Fractionation**.

7 Operation from UNICORN start

7.2 Method Editor

- The methods created from **Method Editor** can either be run directly from **System Control** or exported to a USB memory stick to run them from ÄKTA start directly.
-

7.3 Evaluation

Introduction

The **Evaluation** module is used to manage and evaluate the results from chromatography runs.

Illustration of the **Evaluation** module

The user interface of **Evaluation** is illustrated below.

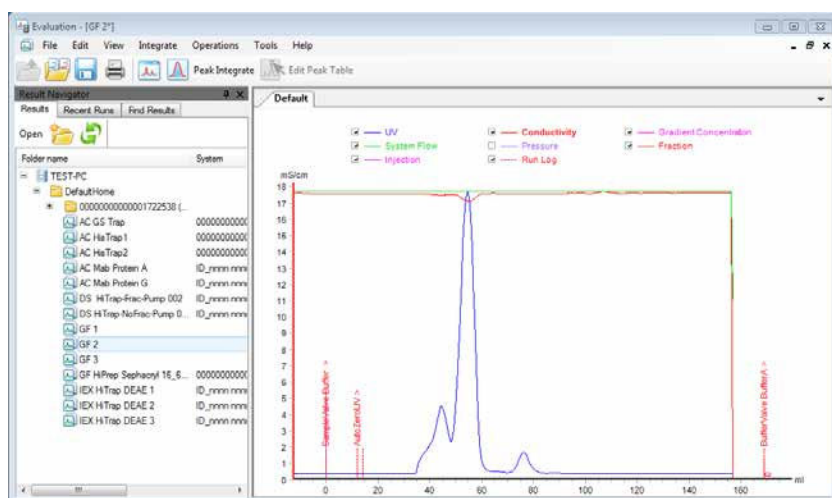

Main features

The main features of the **Evaluation** module are listed below:

- Open and view existing chromatogram results.
- Compare two curves or chromatograms.
- Perform peak integration analysis.
- Create and print PDF reports.
- Import results from ÄKTA start via a USB memory stick.

7.4 Administration

Introduction

The **Administration** module is used to manage the UNICORN start database and to review UNICORN start and system logs.

Illustration of the *Administration* module

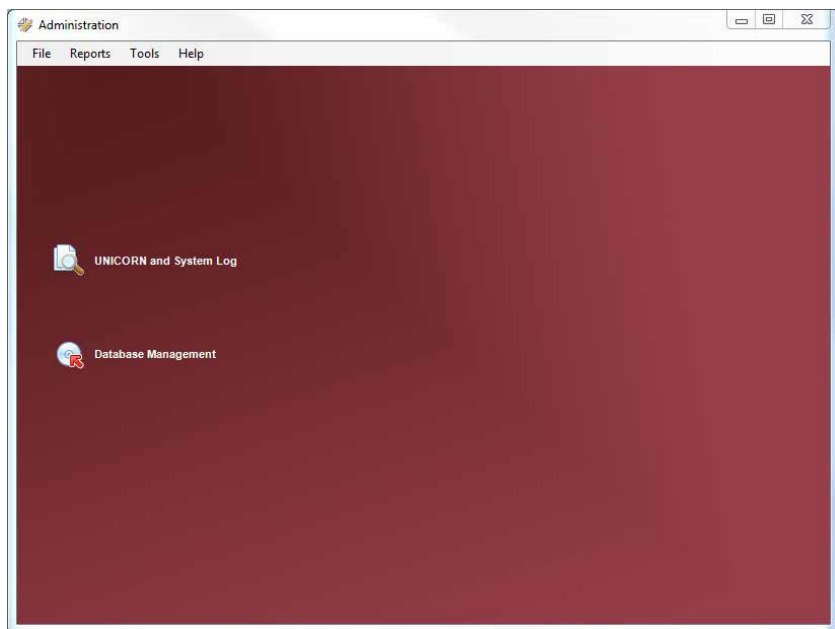

Main features

The main features of the **Administration** module are listed below:

- Ability to back up/restore and archive/retrieve files.
 - Review the UNICORN start and system logs.
-

8 Maintenance

About this chapter

This chapter describes cleaning and storage procedures and replacement of tubing and filters. For other maintenance procedures, refer to the *ÄKTA start Maintenance Manual*.

In this chapter

This chapter contains the following sections:

Section	See page
8.1 Regular maintenance schedule	206
8.2 Cleaning before planned maintenance/service	209
8.3 Cleaning the system flow path	210
8.4 Cleaning the UV flow cell	216
8.5 Cleaning the Conductivity flow cell	218
8.6 Cleaning the valves	219
8.7 Other cleaning procedures	222
8.8 Storage of the instrument	228
8.9 Replacement of tubing and filters	230

8.1 Regular maintenance schedule

Introduction

Regular maintenance should be performed on a daily, weekly and monthly basis. For cleaning instructions, refer to *ÄKTA start Operating Instructions*.

Daily maintenance

The following maintenance operations should be performed daily when the system is in use.

Maintenance action	See section
<p>Visually inspect the instrument for leakages in the flow path.</p> <p>Check the Pump for leakage. If there are signs of liquid leaking from the Pump, check the integrity of the pump tubing and the tubing connections.</p> <p>Note: <i>Make sure that the pump tubing is not left inside the Pump when it is not in use.</i></p>	-
<p>Clean the column and the system flow path after use and leave the system filled with DM water.</p> <p>Note: <i>If the instrument is not going to be used for a few days, prepare the system for storage.</i></p>	<p><i>Section 6.5 Procedures after a run, on page 180</i></p> <p><i>Section 8.3 Cleaning the system flow path, on page 210</i></p>
<p>Clean the valves (at least with DM water), after every run, or at the end of the day, or while leaving the instrument idle for several days to avoid salt crystal formation.</p> <p>Note: <i>If more thorough cleaning is required, 1 M NaOH may be used. After using NaOH for cleaning make sure to wash the flow path thoroughly with DM water before starting a run.</i></p>	<i>Section 8.6 Cleaning the valves, on page 219</i>

Weekly maintenance

The following maintenance operations should be performed weekly or when required.

Maintenance action	See section
Calibrate the Pump .	ÄKTA start Maintenance Manual
Visually inspect the inlet filters and clean them if necessary.	Section 8.7.1 <i>Cleaning the inlet filters, on page 223</i>

Monthly maintenance

The following maintenance operations should be performed monthly or when required.

Maintenance action	See section
Clean the system flow path with 1 M NaOH and rinse with DM water. Note: <i>Cleaning may be necessary more or less frequently, depending on the system usage and the nature of the samples.</i>	Section 8.3.2 <i>System cleaning, on page 213</i>
Visually inspect the drive sleeve on the Fraction collector. Replace if worn out.	ÄKTA start Maintenance Manual

Other maintenance

The following maintenance operations should be performed when required.

Maintenance action	See section
Clean the instrument externally	Section 8.7.2 <i>Cleaning the instrument externally, on page 224</i>
Clean the Fraction collector	Section 8.7.3 <i>Cleaning the Fraction collector, on page 225</i>
Perform System cleaning	Section 8.3.2 <i>System cleaning, on page 213</i>
Clean the UV flow cell	Section 8.4 <i>Cleaning the UV flow cell, on page 216</i>

8 Maintenance

8.1 Regular maintenance schedule

Maintenance action	See section
Clean the Conductivity cell	<i>Section 8.5 Cleaning the Conductivity flow cell, on page 218</i>
Calibrate the touch screen	<i>ÄKTA start Maintenance Manual</i>
Calibrate the UV flow cell	<i>ÄKTA start Maintenance Manual</i>
Calibrate the Conductivity cell	<i>ÄKTA start Maintenance Manual</i>
Pressure sensor zero offset	<i>ÄKTA start Maintenance Manual</i>
Replace the inlet filters	<i>Section 8.9.1 Replace the inlet filters, on page 231</i>
Replace the tubing and connectors	<i>Section 8.9.2 Replace the tubing and connectors, on page 232</i>

8.2 Cleaning before planned maintenance/service

Cleaning before planned maintenance/service

To ensure the protection and safety of service personnel, all equipment and work areas must be clean and free of any hazardous contaminants before a Service Engineer starts maintenance work.

Please complete the checklist in the *On Site Service Health & Safety Declaration Form*, or the *Health & Safety Declaration Form for Product Return or Servicing*, depending on whether the instrument is going to be serviced on site or returned for service, respectively. Copy the form you need from *Section 10.4 Health and Safety Declaration Form, on page 262* or print it from the PDF file available on the User Documentation CD.

8.3 Cleaning the system flow path

Introduction

Cleaning the system flow path is performed to prevent carryover between runs, contamination in the flow path and as a routine maintenance protocol.

Cleaning the system flow path is usually performed by using **System cleaning** or **Pump wash** methods.

Note: *Before cleaning the system flow path, remove the column from the flow path. For detailed instructions, see Section 8.3.1 Disconnect the column, on page 212.*



WARNING

Hazardous biological agents during run. When using hazardous biological agents, run the **System cleaning** method to flush the entire system tubing with 1 M NaOH and subsequently with distilled water, before service and maintenance.

NaOH is corrosive and therefore dangerous to health. When using hazardous chemicals, avoid spillage and wear protective glasses and other suitable Personal Protective Equipment (PPE).



CAUTION

Hazardous substances. When using hazardous chemical and biological agents, take all suitable protective measures, such as wearing protective glasses and gloves resistant to the substances used. Follow local and/or national regulations for safe operation, maintenance and decommissioning of the equipment.

Tip: *If hazardous chemicals are used for system or column cleaning, wash the system or columns with a non-hazardous solution in the last phase or step.*

In this section

This section contains the following subsections:

Section	See page
8.3.1 Disconnect the column	212

Section	See page
8.3.2 System cleaning	213

8.3.1 Disconnect the column

Introduction

The column should be removed from the flow path before cleaning the system flow path. The flow path has to be re-connected between the manual **Injection valve** port 1 and the **UV** inlet.

For column cleaning procedures and storage instructions, refer to the column catalogue.

Instruction

Follow the instructions below to remove the column and re-connect the flow path.

- | Step | Action |
|------|--|
| 1 | Disconnect the tubing from the column, as indicated by the arrows in the illustration below (1). |
| 2 | Re-connect the flow path between the Injection valve and the UV Monitor, as indicated by the arrows in the illustration below (2). Join the tubing by using the union mounted on the tubing connected to the UV flow cell . |

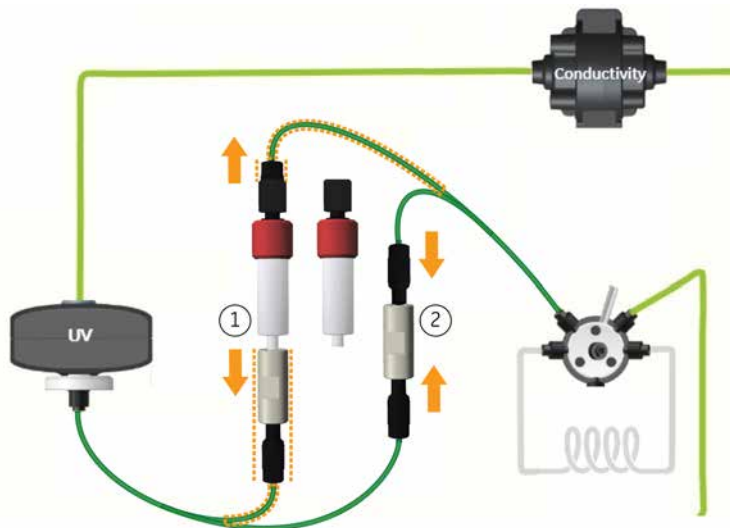

8.3.2 System cleaning

Introduction

The **System cleaning** method is used to clean the instrument flow path. **System cleaning** is recommended to be performed to prevent carryover between runs, contamination in the flow path, as a routine maintenance protocol and to prepare system for storage.

- Note:**
- *Cleaning is important for preventing cross-contamination and bacterial growth in the instrument.*
 - *Prepare cleaning solutions of recommended concentration to ensure proper cleaning.*
 - *It is recommended not to end the run before completion.*
 - *It is recommended to clean the inlets and outlets (sample tubing, fractionation tubing) from the **Edit run** screen.*
-

Required solutions

The following cleaning solutions are required:

- 1 M NaOH
 - DM water
-

Instruction

Follow the instructions below to clean the system flow path. The **System cleaning** procedure is initiated from the Instrument Display.

Step	Action
1	Remove the column from the flow path and re-connect the tubing.
2	Immerse both the buffer inlets in 1 M NaOH.
3	In the ÄKTA start home screen, tap Method run .

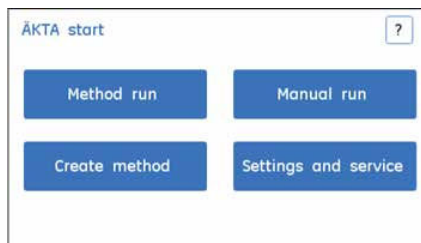

Step	Action
------	--------

4 In the **Method run** screen, tap **Prepare system**.



5 Select **System cleaning** and then tap **Select** to initiate the method. For detailed instructions, see Section 6.4.5 *Prepare system methods*, on page 177.

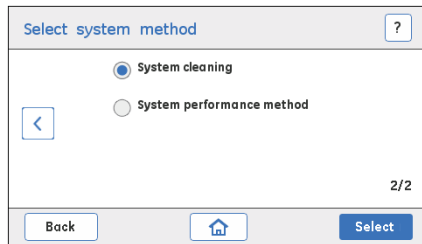

- 6
- Perform the operations presented on the display:
 - 1 Disconnect the column if this has not already been done (see Section 8.3.1 *Disconnect the column*, on page 212).
 - 2 Connect **Injection valve** to **UV** with suitable tubing and connectors.
 - 3 Place the buffer tubings (A & B) in cleaning solution.
 - Tap **Continue** to start **System cleaning**.

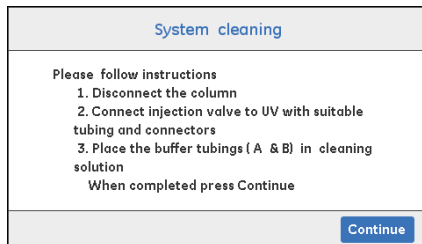

Step **Action**

- 7 When the run is completed, tap **End** to close the **System cleaning** screen.



- 8 Wash the complete flow path with water to remove NaOH from the system. Check the pH after washing with water to make sure that all NaOH is removed.

8.4 Cleaning the UV flow cell

Maintenance interval

Clean the **UV flow cell** every six months, or when required. A clean flow cell is essential for correct performance of the **UV Monitor**.



NOTICE

Keep UV flow cell clean. Do not allow solutions containing dissolved salts, proteins or other solutes to dry out in the **UV flow cell**. Do not allow particles to enter the **UV flow cell**, as damage to the flow cell may occur.

Required solutions

The following solutions are required:

- Cleaning solution: 10% detergent solution, such as Decon™ 90, Deconex™ 11, RBS 25, 1 M HCl or 1 M NaOH.
- DM water

- Note:**
- *It is recommended to use 10% detergent solution for cleaning the **UV flow cell**.*
 - *Heat the 10% detergent solution to 40°C to increase the cleaning efficiency.*
 - *If NaOH is used, perform cleaning at 1 ml/min and reduce the hold time to 5 min in step 3 of the method described below.*
 - *NaOH should not be left in the flow cell for more than 20 minutes and proper care should be taken to remove the NaOH completely from the flow cell.*

Cleaning the UV flow cell in-place

Follow the instructions below to clean the **UV flow cell**.

Note: *Before cleaning the **UV flow cell**, remove the column from the flow path and re-connect the flow path. See Section 8.3.1 Disconnect the column, on page 212.*

Step	Action
------	--------

- | | |
|---|--|
| 1 | Immerse the inlet tubing in cleaning solution. |
|---|--|

Step	Action
2	Start a manual run and pump cleaning solution at 5 ml/min through the UV flow cell for 10 minutes and pause the run.
3	Leave the UV flow cell filled with cleaning solution for 15 minutes.
4	Immerse the inlet tubing in DM water.
5	Resume the run and rinse the flow cell thoroughly with DM water.

8.5 Cleaning the Conductivity flow cell

Maintenance interval

Clean the **Conductivity flow cell** when the **Conductivity** Monitor shows a slow response or when the conductivity measurements are not comparable to previous results.

Required solutions

The following solutions are required:

- 1 M NaOH
 - DM water
-

Cleaning the Conductivity flow cell in-place

Follow the instructions below to clean the **Conductivity flow cell**.

Note: *Before cleaning the **Conductivity flow cell**, remove the column from the flow path and re-connect the flow path. See Section 8.3.1 Disconnect the column, on page 212.*

Step	Action
1	Immerse the inlet tubing (either A or B) in 1 M NaOH.
2	Start a manual run and pump 1 M NaOH at 1 ml/min through the flow cell for 10 minutes.
3	Pause the run. Leave the Conductivity flow cell filled with 1 M NaOH for 15 minutes.
4	Immerse the inlet tubing in DM water.
5	Resume the run and rinse the flow cell thoroughly.

Note:

- *Do not leave NaOH in the flow cell for more than 20 min to avoid damage. Rinse the flow path with water thoroughly.*
 - *Make sure that the NaOH is completely removed. The conductivity reading in the **Run view** screen should be < 1 mS/cm.*
-

8.6 Cleaning the valves

Introduction

Valve cleaning is required to avoid any cross-contamination or salt crystal formation. Salt deposits may form if the flow path is not flushed out to remove buffer solutions after performing a run.

It is recommended to clean the valves (at least with DM water).

- after every run, or
- at the end of the day, or
- while leaving the instrument idle for several days.

The following protocols describe the ways of cleaning the valves:

- Cleaning the **Buffer valve** and **Wash valve**
 - Cleaning the **Sample valve** using ÄKTA start stand-alone
 - Cleaning the **Sample valve** using UNICORN start
-

Cleaning the Buffer valve and Wash valve

The Buffer valve and Wash valve can be cleaned using DM water.

Note: *If more thorough cleaning is required, 1 M NaOH may be used. When NaOH is used for cleaning, make sure to wash the flow path thoroughly with DM water before starting a run.*

Follow the instructions provided in ÄKTA start Maintenance Cue Card (29024043), Section *Cleaning system flow path*:

- Perform **Pump wash B** and **Pump wash A** for cleaning the buffer valve and wash valve (Pump wash flow rate is 10 ml/min).
 - If using NaOH for cleaning, repeat the **Pump wash B** and **Pump wash A** protocols with DM water until the NaOH is completely removed.
-

Cleaning the Sample valve using ÄKTA start stand-alone

The **Sample valve** can be cleaned using DM water.

Note: *If a more thorough cleaning is required, 1 M NaOH may be used. When NaOH is used for cleaning, make sure the flow path is thoroughly washed with DM water before starting a run.*

8 Maintenance

8.6 Cleaning the valves

Follow the instructions below to clean the **Sample valve** using ÄKTA start stand-alone instrument.

Step	Action
------	--------

1	Immerse the sample inlet tubing in the cleaning solution (DM water or 1 M NaOH).
---	--

2	In the ÄKTA start home screen, tap Manual run .
---	--

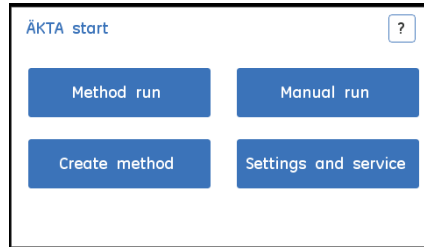

3	<ul style="list-style-type: none">In the Manual run screen (1/2), set the Flow rate to 5 ml/min.Clear Save Result to USB.Tap the forward arrow to go to Manual run screen 2/2.
---	--

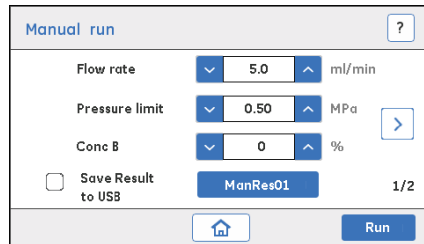

4	<ul style="list-style-type: none">Set Sample valve to Sample.Set Wash valve to Column.Set Outlet valve to Waste.Tap Run to start the run.
---	---

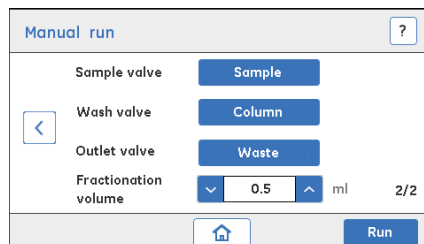

Step	Action
5	After 3 to 5 minutes, tap End to end the run.

Cleaning the Sample valve using UNICORN start

Follow the instructions below to clean the **Sample valve** using UNICORN start.

Step	Action
1	Immerse the sample inlet tubing into the cleaning solution (DM water or 1 M NaOH).
2	Start the computer and launch UNICORN start and connect to ÄKTA start.
3	In the UNICORN start System Control module, click Manual run .
4	In the Manual Run settings dialog, set the Flow Rate to 5 ml/min and click OK .



5	In the process picture, set Sample valve to Sample and Wash valve to Column position (see green highlighted flow path in the process picture).
---	--

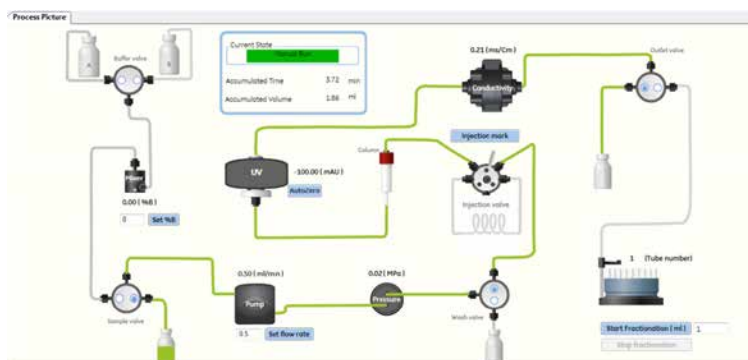

6	After 3 to 5 minutes, end the run.
---	------------------------------------

8.7 Other cleaning procedures

Introduction

This section provides instructions for additional cleaning procedures to be performed by the user of ÄKTA start.

In this section

This section contains the following subsections:

Section	See page
8.7.1 Cleaning the inlet filters	223
8.7.2 Cleaning the instrument externally	224
8.7.3 Cleaning the Fraction collector	225

8.7.1 Cleaning the inlet filters

Maintenance interval

Clean the inlet filters when required, for example when the visual inspection shows that the filters are clogged.

Required solutions

The following solutions are required:

- 1 M NaOH
 - DM water
-

Instruction

Follow the instructions below to clean the inlet filters.

Step	Action
1	Pull off the support net and the inlet filter from the inlet filter holder. See <i>Section 8.9.1 Replace the inlet filters, on page 231</i> .
2	Immerse and leave the inlet filter and the support net in 1 M NaOH for about 2 hours. Alternatively use a shorter time in an ultrasonic bath.
3	Remove the inlet filter and the support net from the NaOH solution and rinse thoroughly with DM water.
4	Fit the inlet filter into the support net, and press it into position on the inlet filter holder.

8.7.2 Cleaning the instrument externally

Maintenance interval

Clean the instrument externally when required. Do not allow spilled liquid to dry on the instrument.

Required material

The following materials are required:

- Cleaning cloth
 - Mild cleaning agent or 20% ethanol
-

Instruction

Follow the instructions below to clean the instrument externally.

Step	Action
1	Check that no run is in progress.
2	Switch off the instrument.
3	Wipe the surface with a damp cloth. Wipe off stains using a mild cleaning agent or 20% ethanol.
4	Let the instrument dry completely before using it.

8.7.3 Cleaning the Fraction collector

Maintenance interval

Clean the fraction collector when required, for example in case of liquid spill in the Bowl assembly.

Required material

The following materials are required for cleaning the Bowl assembly:

- Water
 - 20% ethanol
 - Cleaning cloth
-

Instruction

Follow the instructions below to disassemble and clean the Bowl assembly.

Step	Action
1	Check that no run is in progress.
2	Switch off ÄKTA start and disconnect the Frac30 Cable.
3	Remove the collection tubes and disassemble the Bowl assembly from the Base unit: <ul style="list-style-type: none">• Gently move the Dispenser arm counterclockwise to the end position (1)• Push the drive assembly and hold it at the retracted position (2)• Lift and remove the Bowl assembly (3)

Step	Action
------	--------



- 4 Wash the Bowl under a water tap. Use a mild detergent if required, and rinse thoroughly with water.
- 5 Wipe the surface with a damp cloth. Wipe off stains using water.
- 6 Let the Bowl assembly dry completely before re-assembling.
- 7 Re-assemble the Bowl assembly on to the Base unit:
 - Orient the Bowl to match the aligning groove and the aligning features on the Bowl holder (1)
 - Lower the bowl assembly on to the Base unit (2) and push the drive assembly to allow the Bowl assembly to get in position (3)

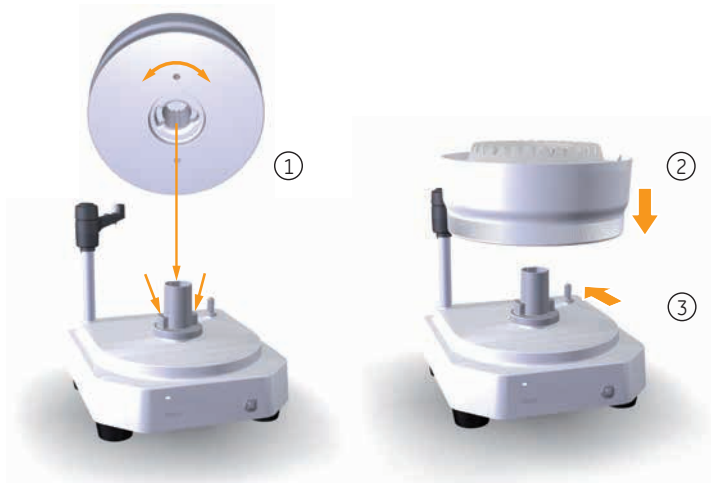

Removing the tube holder

Note: Do not remove the tube holder from the bowl except when cleaning is necessary. Frequent removal may damage the snap locks.

Follow the instructions below to remove and refit the tube holder in the Bowl assembly.

Step	Action
------	--------

- | | |
|---|---|
| 1 | To remove the tube holder, unsnap the snap locks one by one and sequentially for ease of removal. |
|---|---|

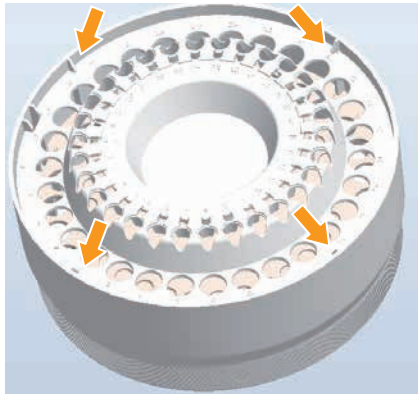

- | | |
|---|--|
| 2 | To refit the tube holder in the Bowl assembly: |
|---|--|

- Align the holder with the help of the aligning groove.

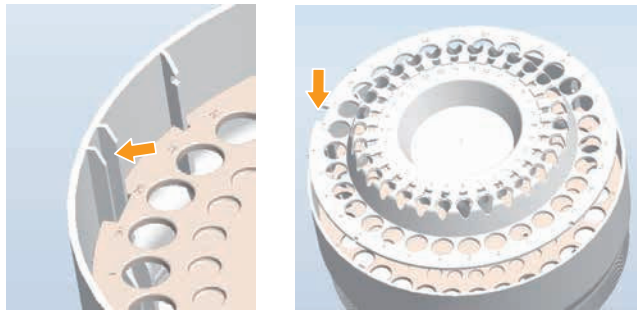

- Snap fit the part by operating one snap at a time in a continuous sequence by pressing on the edge of the tube holder.

8.8 Storage of the instrument

Required material

The following materials are required:

- DM water
 - 20% ethanol
 - 0.75 mm i.d. PEEK tubing
 - Waste container
-

Short term storage

If the system is not going to be used for a few days, follow the instructions below to prepare the system for short term storage.

Note: *Before cleaning the flow path, remove the column and re-connect the flow path. See Section 8.3.1 Disconnect the column, on page 212.*

Step	Action
------	--------

- | | |
|---|---|
| 1 | Immerse the buffer and the sample inlet tubing in DM water. |
| 2 | In the ÄKTA start home screen, tap Manual run . For detailed instructions, see Section 6.3 Perform a manual run, on page 149.
Set the run parameters according to the table below. |

Parameter	Setting
<i>Flow rate</i>	1 ml/min
<i>Pressure limit</i>	0.5 MPa
<i>Select Buffer/Sample</i>	Buffer
<i>Wash valve</i>	Column
<i>Outlet valve</i>	Waste

- | | |
|---|---|
| 3 | Tap Run to start the manual run.
Pump 20 ml of DM water through the system. |
|---|---|

Step	Action						
4	<p>Tap Edit run and set the run parameters as indicated below.</p> <p><i>Result:</i> The sample inlet tubing and the outlet tubing for fraction collection will be flushed with DM water.</p> <table border="1"> <thead> <tr> <th>Parameter</th> <th>Setting</th> </tr> </thead> <tbody> <tr> <td>Select Buffer/Sample</td> <td>Sample</td> </tr> <tr> <td>Outlet valve</td> <td>Collection</td> </tr> </tbody> </table>	Parameter	Setting	Select Buffer/Sample	Sample	Outlet valve	Collection
Parameter	Setting						
Select Buffer/Sample	Sample						
Outlet valve	Collection						
5	Pump 20 ml of DM water through the system.						
6	End the run and leave the system filled with DM water during the storage period.						

Long term storage

If the system is not going to be used for more than 4 days, follow the instructions below to prepare the system for long term storage.

Note: *Before cleaning the flow path, remove the column and re-connect the flow path. See Section 8.3.1 Disconnect the column, on page 212.*

Step	Action
1	Immerse the buffer and the sample inlet tubing in 20% ethanol.
2	Start a manual run and pump 20 ml of 20% ethanol through the system. Use the same run parameters recommended for the short term storage procedure.
3	Edit the run and set the run parameters to clean the sample inlet tubing and the outlet tubing for fraction collection.
4	Pump 20 ml of 20% ethanol through the system.
5	End the run and leave the system filled with 20% ethanol during the storage period.

8.9 Replacement of tubing and filters

Introduction

This section describes how to replace tubing and connectors, and how to replace the inlet filters.



CAUTION

Make sure that the entire system tubing is flushed with demineralized water, before starting the replacement of tubing.

In this section

This section contains the following subsections:

Section	See page
8.9.1 Replace the inlet filters	231
8.9.2 Replace the tubing and connectors	232

8.9.1 Replace the inlet filters

Maintenance interval

Replace the inlet filters when required, for example when the visual inspection shows that the filters are clogged or damaged and cleaning is not sufficient.

Required items

The following items are required:

- inlet filters
- support nets

Note: *An Inlet Filter Set containing inlet filters and support nets is included in the accessories kit.*

Instruction

Follow the instruction below to replace an inlet filter and a support net.

Note: *The inlet filters are mounted on the inlet tubing at the end that will be immersed in the buffer solution.*

Step	Action
1	Pull off the inlet filter and the support net from the inlet filter holder.

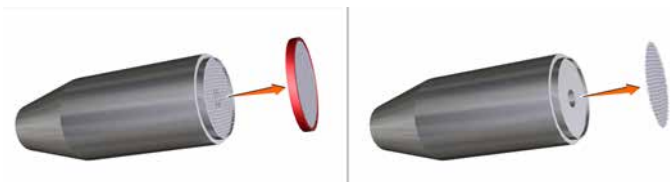

2	Fit the new support net and inlet filter, and press the filter in position into the inlet filter holder.
---	--

8 Maintenance

8.9 Replacement of tubing and filters

8.9.2 Replace the tubing and connectors

8.9.2 Replace the tubing and connectors

Maintenance interval

Replace tubing and connectors when required, for example when the tubing is clogged or bent and the flow is obstructed.

Note: *Before starting to replace tubing and connectors, clean the system flow path with DM water, then remove the inlet tubing from water.*

Required items

The following items are required:

- Tubing and connectors
 - Tubing cutter (included in the ÄKTA start accessory kit)
-

Instruction

Follow the instructions below to replace tubing and connectors.

Note: *To replace the pump tubing (Marprene™ tubing, Part No. 29024012), follow the instruction in the ÄKTA start Maintenance Manual.*

Note: *To replace the tubing that connects the **UV** monitor to the **Conductivity** monitor use the pre-bent tubing supplied with the system.*

Step	Action
------	--------

- | | |
|---|---|
| 1 | Unscrew the connectors, and disconnect the tubing. |
| 2 | If the tubing has labels, remove the labels and use them with the new tubing later. Discard the used tubing and connectors. |

Step	Action
3	Cut the new tubing to the same length as the original tubing. Use a tubing cutter to get a correct right-angle cut.

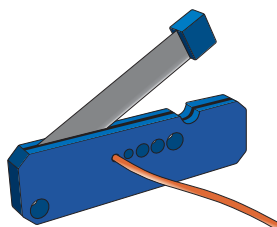

CAUTION

Cut injuries. The tubing cutter is very sharp and must be handled with care to avoid injuries.

Note:

When replacing system tubing, use the original inner diameter and length to ensure that the correct delay volumes are maintained. Inlet and outlet tubing may be shortened if required.

5	Put the labels back on the new tubing.
6	Mount the connectors on the tubing. For fingertight connectors: <ul style="list-style-type: none">• Slide the connector onto the tubing. For tubing connectors 1/8": <ul style="list-style-type: none">• Slide the connector onto the tubing.• Slide the ferrule onto the tubing with the thick end towards the end of the tubing.
7	Insert the tubing with connector into the port. Make sure to insert the tubing all the way into the bottom of the port.
8	Tighten the connector fully.

9 Troubleshooting

About this chapter

This chapter describes basic troubleshooting and corrective actions for ÄKTA start. A complete list of error and warning messages is provided in the *ÄKTA start Maintenance Manual*.

In this chapter

This chapter contains the following sections:

Section	See page
9.1 Introduction to troubleshooting	235
9.2 Basic troubleshooting	237
9.3 System error report	249

9.1 Introduction to troubleshooting

Introduction

The sections in this chapter describe the basic troubleshooting for ÄKTA start and include a general checklist that should be completed prior to the troubleshooting work. How to generate a System error report for service purposes is also described. For replacement of modules and other module specific problems and corrective actions, refer to the *ÄKTA start Maintenance Manual*.

Refer to the *UNICORN start User Manual* for problems related to the software.

Troubleshooting procedure

To troubleshoot ÄKTA start, follow these steps:

Step	Action
1	Follow the checklists below, for system, flow path, and purification.
2	If problems remain, search for solutions in <i>Section 9.2 Basic troubleshooting, on page 237</i> .
3	If problems remain after corrective actions, generate a System error report (<i>Section 9.3 System error report, on page 249</i>) and contact your local GE Service Engineer.

System checks

- Does the instrument display show the **ÄKTA start** home screen?

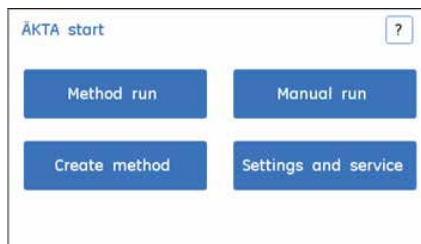

- Does the ventilation of the instrument function? The fans should be audible at all times when the instrument is switched on. Contact a GE Service Engineer if the fans at the bottom of the instrument stop running.
-

Flow path checks

- Is all tubing connected correctly, as shown in *Section 5.1 Flow path overview, on page 89*?
 - Is there leakage at any of the connections? Tighten the connections if required.
 - Is any tubing bent or twisted? Adjust the tubing position to make sure that the flow of liquid is smooth, or replace the tubing if required.
 - Is the buffer inlet tubing immersed in correct buffer solutions? See *Section 5.10 Starting a run, on page 140*.
 - Are the inlet filters clean? Clean or replace the filters if required. See *Section 8.7.1 Cleaning the inlet filters, on page 223*, and *Section 8.9.1 Replace the inlet filters, on page 231*.
 - Is the column connected correctly? See *Section 5.5 Connect a column, on page 109*.
-

Purification checks

- Has the column been cleaned and prepared according to the recommendations in the column instruction manual?
 - Has the sample been adjusted to binding buffer conditions?
 - Has the sample been clarified by centrifugation and/or filtration prior to the sample loading?
 - Are the correct buffers used for the chosen columns and proteins?
 - Check buffers for precipitations and contamination. Adjust the required temperature wherever needed.
 - Are the chosen columns suitable for the chosen target proteins?
 - Have the stable baselines for **UV** and **Conductivity** been established?
-

9.2 Basic troubleshooting

Introduction

This section describes problems that can occur with the Display, UV and Conductivity measurements, problems with the wet side modules, possible causes, and the recommended corrective actions. If error codes are displayed on the Instrument Display, refer to *ÄKTA start Maintenance Manual*.

Display

Description	Possible cause	Action
The Instrument display does not show anything	No power.	Check that the Power cord is connected and that the Power Switch is switched on.
	The Instrument display is damaged.	Contact a GE Service Engineer.
	Communication problem, no signals to the display.	Contact a GE Service Engineer.
Issues with the touch response	Calibration may be misaligned.	Re-calibrate the Instrument Display. For details, refer to the <i>ÄKTA start Maintenance Manual</i> .
The Display color is not correct	Display malfunction. Display interface cable is loose.	Perform a Display:Color test (see the <i>ÄKTA start Maintenance Manual</i>). If there is a pattern mismatch, contact a GE Service Engineer.
The Display Backlight is not working	Display malfunction. Display interface cable is loose.	Perform Display:Diagnostics and adjust the backlight setting if necessary (see the <i>ÄKTA start Maintenance Manual</i>). If adjustment does not affect the backlight intensity, contact a GE Service Engineer.

UV curve

Description	Possible cause	Action
Noisy UV signal, signal drift or instability	If UV noise level is above 10 mAU, air bubbles may be trapped in the flow cell.	Remove the air bubbles trapped in the UV flow cell by flushing the cell with DM water or buffer. If persistent, clean the UV flow cell . See <i>Section 8.4 Cleaning the UV flow cell</i> , on page 216.
	Buffer is impure.	Check if the signal is still noisy with DM water.
	Air dissolved in the buffer or air bubbles seen in the buffer inlet tubings.	Degas the buffer before use. Use a technique available in the laboratory, such as vacuum degassing or sonication. Perform Pump wash to remove the air bubbles from the flow path.
	UV flow cell not clean.	Clean the UV flow cell . See <i>Section 8.4 Cleaning the UV flow cell</i> , on page 216.
	UV flow cell not mounted properly, locknut not tightened.	Remove the protective cover and check the flow cell. Tighten the locknut.
Ghost peaks	Air dissolved in the buffer.	Degas the buffer before use. Use a technique available in the laboratory, such as vacuum degassing or sonication.
	Flow path not clean.	Clean the system flow path. See <i>Section 8.3 Cleaning the system flow path</i> , on page 210.
	Column not clean.	Clean the column according to the column instructions.
Low sensitivity	UV flow cell not clean	Clean the UV flow cell . See <i>Section 8.4 Cleaning the UV flow cell</i> , on page 216.
Waves on the gradient	Switch valve timing not optimized.	Adjust the Switch valve timing . See <i>Section 5.4.4 Switch valve timing</i> , on page 105.

Description	Possible cause	Action
<p>Warning 111: UV intensity low</p>	<ul style="list-style-type: none"> • UV Module is not calibrated properly. • Flow cell is not clean. • Flow cell is not mounted properly. • UV LED intensity is below desired level. 	<p>Mount flow cell securely and re-calibrate the UV module with the flow cell filled with DM water. If the problem persists, replace the UV module. For details, refer to the <i>ÄKTA start Maintenance Manual</i>.</p>
<p>Warning 112: UV intensity high</p>	<ul style="list-style-type: none"> • Calibration was not performed on a clean flow cell. • Flow cell is not mounted properly. 	<p>Mount the flow cell securely, clean and re-calibrate UV module with the flow cell filled with DM water. For details, refer to the <i>ÄKTA start Maintenance Manual</i>.</p>
<p>Warning 115: Flush flow cell and mount securely</p>	<p>Flow cell not mounted properly or is optically misaligned</p>	<p>Flush the flow cell. Mount the flow cell properly. Re-calibrate the UV module with flow cell filled with DM water.</p>
<p>Warning 116: UV base lining ignored</p>	<p>Flow cell is not clean.</p>	<p>Clean the flow cell thoroughly with DM water. Re-calibrate the UV module with the flow cell filled with DM water.</p>

Conductivity curve

Description	Possible cause	Action
Incorrect or unstable reading or Out of specification conductivity values	Conductivity cell not clean.	Clean the Conductivity cell. See <i>Section 8.5 Cleaning the Conductivity flow cell, on page 218.</i>
	Cable improperly connected to the Conductivity Monitor.	Check that the Conductivity module cable is connected properly to the connector behind the flow cell.
	Pump malfunction.	Check that the Pump functions properly. See Pump troubleshooting.
	Temperature sensor not calibrated.	Calibrate the temperature sensor. See <i>Section 5.3 Calibration guidelines, on page 93.</i>
	Non-equilibrated column.	Check that the column is equilibrated. If necessary, clean the column.
	Buffer valve malfunction.	Check the operation of the Buffer valve . Refer to the <i>ÄKTA start Maintenance Manual.</i>
	The 0.5 mm ID (195 mm) PEEK tubing is not connected between the Conductivity Monitor and the Outlet valve .	Connect 0.5 mm ID PEEK tubing. See <i>Section 8.9.2 Replace the tubing and connectors, on page 232.</i>
Baseline drift or noisy signal	Failure of component in Main board	Contact a GE Service Engineer.
	Air trapped in the conductivity flow cell.	Remove the air trapped in the flow cell by flushing the cell with DM water or buffer. If persistent, clean the Conductivity flow cell . See <i>Section 8.5 Cleaning the Conductivity flow cell, on page 218.</i>
	Non-equilibrated column.	Check that the column is equilibrated. If necessary, clean the column.
	Pump malfunction.	Check that the pump functions properly. See Pump troubleshooting.

Description	Possible cause	Action
Conductivity measurement with the same buffer changes over time at constant temperature	Flow cell not clean.	Clean the Conductivity flow cell , see <i>Section 8.5 Cleaning the Conductivity flow cell, on page 218.</i>
Waves on the gradient	Pump or Buffer valve malfunction.	Check that the Pump and the Buffer valve operate properly. Refer to <i>ÅKTA start Maintenance Manual.</i>
	Switch valve timing not optimized.	Adjust Switch valve timing . See <i>Section 5.4.4 Switch valve timing, on page 105.</i>
	Wrong absolute conductivity value.	Conductivity flow cell not calibrated Recalibrate the Conductivity flow cell . See <i>Section 5.3 Calibration guidelines, on page 93.</i>
Temperature sensor not calibrated		Calibrate the temperature sensor. See <i>Section 5.3 Calibration guidelines, on page 93.</i>
Calibration solution (1.00 M NaCl) not correctly prepared		Prepare a new calibration solution and recalibrate the Conductivity flow cell .
Ghost peaks in the gradient profile	A charged sample was detected (e.g., a protein).	Clean the Conductivity flow cell , see <i>Section 8.5 Cleaning the Conductivity flow cell, on page 218.</i>
	Air bubbles pass through the flow cell.	Check for loose tubing connections.

Description	Possible cause	Action
Non-linear gradients or slow response to %B changes	Buffer valve malfunction.	See Buffer valve troubleshooting.
	Irregular flow.	Check that the Pump functions properly. See Pump troubleshooting.
	Tubing not clean.	Make sure that the tubing is washed properly. Run System cleaning to clean the system flow path. See <i>Section 8.3 Cleaning the system flow path, on page 210</i> .

Pump

Description	Possible cause	Action
Erratic flow	Air bubbles in the flow path.	<p>Remove the air bubbles trapped in the flow path by flushing the flow path with DM water or buffer according to the procedure below:</p> <ul style="list-style-type: none"> remove the column and re-connect the flow path (see <i>Section 8.3.1 Disconnect the column, on page 212</i>) perform a manual run with a flow rate of 5 ml/min for about 10 minutes observe the graph until the pulsations are no longer visible and the curve is stable <p>Note: <i>If there is air trapped in the flow path, the flow is not accurate and pulsations can occur, affecting the output signals.</i></p>
	Worn out pump tubing.	Replace the pump tubing. See <i>Section 8.9.2 Replace the tubing and connectors, on page 232</i> .

Description	Possible cause	Action
Inaccurate flow rate (detected by incorrect fraction sizes)	Pump not calibrated.	Calibrate the Pump . See <i>Section 5.3 Calibration guidelines, on page 93</i> .
	Pump tubing not properly positioned.	Place the pump tubing in the pump hood maintaining equal distance on both the sides.
	Worn out pump tubing.	Replace the pump tubing. See <i>Section 8.9.2 Replace the tubing and connectors, on page 232</i> .
No flow	Pump tubing is not fixed inside the pump hood.	Fix the pump tubing inside the pump hood and start the run.
	Failure of component in Main board.	Troubleshoot the Pump and if the problem still persists, contact a GE Service Engineer.
Leakage	Tubing connection.	Check the tubing connections. Re-tighten or replace if necessary.

Mixer

Description	Possible cause	Action
Leakage	Tubing connection.	Check the tubing connections. Re-tighten or replace if necessary.

Fraction collector

Description	Possible cause	Action
The fractions collected fall outside the collection tubes.	Bowl Assembly improperly fitted on the Base unit.	Make sure that the Bowl is fitted properly on the base.
	Dispenser arm not in correct position.	Check that the dispenser arm is in the dispensing position. Notice the alignment of the markings on the dispenser arm.
	Drive sleeve is worn out and slip-page occurs.	Replace the drive sleeve. Refer to the <i>ÄKTA start Maintenance Manual</i>
Fraction collector is not set to the home position at the start of the run.	Fraction collector is not connected to the instrument.	Connect the Fraction collector to ÄKTA start
	Fraction collector option is not enabled.	Enable the Fraction collector option from the Settings and service screen.

Buffer/Sample/Wash/Outlet valves

Description	Possible cause	Action
Leakage from the valve ports or connections	Tubing connections	Check the tubing connections. Tighten or replace if required.
Leakage from the valve body	Internal parts may be worn	Replace valve. Refer to <i>ÄKTA start Maintenance Manual</i> .
	Salt crystal formation	Clean the system flow path and valves. See <i>Section 8.3 Cleaning the system flow path, on page 210</i> and <i>Section 8.6 Cleaning the valves, on page 219</i> .
High back-pressure	Flow path not clean	Clean the system flow path. See <i>Section 8.3 Cleaning the system flow path, on page 210</i> .

Description	Possible cause	Action
Valve not switching position	Internal parts may be worn	Replace valve. Refer to <i>ÄKTA start Maintenance Manual</i> . If the valve does not function even after replacement, contact a GE Service Engineer.

Injection valve

Description	Possible cause	Action
The valve switches to wrong position	Valve parts incorrectly assembled after replacement	Make sure that the marking etched on the valve aligns correctly with the same marking on the instrument. Refer to <i>ÄKTA start Maintenance Manual</i> .
External leakage	Tubing connections	Check the tubing connections. Tighten or replace if required.
Internal leakage	Internal parts may be worn	Replace valve. Refer to <i>ÄKTA start Maintenance Manual</i> .
High back-pressure	Flow path not clean	Clean the system flow path. See <i>Section 8.3 Cleaning the system flow path, on page 210</i> .
Unable to load sample to the loop	Manual injection valve is in the In-ject position.	Turn the Injection valve to Load position while loading the sample to the loop.
	The Valve or the loop is blocked	Clean the system flow path. If problem persists, replace the valve/loop.

Pressure sensor

Description	Possible cause	Action
Error 501: Over pressure	<ul style="list-style-type: none"> Blockage in tubing, valves or in the column. Improperly selected flow rate. 	<ul style="list-style-type: none"> Check the tubing and valves by disconnecting one at a time. Clean or replace when a blockage is found. Clean the column/separation media with suitable solution (1 M NaOH) or replace the column with a new one. Check the specification of the columns for correct flow rate.
Pressure sensor is not functioning. Pressure curve is not displayed on the screen.	Pressure sensor failure or failure of component in Main board.	Contact a GE Service Engineer.

User Information Messages

Description	Possible cause
Instruction ignored message: <i>Instruction ignored, not allowed to set the inlets during gradient.</i>	This message is shown when it is not possible to give the instruction during <i>Gradient.</i>
Occurrence message: <i>The instruction Outlet valve is not possible to issue during an active fractionation.</i>	This message appears after the delay volume has passed while fractionation is active.
Occurrence message: <i>Instruction ignored. Stop fractionation is only allowed during fractionation.</i>	This message appears when the instruction <i>Stop fractionation</i> is issued but fractionation is not active.
Warning message: <i>Instruction ignored. Peak fractionation is not allowed during fractionation or Single peak collection.</i>	This warning message appears when an instruction is not possible to execute during <i>Single peak collection</i> or during <i>Fractionation.</i>

Description	Possible cause
Warning message: <i>Last tube has been reached; change tubes in the fraction collector and press Continue to continue the run with fractionation. Press Cancel fractionation to continue the run without fractionation flow is diverted to Flow through/Waste position.</i>	This message appears when the last tube has been reached.
Occurrence message: <i>Last tube has been reached and the run has continued without fractionation.</i>	This message appears if <i>Continue without fractionation</i> is selected.
Warning message: <i>Instruction ignored. Single peak collection is not allowed during 'Fractionation' or 'Peak fractionation'!</i>	This message appears when one tries to execute <i>Single peak collection</i> during fractionation.
Warning message: <i>Turning Outlet valve is not allowed during Single peak fractionating.</i>	This message is displayed to show that the <i>Outlet valve</i> will not turn during <i>Single peak fractionation</i> .
Occurrence message: <i>Instruction ignored. Stop single peak collection is only allowed during single peak collection.</i>	This message is displayed when the instruction <i>Single peak collection</i> has not been executed.
<i>USB removed abruptly.</i>	This message appears when the user removes the USB memory stick while read or write operation is being executed.

USB memory stick connection

To troubleshoot possible issues encountered when connecting a USB memory stick to ÄKTA start, follow the procedure presented in the flow chart below.

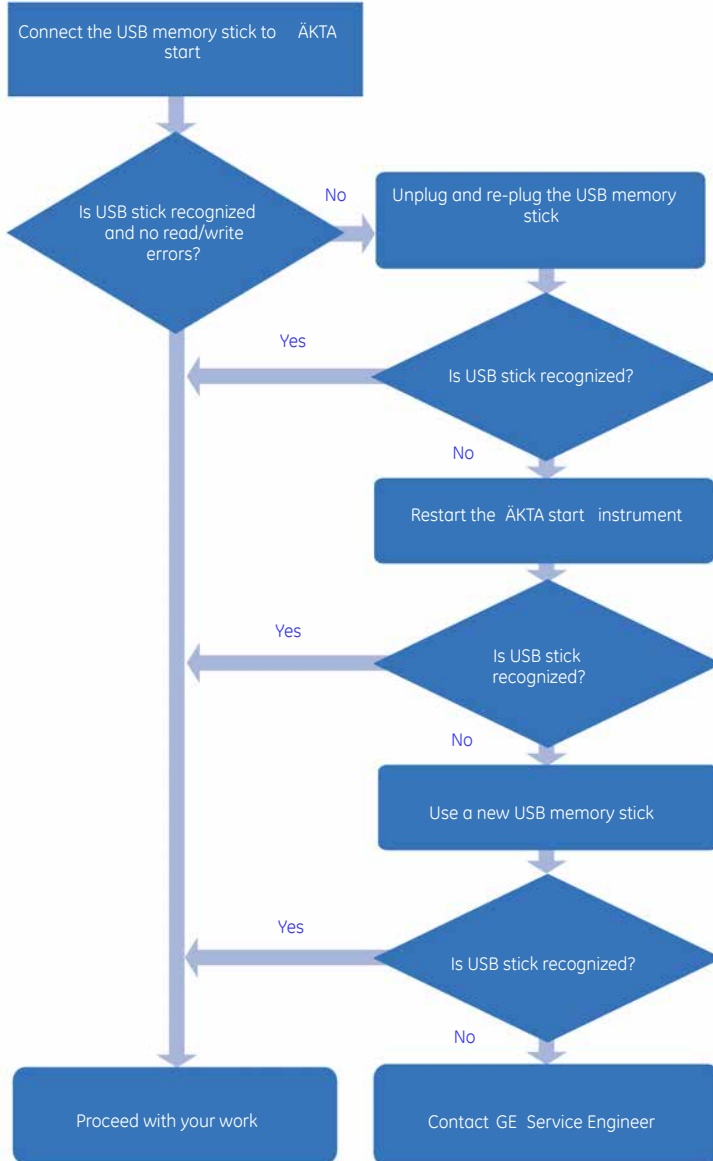

9.3 System error report

Introduction

A System error report can be generated during a troubleshooting case with information about the problem. The report can then be sent to GE Service Engineer for action.

Generate a System error report

Follow the instructions below to generate a System error report.

Note: Make sure that a USB memory stick is connected to the instrument. If the instrument cannot detect a USB memory stick, the report file cannot be saved.

Step	Action
------	--------

- | | |
|---|---|
| 1 | In the ÄKTA start home screen, tap Settings and service to access Screen 1 (see Section 3.3.4 Description of Settings and service, on page 57), and then select System . |
|---|---|

Settings and service Screen 1



- | | |
|---|---|
| 2 | Insert a USB memory stick into the USB port located on ÄKTA start. In the System screen, select Export system error report to USB . |
|---|---|



Result: Two files with the names INSTLOG.TXT and ERRORLOG.TXT are exported to the USB memory stick.

Step Action

- 3 Remove the USB stick from the USB port and connect it to a computer. Check the content of the system report files INSTLOG.TXT and ERRORLOG.TXT. The content should look similar to the images below.

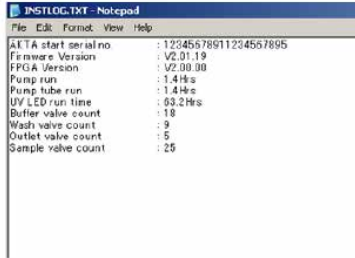

- 4 Use the system report in further contacts with GE Service Engineer.

10 Reference information

About this chapter

This chapter lists the technical specifications of ÄKTA start. The chapter also includes a list of wetted materials, a chemical resistance guide, Health and Declaration form for service, and ordering information.

In this chapter

This chapter contains the following sections:

Section	See page
10.1 Specifications	252
10.2 Chemical resistance	258
10.3 Literature	261
10.4 Health and Safety Declaration Form	262
10.5 Ordering information	264

10.1 Specifications

Introduction

This section lists the specifications of ÄKTA start. For component specifications see the *ÄKTA start Maintenance Manual*.

System specifications

Parameter	Data
System configuration	Benchtop system
Control system	Instrument Display and/or UNICORN start
Connection between PC and instrument	USB
Dimensions (W × D × H)	340 mm × 280 mm × 360 mm
Weight (excluding packaging)	8 kg
Power supply	100 to 240 V AC ± 10%, 50/60 Hz
Power consumption	95 VA
Transient overvoltages	Overvoltage category II
Fuse	Fast blow glass tube type, F5AL250V
Enclosure protective class	IP21
Tubing and connectors:	
Inlet	PTFE tubing, length 100 cm, i.d. 1.6 mm, 5/16-24 UNF connections
Buffer valve to Mixer	PEEK tubing, Length 15 cm, i.d. 0.75 mm, 10-32 UNF connections
Mixer to Sample valve	PEEK tubing, Length 23 cm, i.d. 0.75 mm, 10-32 UNF connections
Sample valve to Pressure sensor (via Pump)	Marprene tubing, Length 25 cm, i.d. 0.8 mm, 10-32 UNF connections
Pressure sensor to Wash valve	PEEK tubing, Length 13 cm, i.d. 0.75 mm, 10-32 UNF connections

Parameter	Data
Wash valve to Injection valve	PEEK tubing, Length 17 cm, i.d. 0.75 mm, 10-32 UNF connections
Injection valve to Column	PEEK tubing, Length 15 cm, i.d. 0.75 mm, 10-32 UNF connections
Column to UV	PEEK tubing, Length 15 cm, i.d. 0.75 mm, 10-32 UNF connections
UV to Conductivity	PEEK tubing, Length 20 cm, i.d. 0.75 mm, 10-32 UNF connections
Conductivity to Outlet valve	PEEK tubing, Length 19 cm, i.d. 0.50 mm, 10-32 UNF connections
Outlet valve to Frac30	PEEK tubing, Length 50 cm, i.d. 0.75 mm, 10-32 UNF connections
Waste tubing	ETFE tubing, Length 60 cm i.d. 1.0 mm, Fingertight connector, 1/16"
Sample tubing	ETFE tubing, Length 25 cm, i.d. 1.0 mm, Fingertight connector, 1/16"

Equipment noise level

Parameter	Value
Noise emission	< 60 dB(A)

Environmental ranges

Parameter	Data
Operation site	Indoor use
Altitude	Maximum 2000 m
Storage and transport temperature range	-10°C to 60°C
Humidity	20% to 80%, non-condensing
Pollution degree	2

10 Reference information

10.1 Specifications

Operating range

Parameter	Data
Operating temperature range	+4°C to 35°C
Relative humidity	20% to 80%, non-condensing

Pump

Parameter	Data
Pump type	Peristaltic Pump. Single channel, four roller pump head with low pulsation
Flow rate	0.5 to 5 ml/min (operating range) 10 ml/min (Wash flow)
Flow rate specifications	<ul style="list-style-type: none">• Accuracy:<ul style="list-style-type: none">- Flow rate \leq 1 ml/min: \pm 15%- Flow rate $>$ 1 ml/min: \pm 10%• Precision:<ul style="list-style-type: none">- Flow rate \leq 1 ml/min: \pm 15%- Flow rate $>$ 1 ml/min: \pm 10% Conditions: Viscosity 0.8 to 2 cP, fresh Pump tubing.
Pressure range	0 to 0.5 MPa (0 to 5 Bar)
Viscosity range	0.6 to 5 cP

Mixer

Parameter	Data
Mixing principle	Static mixer
Mixer volume	0.4 ml

Valves: Buffer, Sample, Wash and Outlet

Parameter	Data
Type	Solenoid type switch valve
No. of Ports	3 ports: <ul style="list-style-type: none"> • Buffer valve and Sample valve: 2 in – 1 out • Wash valve and Outlet valve: 1 in – 2 out

Injection valve

Parameter	Data
Type	Rotary type manual valve
Function	Sample injection through Loop .
No. of Ports	6 ports

Gradient formation

Parameter	Data
Gradient flow rate range	0.5 to 5 ml/min
Gradient composition accuracy	± 5% Conditions: 5% to 95% B, 1 to 5 ml/min, 0.8 to 2 cP and fresh pump tubing.

Pressure sensor

Parameter	Data
Placement of sensor	Pressure sensor is located after the Pump .
Range	0 to 0.5 MPa (0 to 5 Bar)
Accuracy	± 0.05 MPa

10 Reference information

10.1 Specifications

UV

Parameter	Data
Wavelength	280 nm \pm 3 nm, single wavelength
Absorbance range	-0.1 to 2 AU
Linearity	Within \pm 5% up to 1.5 AU
Operating pressure	0 to 0.5 MPa (0 to 5 Bar)
Flow cell optical path length	2 mm
Flow cell total volume	30 μ l

Conductivity

Parameter	Data
Conductivity range	0 to 300 mS/cm
Resolution	1 mS/cm
Accuracy	\pm 5% or \pm 2 mS/cm (whichever is greater)
Operating pressure	0 to 0.5 MPa (0 to 5 Bar)
Flow cell Volume	22 μ l
Temperature monitor range	4°C to 35°C
Temperature monitor accuracy	\pm 10% or \pm 5°C (whichever is greater)

Frac30

Parameter	Data
Number of fractions	Up to 30

Parameter	Data
Vessel type	<ul style="list-style-type: none"> Centrifuge tubes (10 to 12 ml) Falcon tubes (15 ml) Eppendorf tubes (1.5 ml or 2 ml) 5 ml tubes (12 × 75 mm)
Fraction volumes	0.5 to 15 ml
Flammable liquids	No
Delay Volume (UV to Dispenser head)	0.49 ml (default)
Dimensions (W × D × H)	270 × 280 × 285 mm
Weight	5 kg

Run parameter specifications

Parameter	Range	Increment
Flow rate	0.5 to 5.0 ml/min	0.1 ml/min
Column volume (CV)	1 to 1000 ml	1 ml
Pressure limit	0.1 to 5.0 bar	0.1 bar
Sample volume	Pump: 0.1 to 1000.0 ml	0.1 ml
	Sample loop: 0.1 to 1000 ml ¹	0.1 ml
	Superloop: 0.1 to 1000 ml ¹	0.1 ml
Wash volume	0.0 to 50.0 CV	0.1 CV
Equilibration volume	0.0 to 50.0 CV	0.1 CV
Elution volume	0.0 to 100 CV	0.1 CV
Target B concentration (%)	0% to 100%	1%
Gradient volume	0.0 to 100.0 CV	0.1 CV
Fractionation volume	0.5 to 15 ml	0.1 ml

¹ This is the permitted range for the input parameter in UNICORN start. The usable range may be limited by the sample loop or Superloop volume.

10.2 Chemical resistance

Flow path

All chemicals and concentrations are for short-term (< 1 day) use only, ambient temperature < 25°C, unless otherwise stated. Long-term use is defined as at least 1 month.

The flow path shall withstand the following suggested chemicals.

Chemical	Concentration	CAS no. /EEC no.	Usage
Aqueous buffers, pH 2 to 12	-	N/A	Separation
Acetone	10%	67-64-1/ 200-662-2	
Acetic acid	6% (1 M)	64-19-7/200-580-7	CIP
Ammonium sulphate	3 M	77-83-20-2/231-984-1	Purification of plasmids
Arginine	2 M	74-79-3/200-811-1	Wash, using protein A gels, Refolding
Benzyl alcohol	4%	100-51-6/202-859-9	Cleaning and storage of columns
Decon 90	10%	1310-58-3/215-181-3	Cleaning
Dimethyl sulfoxide (DMSO)	5%	67-68-5/200-664-3	CIP, RPC, Cell separation
DTT	100 mM	3483-12-3/222-468-7	Reducing agent
DTE	100 mM	6892-68-8/229-998-8	Reducing agent
TCEP (Tris(2-Carboxyethyl)Phosphine)	100 mM	51805-45-9/	Reducing agent
EDTA	100 mM	6381-92-6/205-358-3	Buffer additive
Ethanol	96%	64-17-5/200-578-6	Storage (Long term use)
Ethylene glycol	30%	112-60-7/203-989-9	Buffer additive
Glycerol	30%	56-81-5/200-289-5	Buffer additive
Glycine	0.5 M	56-40-6/200-272-2	Cleaning of MAb binding media

Chemical	Concentration	CAS no. /EEC no.	Usage
Guanidine hydrochloride	6 M	50-01-1/200-002-3	Denaturing of proteins
Hydrochloric acid	0.1 M	7647-01-0/231-595-7	CIP
Imidazole	1 M	288-32-4/206-019-2	Affinity
Isopropanol	70%	67-63-0/200-661-7	CIP
Methanol	100%	67-56-1/200-659-6	RPC, CIP
Mercaptoethanol	20 mM	60-24-2/200-464-6	Reducing agent
Potassium phosphate	1 M	16788-57-1/231-834-5	Buffer
SDS	1%	151-21-3/205-788-1	Detergent
Sodium chloride	4 M	7647-14-5/231-598-3	CIP
Sodium hydroxide, NaOH	1 M	1310-73-2/215-185-5	CIP
Sodium sulphate	1 M	7757-82-6/231-820-9	Buffer
Triton™-X 100	1%	9002-93-1/	Detergent
Tween™ 20	1%	9005-64-5/500-018-3	Detergent
Urea	8 M	57-13-6/200-315-5	Buffer additive, denaturing agent
Water	100%	N/A	(Long term use)

Wet side and external surfaces

Chemical	Concentration	CAS no. /EEC no.
Decon 90	10%	1310-58-3/215-181-3
Ethanol	20%	64-17-5/200-578-6
Hydrochloric acid	0.1 M	7647-01-0/231-595-7
Isopropanol	70%	67-63-0/200-661-7
Triton-X 100	1%	9002-93-1/
Tween 20	1%	9005-64-5/500-018-3
Household detergent	5%	N/A

10 Reference information

10.2 Chemical resistance

Display

Chemical	Concentration	CAS no. /EEC no.
Aqueous buffers, pH 2 to pH 12	-	N/A
Decon90	10%	1310-58-3/215-181-3
Ethanol	20%	64-17-5/200-578-6
Hydrochloric acid	0.1 M	7647-01-0/231-595-7
Isopropanol	70%	67-63-0/200-661-7
Sodium chloride	1 M	7647-14-5/231-598-3
Sodium hydroxide	0.5 M	1310-73-2/215-185-5
Triton-X 100	1%	9002-93-1/
Tween 20	1%	9005-64-5/500-018-3
Spray with commercial house cleaning detergent.	5%	N/A

10.3 Literature

For further information related to ÄKTA start, refer to the following:

- *ÄKTA start Maintenance Manual*
- *UNICORN start User Manual*
- *ÄKTA start System Cue Card*
- *ÄKTA start Maintenance Cue Card*
- Data file

10.4 Health and Safety Declaration Form

On site service



On Site Service Health & Safety Declaration Form

Service Ticket #:	
--------------------------	--

To make the mutual protection and safety of GE service personnel and our customers, all equipment and work areas must be clean and free of any hazardous contaminants before a Service Engineer starts a repair. To avoid delays in the servicing of your equipment, please complete this checklist and present it to the Service Engineer upon arrival. Equipment and/or work areas not sufficiently cleaned, accessible and safe for an engineer may lead to delays in servicing the equipment and could be subject to additional charges.

Yes	No	Please review the actions below and answer "Yes" or "No". Provide explanation for any "No" answers in box below.
<input type="radio"/>	<input type="radio"/>	Instrument has been cleaned of hazardous substances. Please rinse tubing or piping, wipe down scanner surfaces, or otherwise ensure removal of any dangerous residue. Ensure the area around the instrument is clean. If radioactivity has been used, please perform a wipe test or other suitable survey.
<input type="radio"/>	<input type="radio"/>	Adequate space and clearance is provided to allow safe access for instrument service, repair or installation. In some cases this may require customer to move equipment from normal operating location prior to GE arrival.
<input type="radio"/>	<input type="radio"/>	Consumables, such as columns or gels, have been removed or isolated from the instrument and from any area that may impede access to the instrument.
<input type="radio"/>	<input type="radio"/>	All buffer / waste vessels are labeled. Excess containers have been removed from the area to provide access.
Provide explanation for any "No" answers here:		
Equipment type / Product No:		Serial No:
I hereby confirm that the equipment specified above has been cleaned to remove any hazardous substances and that the area has been made safe and accessible.		
Name:	Company or institution:	
Position or job title:	Date (WWW/MM/DD):	
Signed:		

GE and GE monogram are trademarks of General Electric Company.
 GE Healthcare Bio-Sciences Corp, 800 Centennial Avenue, P.O. Box 1327, Piscataway, NJ 08855-1327
 © 2010-14 General Electric Company—All rights reserved. First published April 2010.

DOC1149542/28-9800-26 AC 05/2014

Product return or servicing



Health & Safety Declaration Form for Product Return or Servicing

Return authorization number:		<i>and/or</i> Service Ticket/Request:	
-------------------------------------	--	---	--

To make sure the mutual protection and safety of GE personnel, our customers, transportation personnel and our environment, all equipment must be clean and free of any hazardous contaminants before shipping to GE. To avoid delays in the processing of your equipment, please complete this checklist and include it with your return.

1. Please note that items will NOT be accepted for servicing or return without this form
2. Equipment which is not sufficiently cleaned prior to return to GE may lead to delays in servicing the equipment and could be subject to additional charges
3. Visible contamination will be assumed hazardous and additional cleaning and decontamination charges will be applied

Yes	No	Please specify if the equipment has been in contact with any of the following:	
		Radioactivity (please specify)	
		Infectious or hazardous biological substances (please specify)	
		Other Hazardous Chemicals (please specify)	
Equipment must be decontaminated prior to service / return. Please provide a telephone number where GE can contact you for additional information concerning the system / equipment.			
Telephone No:			
Liquid and/or gas in equipment is:		Water	
		Ethanol	
		None, empty	
		Argon, Helium, Nitrogen	
		Liquid Nitrogen	
		Other, please specify	
Equipment type / Product No:		Serial No:	
I hereby confirm that the equipment specified above has been cleaned to remove any hazardous substances and that the area has been made safe and accessible.			
Name:		Company or institution:	
Position or job title:		Date (YYY/MM/DD)	
Signed:			

To receive a return authorization number or service number, please call local technical support or customer service.

GE and GE monogram are trademarks of General Electric Company.
GE Healthcare Bio-Sciences Corp, 800 Centennial Avenue, PO. Box 1327, Piscataway, NJ 08855-1327, US

© 2010-14 General Electric Company—All rights reserved. First published April 2010.
DOC1149544/28-9800-27 AC 05/2014

10.5 Ordering information

For ordering information visit www.gelifesciences.com/AKTASTart.

Accessories list

Part	Accessory description	Code no.
Pump	Marprene Tubing	29024012
	Peristaltic Pump	29023992
Solenoid valve	Buffer valve	29023895
	Sample valve	29023896
	Wash valve	29023897
	Outlet valve	29023898
Manual Injection valve	Injection valve , Manual	29023958
	Valve kit, Manual INV	29023917
Mixer	Mixer, ÄKTA start	29023960
UV	UV module, ÄKTA start	29024018
	Flow Cell 2 mm UPC-900	29011325
Conductivity	Conductivity Cell, ÄKTA start	29024021
Sample loops	Sample Loop 10 µl, PEEK	18112039
	Sample Loop 100 µl, PEEK	18111398
	Sample Loop 500 µl, PEEK	18111399
	Sample Loop 1.0 ml, PEEK	18111401
	Sample Loop 2.0 ml, PEEK	18111402
	Sample Loop 5 ml, PEEK	18114053
	Sample Loop 10 ml, FEP	18116124
Superloop	Superloop 10 ml	18111381
	Superloop 50 ml	18111382
	Superloop 150 ml	18102385

Part	Accessory description	Code no.
Fittings	Tubing Connector 1/8"	18112117
	Ferrule for 1/8" tubing	18112118
	Union Luer Female/HPLC Male	18111251
	Fingertight Connector 1/16"	18111255
	Stop plug 1/16", PKG/5	18111252
	Stop plug, 5/16", PKG/5	18111250
	Union, 1/16" female/1/16" female, for 1/16" o.d. tubing, titanium	18385501
	Union Valco F/F	11000339
	Fill port	18112766
Tubing	Inlet tubing Kit, ÄKTA start	29024032
	Complete tubing kit, ÄKTA start	29024034
	PEEK tubing i.d. 0.75 mm (1/16")	18111253
	PEEK tubing i.d. 1.0 mm (1/16")	18111583
	PEEK tubing, 2 m/i.d. 0.5 mm/o.d. 1/16"	18111368
Cables	Mains cable, 115 V	19244701
	Mains cable, 220 V	19244801
	Cable Assy OTH USB	29024036

10 Reference information

10.5 Ordering information

Part	Accessory description	Code no.
Miscellaneous	Inlet filter assembly	18111315
	Inlet filter set, 10 Filters/Nets	18111442
	Screw lid GL45 kit, ÄKTA	11000410
	Tubing cutter	18111246
	Column clamp o.d. 10 to 21 mm	28956319
	Short column holder	18111317
	T-Slot holders	29024038
	Buffer tray ÄKTA start	29024039
	Accessory Box	29024037
	Operating Instructions, printed	29155287
	Maintenance Manual, printed	29155290
	Injection kit	18111089
Software	UNICORN start DVD, license access code and manual package	29018751
Frac30	Frac30 Assembly	29023051
	Drive sleeve	19606702
	Tubing holder	18646401
	Bowl Assembly, Frac30	29024045
	Cable Assembly, Frac30	29024065

ÄKTA start spare parts

Item	Code no.
Packaging Kit for ÄKTA start	29032087
Packaging Kit for Frac30	29033703

Service tools

Item	Code no.
Torx driver T10	29003171
Torx driver T20	28951303
Flat screwdriver	56465600

11 Appendix

About this chapter

This appendix presents a template for a *Report of the **System performance method***. The Report has to be filled in with observations collected during the **System performance method**, which is performed either from ÄKTA start or from UNICORN start.

In this chapter

This chapter contains the following sections:

Section	See page
11.1 System Performance Report	269

11.1 System Performance Report

Test performed from ÄKTA start

Time (min)	Activity	Check	Approved interval	Observations
0	Pump wash	Wash valve position	Mobile phase out through Waste	
1	1 ml/min, 0% B, flow through Outlet valve , Waste position	Back pressure	≤ 0.05 MPa	
2	Repeat UV Auto zero			
3	5 ml/min	Back pressure	0.06 to 0.2 MPa	
		UV level	± 10 mAU	
		Conductivity level	± 1 mS/cm	
4	1 ml/min, Sample valve , Sample position	Max. UV level	300 to 380 mAU	
		Max. Conductivity level	65 to 95 mS/cm	
7	1 ml/min, Sample valve , Buffer position			
10	Request switch Injection valve to Inject position.	Max. UV level	300 to 380 mAU	
		Max. Conductivity level	65 to 95 mS/cm	
13	Request switch Injection valve back to Load position.			
15	Start gradient, 0 to100% B in 10 minutes, start fractionation/collection.			
19	End fractionation ¹	Weigh fraction no. 2, 3 and 4.	0.8 to 1.2 g	
		Max. diff. between fractions	0.1 g	

11 Appendix

11.1 System Performance Report

Time (min)	Activity	Check	Approved interval	Observations
20	End collection ²	Weigh beaker	4.2 to 5.8 g	
25	End gradient, stay at 100% B	Gradient	Straight, no negative dips.	
28	50% B	Gradient level ³	45 to 55% B	
36	0% B (Re equilibration)			
41	End	Check all connections for leakage	No leakages.	

1 With Fraction collector

2 Without Fraction collector

3 UV 50% B / UV 100% B

Test performed from UNICORN start

Time (min)	Activity	Check	Approved interval	Observations
1	1 ml/min, 0% B, flow through Outlet valve waste position	Back pressure	≤ 0.05 MPa	
2	Repeat UV Auto zero			
3	5 ml/min	Back pressure	0.06 to 0.2 MPa	
15	Start gradient, 0 to 100% B in 10 minutes, start fractionation/collection.			
19	End fractionation ¹	Weigh fraction no. 2, 3 and 4.	0.8 to 1.2 g	
		Max. difference between fractions	0.1 g	
20	End collection ²	Weigh beaker	4.2 to 5.8 g	
25	End gradient, stay at 100% B	Gradient ³	Straight, no negative dips.	
41	End	Check all connections for leakage	No leakage.	

- 1 With Fraction collector
- 2 Without Fraction collector
- 3 UV 50%B / UV 100%B

Index

A

- Abbreviations, 20
- ÄKTA start
 - instrument main parts, 41
 - instrument modules, descriptions, 44
 - intended use, 40
 - main features, 43
 - system description, 40

B

- BMP result file, 196

C

- Calibrations
 - calibration guide, 93
- CE
 - conformity, 12
 - marking, 12
- Chromatogram
 - view, 153
- Cleaning
 - Conductivity flow cell, 218
 - Inlet filters, 223
 - UV flow cell, 216
- Clean the system, 180
- Cold room
 - operations, 138
- Column
 - connect, 110
 - disconnect, 212
 - placement, 109
- Column preparation, 121
- Conductivity flow cell
 - cleaning, 218
- Create method, 184

E

- Emergency procedures
 - emergency shutdown, 34
 - power failure, 35
- Evaluate a run, 180
- Export method, 194

F

- Flow path
 - inlet and outlet tubing, 90
- Frac30
 - delay volume setting, 136
 - main parts, 42
 - preparation, 134
- Fractionation, 146
- Fraction collector
 - cleaning, 225

I

- Import
 - method, 195
 - result file, 194
- Important user information, 9
- Injection valve
 - description, 124
- Installation
 - connect a computer, 85
 - connect Frac30, 83
 - connect power, 82
 - pump tubing, 81
 - site requirements, 65
 - Unpack ÄKTA start, 69
 - Unpack Frac30, 73
- Instrument display
 - function, 49
- Instrument Display
 - Create method screen, 56
 - help, 52
 - Method run screen, 53
 - overview, 48
 - Settings and service screen, 57
 - touch buttons, 49

L

- Literature, 261

M

- Maintenance, 205
 - cleaning before service, 209
 - clean the instrument, 223–224

- disconnect column, 212
- long term storage, 229
- Prepare system methods, 177
- Pump wash A, 114
- Pump wash B, 116
- replacement procedures, 222, 230
- short term storage, 228
- System cleaning**, 177, 213
- Washout fractionation tubing, 118
- Manage files
 - USB memory stick, 193
- Manage methods
 - create a method, 185
 - delete a method, 192
 - edit a method, 188
 - import a method, 190
- Manual run
 - edit, 154
 - end, 157
 - pause, 156
 - start a run, 150
- Manufacturing information, 11
- Method run
 - hold, 165
 - method types, 159
 - Quick start, 161
 - select a method, 160
 - start a run, 162
 - templates, 167
 - user defined methods, 175
- N**
- Nomenclature conventions, 8
- Notes and tips, 10
- O**
- Operations
 - checklist, 144
 - cold room, 138
 - from the instrument display
 - Manage methods, 183
 - perform a manual run, 149
 - perform a method run, 158
 - from UNICORN start, 198
 - monitor the run, 153
 - workflow, 143
- P**
- Power off, 182
- Priming
 - sample loop, 128
 - sample tubing, 126
- Pump
 - install tubing, 81
- Pump wash A
 - instructions, 114
- Pump wash B
 - instructions, 116
- Purpose of this document, 8
- R**
- Recycling
 - procedures, 36
- Recycling information
 - decontamination, 36
 - disposal of electrical components, 36
- Reference information
 - ordering information, 264
 - recycling, 36
- Regular maintenance, 206
- Regulatory compliance, 16
- Regulatory information, 11
- Run parameters
 - specifications, 257
- S**
- Safety notices, 10
- Safety precautions
 - emergency procedures, 34
 - flammable liquids, 23
 - general precautions, 22
 - introduction, 22
 - labels, 30–31
 - personal protection, 23–24
- Sample application
 - alternatives, 123
 - from Pump, 127
 - sample loop, 128
 - Superloop, 132
- Sample loop
 - connection, 125
 - load sample, 129
 - priming, 128
- Service and settings

- maintenance schedule, 206
- Specifications, 252
- Standards, 15
- Starting a run
 - final checks, 140
- Storage, 181
- Superloop
 - connection, 125
- Switch valve timing
 - settings, 107
- System cleaning, 213
- System error repor
 - generate, 249
- System performance
 - acceptance criteria, 100, 102
 - switch valve timing, 105
 - system performance method, 95
 - system performance method from ÄKTA start, 98
 - system performance method from UNICORN start, 102

T

- Templates
 - Affinity (AC) or Ion exchange (IEX), 168

- Gel filtration, Desalting/Buffer Exchange, 171
 - predefined, 167
- Troubleshooting
 - basic, 237
 - procedure, 235
 - system error report, 249
 - User information messages, 246
- Tubing
 - replace tubing, 232
- Typographical conventions, 8

U

- UNICORN start
 - overview, 198
- Unpacking
 - accessories package, 79
- USB memory stick
 - troubleshooting, 248
- User information messages, 246
- UV flow cell
 - cleaning, 216

W

- Washout fractionation tubing
 - instructions, 118
- Workflow, 143

Page intentionally left blank

For local office contact information, visit
www.gelifesciences.com/contact

GE Healthcare Bio-Sciences AB
Björkgatan 30
751 84 Uppsala
Sweden

www.gelifesciences.com/AKTastart

GE, the GE Monogram, ÄKTA, HiPrep, HiTrap, Sephacryl, Superloop and UNICORNare trademarks of General Electric Company.

Decon is a trademark of Decon Laboratories Ltd. Deconex is a trademark of Borer Chemie AG Zuchwil, Switzerland. Eppendorf is a trademark of Eppendorf AG. Falcon is a trademark of Becton, Dickinson and Company. Macintosh is a trademark of Apple Inc. Marprene is a trademark of Watson-Marlow Limited. Microsoft and Windows are registered trademarks of Microsoft Corporation. RBS is a trademarks of Chemical Products R. Borghgraef S.A. Triton is a trademark of Union Carbide Chemicals and Plastic Company Inc. Tween is a trademark of Uniqema Americas LLC.

All other third party trademarks are the property of their respective owners.

Any use of UNICORN start is subject to GE Healthcare Standard Software End-User License Agreement for Life Sciences Software Products. A copy of this Standard Software End-User License Agreement is available on request.

UNICORN start © 2013-2016 General Electric Company

© 2013-2017 General Electric Company.
First published Sept. 2013

All goods and services are sold subject to the terms and conditions of sale of the company within GE Healthcare which supplies them. A copy of these terms and conditions is available on request. Contact your local GE Healthcare representative for the most current information.

GE Healthcare Europe GmbH
Munzinger Strasse 5, D-79111 Freiburg, Germany

GE Healthcare UK Limited
Amersham Place, Little Chalfont, Buckinghamshire, HP7 9NA, UK

GE Healthcare Bio-Sciences Corp.
100 Results Way, Marlborough, MA 01752, USA

GE Healthcare Dharmaco, Inc.
2650 Crescent Dr., Lafayette, CO 80026, USA

HyClone Laboratories, Inc.
925 W 1800 S, Logan, UT 84321, USA

GE Healthcare Japan Corporation
Sanken Bldg. 3-25-1, Hyakunincho Shinjuku-ku, Tokyo 169-0073, Japan

