

HERMLE Z 366

User Manual

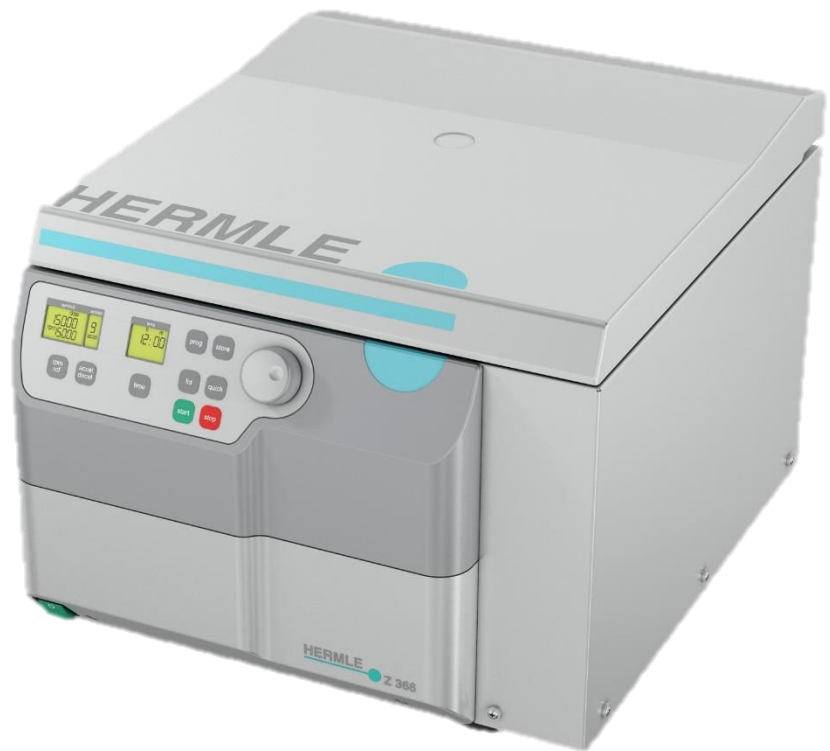



HERMLE Labortechnik GmbH
Siemensstraße 25
78564 Wehingen
Tel: +49 (0) 74 26-96 22-11
Fax: +49 (0) 74 26-96 22-49
Email: info@hermleL.T.de
Internet: <http://www.hermle-labortechnik.de>

Technical rights reserved
©HERMLE Labortechnik GmbH 2024

1. PRODUCT DESCRIPTION	1
1.1 Safety Instructions	1
1.2 Intended Purpose	1
1.3 Contraindication	1
1.4 Brief Description.....	1
1.5 Delivery Package	1
1.6 Operating and Display Elements.....	2
1.6.1 LCD-Display	3
1.7 Signs and Indications of the Centrifuge	4
1.7.1 General.....	4
1.7.2 Product Nameplate (Example)	4
1.7.3 Warning and Information Signs	5
1.7.4 Danger, Precautions and Warranty	5
1.7.5 Following Rules Must Strictly be Adhered To:.....	6
1.7.6 Warranty.....	6
1.8 Installation of the Centrifuge	7
1.8.1 Unpacking the Centrifuge	7
1.8.2 Space Requirements	7
1.8.3 Installation	7
1.8.4 Attention before first use!.....	8
1.9 Basic Adjustments	9
1.9.1 Access to Mode: "Operating Data"	9
1.9.2 Sound Signal Turn On / Off	10
1.9.3 Volume Pre-Selection of Sound Signal	10
1.9.4 Song Selection - End of Run	11
1.9.5 Keyboard Sound Turn On / Off.....	11
1.9.6 Retrieving Operating Data (operated by skilled or service engineer only!).....	12
2. OPERATION	13
2.1 Mounting and Loading the Angle Rotor	13
2.1.1 Installation of Rotors.....	13
2.1.2 Loading Angle Rotors.....	13
2.1.3 Loading Swing Out Rotors.....	14
2.1.4 Loading and Overloading of Rotors.....	15
2.1.5 Removing the Rotor	15
2.2 Lid	16
2.2.1 Lid Release	16
2.2.2 Lid Lock.....	16
2.3 Pre-Selection.....	17
2.3.1 Pre-Selection of Speed / RCF-Value.....	17
2.3.2 Pre-Selection of Running Time.....	17
2.3.3 Pre-Selection of Brake Intensity and Acceleration.....	18
2.4 Radius Correction.....	19
2.5 Program.....	19

2.5.1	Storage of Programs	19
2.5.2	Recall of Stored Programs	20
2.5.3	Leaving Program Mode	21
2.6	Starting and Stopping the Centrifuge	21
2.6.1	Starting the Centrifuge.....	21
2.6.2	The "STOP" Key.....	22
2.7	Imbalance Detection	23
2.8	Timer Function.....	23
3.	MAINTENANCE	25
3.1	Maintenance and Cleaning.....	25
3.1.1	General Care:.....	25
3.1.2	Cleaning and Disinfecting of the Unit	26
3.1.3	Cleaning and Disinfecting of the Rotor	26
3.1.4	Disinfection of Aluminum Rotors	26
3.1.5	Disinfection of PP-Rotors	26
3.1.6	Glass Breakage.....	27
3.2	Lifetime of Rotors, Round and Rectangular Buckets, Accessories.....	27
4.	TROUBLE SHOOTING	28
4.1	Error Message: Problem / Solution	28
4.2	Survey of Possible Error Messages and Solutions	28
4.2.1	Lid Release during Power Failure (Emergency Lid Release)	28
4.2.2	Description of the Error Message System	29
4.2.3	Procedure while error 14, from software version 1.76	29
4.2.4	Procedure while error 38 – Lid motor is blocked	30
5.	RECEIPT OF CENTRIFUGES FOR REPAIR.....	31
6.	TRANSPORT, STORAGE AND DISPOSAL.....	32
6.1	Transport.....	32
6.2	Storage	32
6.3	Disposal.....	32
7.	APPENDIX.....	III
	Table 1: Technical Data	IV
	Table 2: Permissible Net Weight.....	V
	Table 3: Max. Speed and RCF-Values for Permissible Rotors	V
	Table 4: Acceleration and Deceleration Times.....	VI
	Table 5: Error Messages.....	VII
	Table 6 (Part 1): Radius Correction.....	VIII
	Table 6 (Part 2): Radius Correction.....	IX
	Table 6 (Part 3): Radius Correction.....	X
	Table 7: Abbreviations	X
	Redemption Form / Decontamination Certificate	XI

1. PRODUCT DESCRIPTION

1.1 Safety Instructions



This symbol indicates safety instructions and points of potential dangerous situations. Before using the centrifuge for the first time, please read the operating manual.

Failure to follow these instructions can result in personal injury and/or property damage.

Intended use includes the observation of all instructions, in the instruction manual, and administering inspection and maintenance.

1.2 Intended Purpose

This HERMLE centrifuge and its accessories are an in vitro diagnostic medical device within the meaning of the In Vitro Diagnostic Medical Devices Regulation (EU) 2017/746. This centrifuge is intended for the separation of mixtures of substances of different densities, in particular for the preparation and processing of samples from the human body in the context of an in vitro diagnostic application, in order to enable the intended use of the in vitro diagnostic medical device.

HERMLE centrifuges are intended exclusively for use in closed rooms under supervision and for operation by trained specialist personnel.

Only original HERMLE rotors and buckets and other accessories may be used. Any other use or use beyond this is considered improper use. HERMLE Labortechnik GmbH is not liable for any resulting damage. The contents of the operating instructions must be observed.

1.3 Contraindication

The HERMLE centrifuge and its accessories are intended exclusively for the above-mentioned purpose and must not be used to determine any measured values. After centrifugation, no components of human origin may be implanted or administered back into the body.

1.4 Brief Description

The unit type Z 366, is a non refrigerated universal centrifuge, which we offer in two voltage variations 230V or 120V.

The centrifuge can be used with swing-out rotors and angle rotors.

All parameters are accessible via buttons, and selected with a central adjuster. All pre-selected and current values will be shown, permanently, on the LCD-Display.

The centrifuge is powered by a Maintenance-Free Induction Motor.

Detailed technical data are in Table 1: "Technical Data" (see APPENDIX P.V).

1.5 Delivery Package

- 1 Centrifuge Z 366
- 1 Operating Manual Z 366
- 1 Rotor key

*Rotor(s) / Accessories will be packaged separately.

1.6 Operating and Display Elements

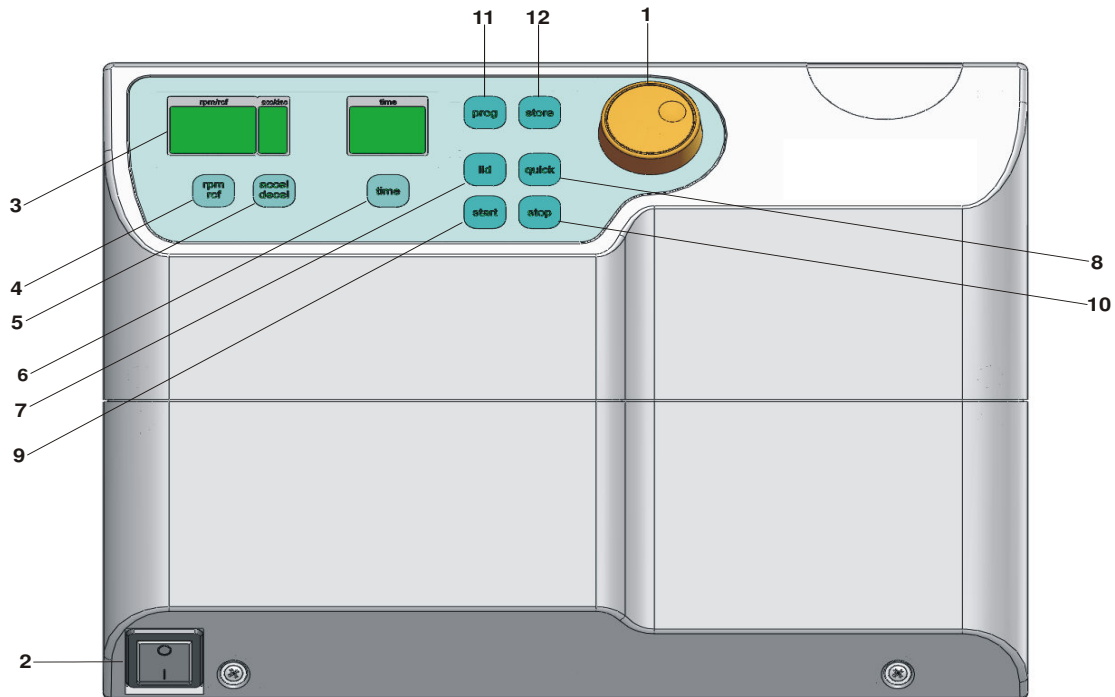

- | | | |
|----|-------------------------|---------------------------------------|
| 1 | central adjuster | Run Parameters |
| 2 | 0-I | Power Switch |
| 3 | LCD | Control Panel Display |
| 4 | rpm/rcf | Speed/ g-Force |
| 5 | accel/decel | Acceleration / Deceleration Intensity |
| 6 | time | Centrifugation Time |
| 7 | lid | Lid Release |
| 8 | quick | Short Running |
| 9 | start | Start Centrifugation |
| 10 | stop | Stop Centrifugation |
| 11 | prog | Retrieving Stored Programs |
| 12 | store | Program Store |

1.6.1 LCD-Display

The following picture shows the individual elements of the LCD-display.

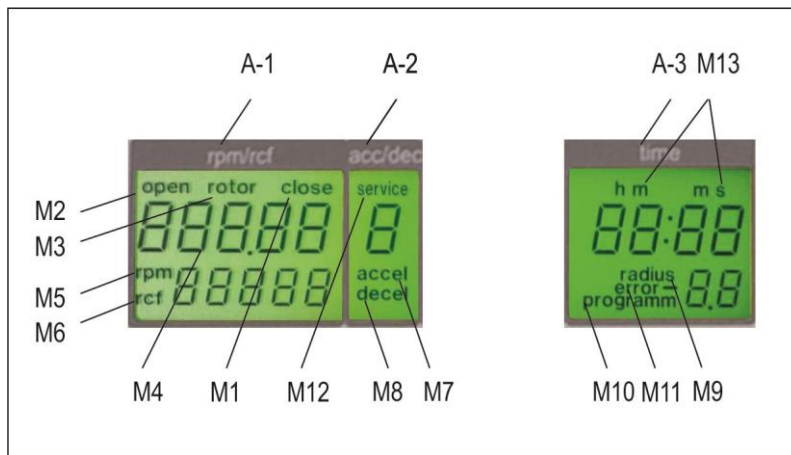

Figure 1

Display Fields:

- A-1 Display Field – "rpm/rcf"
- A-2 Display Field – "acc/dec"
- A-3 Display Field – "time"

Messages/Logos of the Display Fields:

- | | | | |
|----|-----------|-----|-----------|
| M1 | "close" | M8 | "decel" |
| M2 | "open" | M9 | "radius" |
| M3 | "rotor" | M10 | "program" |
| M4 | Rotor-No. | M11 | "error" |
| M5 | "rpm" | M12 | "service" |
| M6 | "rcf" | M13 | h m s |
| M7 | "accel" | | |

Indication:

After switching on the centrifuge, the display, "rpm/rcf"(A-1) shows the loading status, the current software version and finally the model type (e.g. Z 36 HK).



1.7 Signs and Indications of the Centrifuge

1.7.1 General



Instructions for Disposal (see P. 28)



Direction of Rotation – clockwise rotation for the rotor drive



Reference for Loading Rotors

1.7.2 Product Nameplate (Example)



Company Address: Hermle Labortechnik GmbH, Siemensstr. 25, D-78564 Wehingen

IVD In-Vitro-Diagnostic Medical Device

TYPE: Type Designation of the Product

REF: Order No. of the Product

SN: Serial No. of the Product



Manufacturer



Date of Manufacture

MAX. Drehzahl: Max. Speed Allowed of the Unit

KIN. EN.: Max. Kinetic Energy with Corresponding Roto

U//I/f: Allowable Voltage / Max. Current / Frequency

P: Electrical Input Power



Operating Manual Indication



UK-Conformity Assessed



Labeling, Standards and Guidelines



RoHS Conformity

1.7.3 Warning and Information Signs

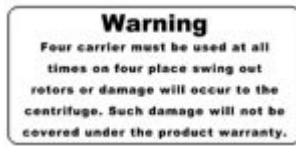

Four microtiter carriers must be used at all times on four places swing out rotors or damage will occur to the centrifuge. Such damage will not be covered under the product warranty



Attention! Check the fastening of the rotor nut before each run



Take off mains plug before opening the housing or the emergency release



Power Input



Rotation Direction Emergency Release



Biohazard Warning

1.7.4 Danger, Precautions and Warranty



This device may only be operated by a trained professional. Carefully, read the operating manual and be familiar with the functions of the device.

To protect people and the environment, the following precautions must be taken:

- During centrifugation, the presence of people and the arrangement of hazardous materials is strictly prohibited, within 30 cm/12 in around the centrifuge, according to the regulations of EN 61010-2-020.
- The HERMLE **Z 366** is "non explosion-proof" and must not be operated in explosion-endangered areas or locations. Centrifugation of flammable, explosive, radioactive, or such substances, which chemically react with high energy, is strictly prohibited. If used in such environment, this is at the users own expense.
- Never spin toxic or pathogenic material without adequate safety precautions, i.e. centrifugation of buckets / tubes with or without defective hermetic sealing, is strictly prohibited. The user is obliged to perform appropriate disinfection procedures, in case dangerous substances have contaminated the centrifuge and/or its' accessories. When centrifuging infectious substances, always pay attention to the General Laboratory Precautions. If necessary, contact your safety officer!
- It is prohibited to run the centrifuge, with rotors not manufactured for this unit.
- Under no circumstances open the lid of the centrifuge, while the rotor is still running or rotating with a speed of > 2m/s

1.7.5 Following Rules Must Strictly be Adhered To:

- Do not operate the centrifuge if not installed correctly.
- Do not operate the centrifuge when dismantled (e.g. without housing).
- Do not run the centrifuge, if mechanical or electrical assembly groups have been tampered with, by unauthorized personnel.
- Do not use accessories such as rotors and buckets, that are not approved by HERMLE Labortechnik GmbH, except commercially available centrifuge tubes, made of glass or plastic.
- Do not spin extremely corrosive substances, as they may cause material damages and impair mechanical resistance.
- Do not operate the centrifuge with rotors or buckets, that show any signs of corrosion or mechanical damage.

The manufacturer is responsible for safety and reliability, of the centrifuge, only if:

- The unit is operated in accordance to this instruction manual.
- Modifications, repairs or other adjustments are performed by HERMLE-authorized personnel and the electrical installation of the related location corresponds to the IEC-regulations.

1.7.6 Warranty

The centrifuge has been subjected to thorough testing and quality control. In the unlikely case of any manufacturing faults occurring, the centrifuge and rotors are covered by warranty, for a period of two years, from date of delivery. This warranty becomes invalid in any case of mishandling, damage and/or negligence and further in any case of usage of inappropriate spare parts and / or accessories or unauthorized modification of the unit.

Technical modification rights are reserved, by the manufacturer, in regards to technical improvement!

1.8 Installation of the Centrifuge

1.8.1 Unpacking the Centrifuge

Model Z 366 is supplied in a carton.

Remove the strap retainer, open the carton, and remove the padding.

Lift the centrifuge on both sides (see Figure 1) with an appropriate number of helpers and place it on the laboratory table.



Attention! Do not lift the centrifuge from under the lid or by the front panel!



Figure 1

The instruction manual must be kept with the centrifuge, at all times!

1.8.2 Space Requirements

The centrifuge should be installed on an even, solid surface, if possible on a laboratory cabinet / table or some other solid vibration free surface.

During centrifugation, the centrifuge must be placed in a way, that there is a minimum space of 30 cm/11.81in on each side of the unit, according to EN 61010-2-020 standards.

Do not place the centrifuge next to a window or a heater where it could be disposed to excessive heat, as the performance of the unit is based on an ambient temperature of 23°C/73.4°F.

1.8.3 Installation

Follow These Steps:

- Check whether the power supply corresponds with the one specified on the manufacturer's rating label, mounted on the rear panel.
- The power connection for the centrifuge requires a **separate** one-site protection, with 16 A (Type K)
- In case of emergency, there must be an emergency switch off installed outside of the room, in order to disconnect the power supply from the unit.
- Connect the centrifuge, with the mains.

(The socket for the power cord must be easy to reach, respectively easy to disconnect).

Switch on, by using the mains power switch (I).

Open the lid, by using the button LID.

- Remove the transport securing device of the motor.

1.8.4 Attention before first use!

Depending on how the motor shaft of your centrifuge is looking like, some action must be taken before the first operation. Please note the shape of the motor shaft of your centrifuge. There are two different versions:

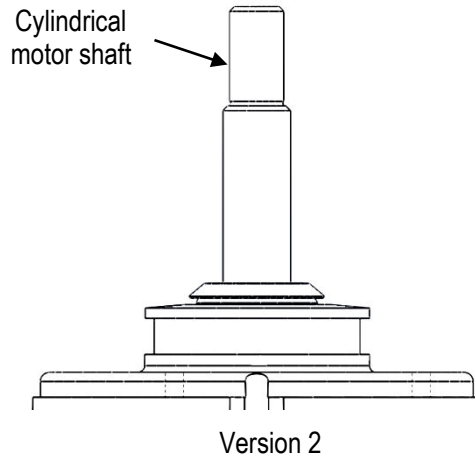
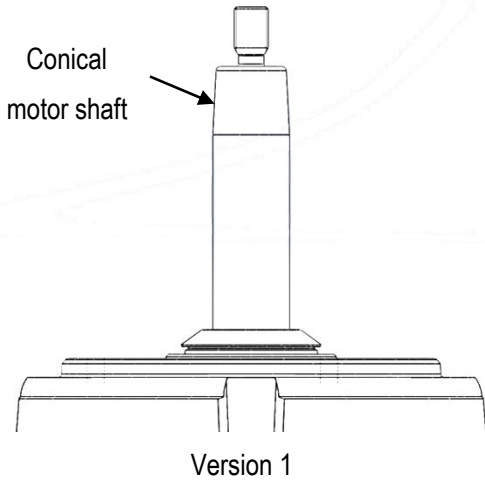

<p>If the motor shaft is conical</p>	<p>remove the collet from the rotor by turning it counter clockwise</p>	<p>The collet is no longer needed</p>	
<p>If the motor shaft is cylindrical</p>	<p>Let the collet inside the rotor</p>		

1.9 Basic Adjustments

At commissioning of the centrifuge, you have the options to make the following basic changes:

- Acoustic Signal Turn On / Off
- Keyboard Sound Turn On / Off
- Volume Pre-Selection of Sound Signal
- Song Selection - "End of Run"

1.9.1 Access to Mode: "Operating Data"

If the centrifuge is still turned off, press the keys, "time" (6) and "lid" (7) simultaneously, turning on the main switch of the centrifuge. Now release both keys. As a result, a display test is administered for approx. 5 seconds. All possible indications will appear at the same time (see Figure 2).

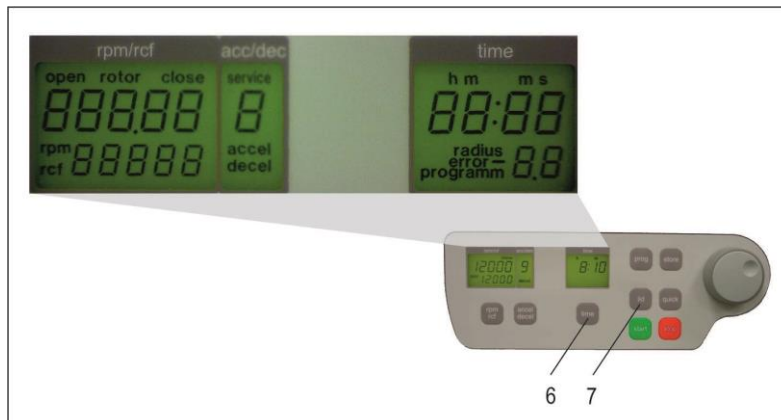

Figure 2

 Attention:

- Please notice that you must enter the program as described, under point 1.9.1, to change the adjustments of the points 1.8.2 - 1.8.6. After the settings have been stored by user, the normal program mode can be changed back again by switching off the centrifuge, for a short period.
- All changed settings must be confirmed by the key, "start" (9). A confirmation screen will appear with the word; "store" in the display box, "rpm/rcf"(A-1) - Only then, the pre-selections are valid, (see Figure 3)!

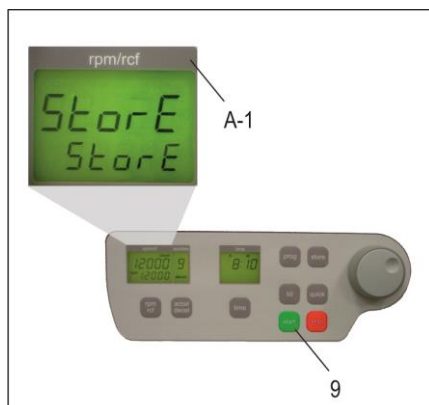

Figure 3

1.9.2 Sound Signal Turn On / Off

Proceed as illustrated, under point 1.8.1, to enter this program mode, press the key; "accel/decel" (5). In the display, "accel/decel" (A-2) flashes the word, "service". Select the letter, "L" with the adjustable knob (1). As a result, appearing in the display "rpm/rcf" (4), are the words, "On Sound". By pressing the key, "rpm/rcf" (4), the word "On" flashes, and the sound can be switched off with the adjustable knob (1), (see Figure 4).

After the settings have been stored by user, the normal program mode can be changed back again by switching off the centrifuge, for a short period.

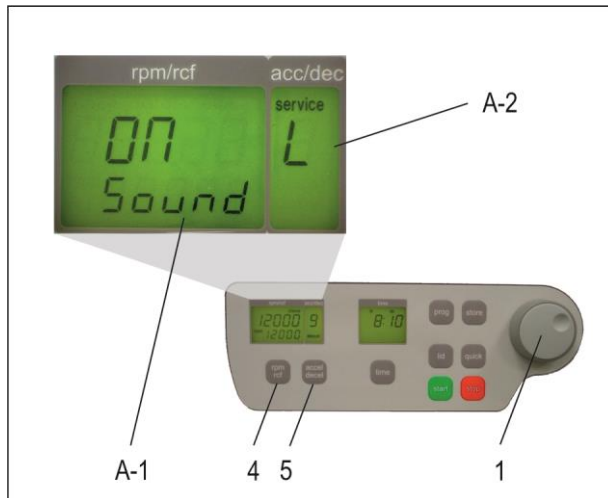

Figure 4

1.9.3 Volume Pre-Selection of Sound Signal

Proceed as illustrated, under point 1.8.1, to enter this program mode, press the key "accel/decel" (5). In the display, "accel/decel" (A-2), flashes the word, "service". Select the letter, "U" with the adjustable knob (1). As a result, appearing in the display, "rpm/rcf" (A-1), are the words, "Vol=0-9/Sound". By pressing the key, "rpm/rcf" (4), the desired volume can be adjusted between 0 (low) and 9 (loud), with the adjustable knob (1), (see Figure 5).

After the settings have been stored by user (see 1.8.1), the normal program mode can be changed back again by switching off the centrifuge, for a short period.

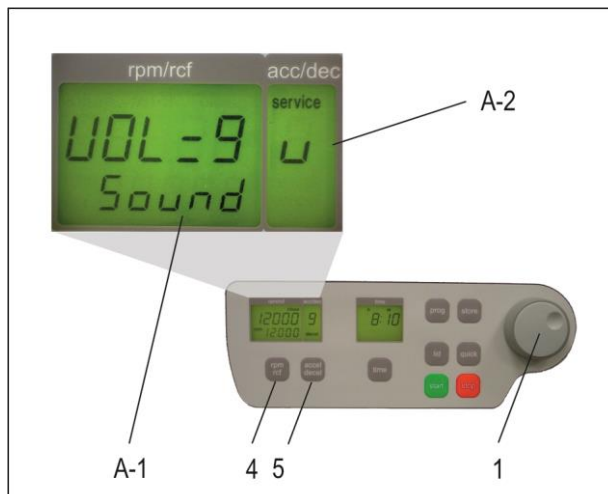

Figure 5

1.9.4 Song Selection - End of Run

Proceed as illustrated, under point 1.8.1, to enter this program mode, press the key, "accel/decel" (5). In the display, "accel/decel" (A-2) flashes the word, "service". Select the letter, "G" with the adjustable knob (1). As a result, appearing in the display, "rpm/rcf" (A-1), the word "SonGo/Sound". After pressing the key „rpm/rcf“ (4), select a song with the adjusting knob (1), (see Figure 6).

After the settings have been stored by user (see 1.8.1), the normal program mode can be changed back again by switching off the centrifuge, for a short period.

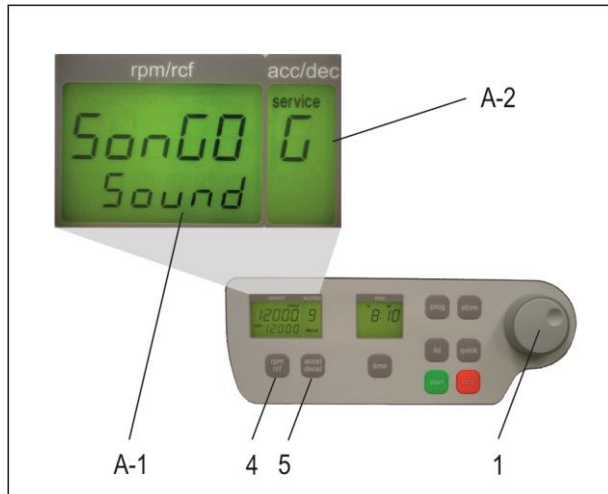

Figure 6

1.9.5 Keyboard Sound Turn On / Off

Proceed as illustrated, under point 1.8.1, to enter this program mode, press the key, "accel/decel" (5). In the display; "accel/decel" (A-2) flashes the word, "service". Select the letter, "b" with the adjustable knob (1). As a result, appearing in the display, "rpm/rcf" (A-1), the word "ON/BEEP". By pressing the key, "rpm/rcf" (4), the keyboard sound (On) or (Off) can be turned on, with the adjustable knob (1), (see Figure 7).

After the settings have been stored by user (see 1.8.1), the normal program mode can be changed back again, by switching off the centrifuge, for a short period.

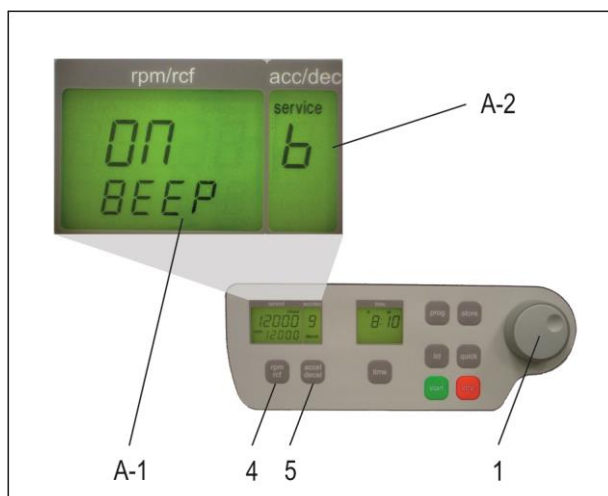

Figure 7

1.9.6 Retrieving Operating Data (operated by skilled or service engineer only!)

In the function, "Basic Adjustments", retrieving the operating data of the centrifuge is an available option. Please proceed as illustrated, under point 1.8.1, to enter this program mode, press the key, "accel/decel" (5). In the display, "accel/decel" (A-2) flashes the word, "service".

With the adjustable knob (1), the following information can be retrieved:

- A = Previous Starts of the Centrifuge
- H = Previous Operating Hours
- S = Software Version
- r = Converter Software
- E = List of Previous Error Message
- h = Running Time of the Motor

The list of the last 99 error messages can be reviewed by pressing the key, "rpm/rcf" (4) and scroll through, with the adjustable knob (1). The respective error codes appear in the display, "rpm/rcf" (A-1). Please refer to Table 6: "Error Messages", (see APPENDIX P.VIII).

Switch off the centrifuge, to return to the normal program mode.

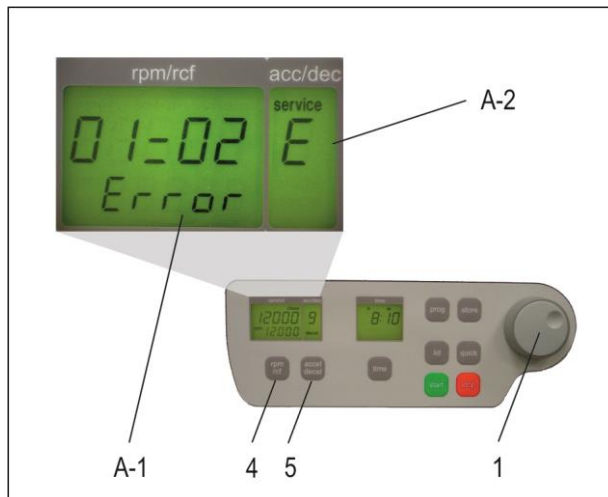

Figure 8

2. OPERATION

2.1 Mounting and Loading the Angle Rotor

2.1.1 Installation of Rotors

Clean the drive shaft and the collet with a clean, grease-free piece of cloth. Place the rotor onto the drive shaft, (see Figure 9). Please be sure that the rotor is fully installed onto the motor shaft.



Figure 9



Figure 10

Hold the rotor with one hand and secure the rotor to the shaft, by turning the fixing nut clockwise. Tighten the fixing nut with the provided Allen key, (see Figure 10)

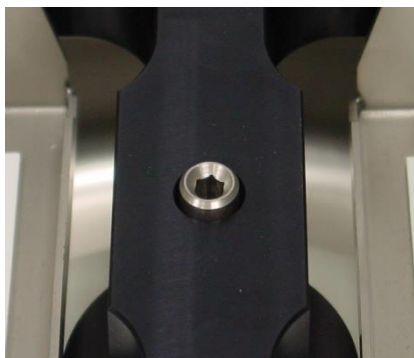

Figure 11

⚠ ATTENTION: For safety, always ensure that the rotor fixing screw is tightened before each run, (see Figure 10)!!

2.1.2 Loading Angle Rotors

Rotors must be loaded symmetrically and with equal weight. The adapter may only be loaded with the appropriate vessels. The weight differences between the filled vessels should be kept as low as possible. Therefore, we recommend to weigh with a balance. This reduces the wear of drive and the acoustic operating noise.

Each rotor indicates what the maximum capacity is per hole.



Attention:

For safety reasons, all places on certain rotors must be occupied with equal weight during centrifugation (See Figure 13.).



Figure 1 *wrong*



Figure 2 *right*

Regardless of the centrifuge model, this applies to the following angular rotors:

- 221.51 (4 x 500 ml)
- 221.21 (6 x 250 ml)
- 220.78 (6 x 85 ml)
- 221.18 (6 x 85 ml)
- 221.20 (4 x 85 ml)

2.1.3 Loading Swing Out Rotors

Loading of the buckets / vessels must be done in accordance, to Figure 15.

It is allowed to operate e.g. a 4-place-rotor with 2 loaded buckets only. The loaded buckets must be opposite of each other. Make sure that the unloaded buckets are placed inside the rotor, (see Figures 14 and 15).

In principle, swing out rotors cannot be removed during operation, until all buckets or racks are placed inside the rotor.

The bolts of the rotor must be greased with the HERMLE Rotorgrease (Order No. 38-5656). The sample tubes have to be filled evenly, by eye, and set into the drillings or tube racks. The weight difference of the loaded buckets should not exceed 1.0 g.



ATTENTION!

Swing Out Rotors can be removed during operation, only if all locations are filled in with either 4 buckets or 4 microtiter carriers – do not mix up buckets and microtiter carriers!

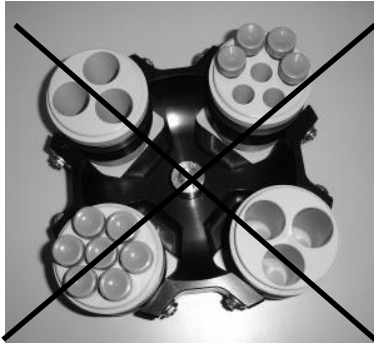

Figure 14: WRONG



Figure 15: RIGHT

**ATTENTION!**

Do not operate the centrifuge with rotors or buckets that show any signs of corrosion or mechanical damage.

Do not operate with extremely corrosive substances, which could damage the rotor and buckets.

In case of any questions, please contact the manufacturer!

2.1.4 Loading and Overloading of Rotors

All approved rotors are listed with their maximum speed and maximum filling weight, in Table 2: "Permissible Net Weight", (see APPENDIX P. VI).

The maximum load permitted for a rotor is determined by the manufacturer, as well as the maximum speed allowed for this rotor (see label on rotor), must not be exceeded. The liquid the rotors are loaded with, should have a max. homogeneous density of 1.2 g/ml or less when the rotor is running at maximum speed.

In order to spin liquids with a higher density, the speed has to be reduced, according to the following formula:

$$\text{Reduced speed } n_{\text{red}} = \sqrt{\frac{1,2}{\text{higher density}}} \times \text{max. speed } (n_{\text{max}}) \text{ of the rotor}$$

Example:

$$n_{\text{red}} = \sqrt{\frac{1,2}{1,7}} \times 4.000 = 3.360 \text{ rpm}$$

In case of any questions, please contact the manufacturer!

2.1.5 Removing the Rotor

Completely, untighten the rotor fixing nut (2. screw over the stiff point) and lift the rotor vertically out of the centrifuge, (see Figures 9 and 10).

2.2 Lid

2.2.1 Lid Release

After the run, properly close the lid of the centrifuge, appearing in the display, "rpm/rcf"(A-1) with the word, "close" (M1). If there is a rotor in the centrifuge, the word, "rotor" (M3) appears, as well as the code number of the specified rotor, which is in the centrifuge, for example "221.28" (M4). If there is no rotor in the centrifuge, it flashes the word, "rotor" (M3) and an additional word, "no" (M4). By pressing the key, "lid" (7), the lid of centrifuge can be released. As soon as the electromagnetic lid is completely released, the word, "open" (M2) appears. The lid of the centrifuge is now able to be opened.

For all number marked text, please refer to Figure 16.

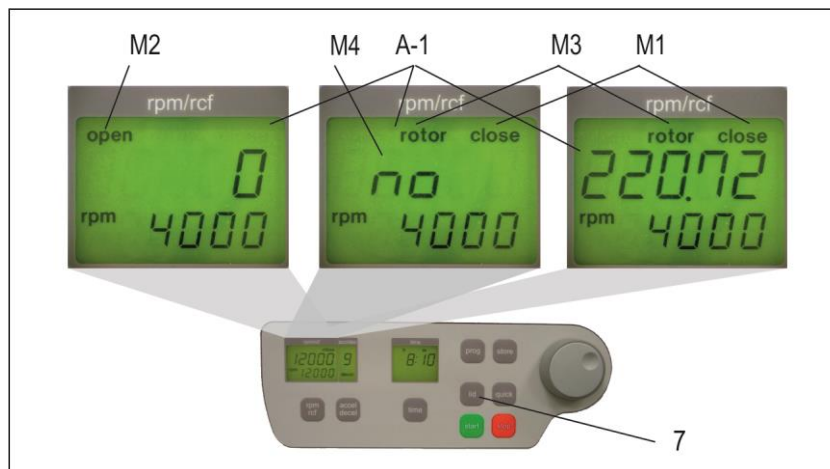

Figure 16

During the run, you can retrieve the rotor type at any time, by pressing the key, "lid" (7).

2.2.2 Lid Lock

The lid must only be closed slightly. An electromagnetic lid lock closes the lid, the word "open" (M2) will no longer be displayed.

As a sign that the centrifuge is ready for starting, appearing in the display, "rpm/rcf"(A-1), the word "close" (M1). Simultaneously, the word "rotor" (M3) appears, as well as the code number of the rotor, which is in the centrifuge, i. e. "nr 22x.xx" (M4), along with all rotor specific data, for example: max. speed, acceleration etc., are available.

For all number marked text, please refer to Figure 16.



ATTENTION: Don't grip your fingers between the lid and the device or the locking mechanism, when closing the lid!

2.3 Pre-Selection

2.3.1 Pre-Selection of Speed / RCF-Value

Selecting the key, "rpm/rcf" (4), pre-selection is activated. By pressing the key once, the word "rpm" (M5) flashes. By pressing the key again, the pre-selection of the centrifugal forces can be chosen. The flashing word, "rcf" (M6), will appear. The desired values can be selected, with the adjustable knob (1). In the display (A-1), the regulated value is shown permanently: before, during and after the run.

For all number marked text, please refer to Figure 17.

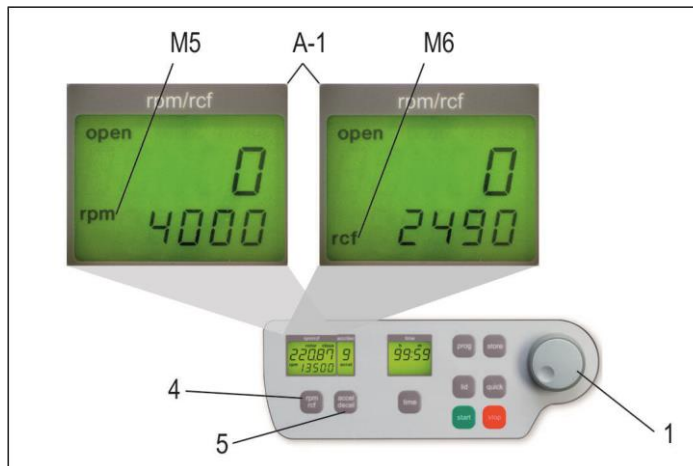

Figure 17

As long as no rotor is inserted, the speed is adjustable between 200 rpm and the maximum revolution of the centrifuge.

If there is a rotor in the centrifuge, the speed can only be pre-selected up to the maximum permissible revolution of that rotor. It is the same with the pre-selection of the RCF-Value. The setting range is between 20 xg and the maximum permissible centrifugal force of the rotor.

See Table 3: "Max. Speed and RCF-Values for Permissible Rotor", (see APPENDIX P. VI). All important values are listed on this table.



ATTENTION:

Please check the maximum permissible revolutions of your test tubes! (Producer Indication).

2.3.2 Pre-Selection of Running Time

The running time can be pre-selected in 3 different ranges: from 10 seconds up to 99 hours 59 minutes.

1. Range from: 10 seconds up to 59 minutes 50 seconds, in steps of 10 seconds
2. Range from: 1 hour up to 99 hours 59 minutes, in steps of 1 minutes
3. Range: Continuous Run "cont", can be interrupted by the key, "stop" (10).

-The running time can be pre-selected, with the lid opened or closed.

-To activate the setting of the running time, press the key "time" (6).

-In the display, "time" (A-3) flashes the indication: "m : s" or "h : m", depending on the previous setting.

To set the desired value, use the adjustable knob (1). After exceeding 59 min 50 sec, the indication changes automatically to, "h : m". After exceeding 99 hours 59 min, the word "cont" appears in the display, "time" (A-3). The continuous run can only be interrupted by pressing the key, "stop" (10). The time counts down, as soon as the set speed is reached.

The display will always show the remaining running time, (see Figure 18).

For all number marked text, please refer to Figure 18.

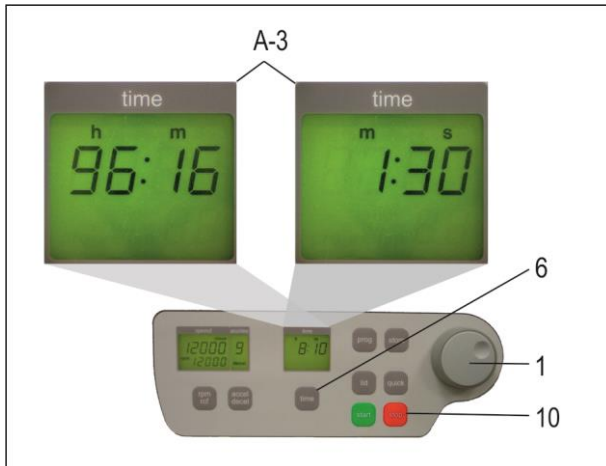

Figure 18

2.3.3 Pre-Selection of Brake Intensity and Acceleration

Selecting the key, "accel/decel" (5), this function is activated.

By pressing the key once, the word "accel" (M7) flashes, in the display "accel/decel" (A-2). The desired acceleration can be pre-selected, with the adjustable knob (1). The value 0 is equivalent to the lowest acceleration and the value 9 is equivalent to the highest acceleration.

By pressing the key "accel/decel" (5) twice, in the display "accel/decel" (A-2), indicates the word "decel" (M8). Now the desired brake intensity can be pre-selected, with the adjustable knob (1). The value 9 is equivalent to the shortest possible brake time and the value 0 to longest possible brake time.

For all number marked text, please refer to Figure 20.

See Table 4: "Acceleration and Deceleration Times", (APPENDIX P. VII). This table shows the acceleration and deceleration times, for the acceleration and deceleration stages 0 to 9, for permissible rotors.

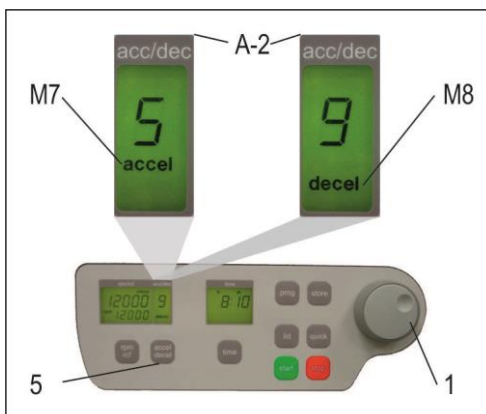

Figure 19

2.4 Radius Correction

If adapters or reducers are being used, it could change the centrifugal radius of the respective rotor. In that case, the radius can be corrected manually.

Please proceed as follows:

First close the centrifuge lid and press afterwards the key "time" (6) and the key "prog" (11) at the same time and hold down.

In the display, "time" (A-3), appears the word "radius" (M9). With the adjustable knob (1), pre-select the respective radius correction, (see Table 6, APPENDIX P. IX), in steps of 0.1cm.

As soon as the radius correction is set, the word "radius" (M9) appears. This text remains visible until the radius correction is set back to 0.

For all number marked text, please refer to Figure 20.

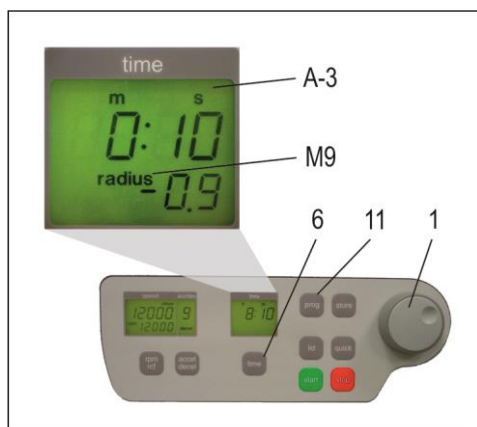

Figure 20

2.5 Program

2.5.1 Storage of Programs

The program stores up to 99 runs, with all relevant parameters, including the used rotors. Any free program number is available and can be retrieved.

Put the desired rotor into the centrifuge. By pressing the key, "prog" (11), in the display "time" (A-3) appears the word "program", (see Figure 21). With the adjustable knob (1), choose the desired program number.

If a program number is already occupied, in the display "rpm/rcf" (A-1), the words "rotor" (M3) and "22x.xx" (M4) will appear, (see Figure 21). Free program numbers will appear as 0.

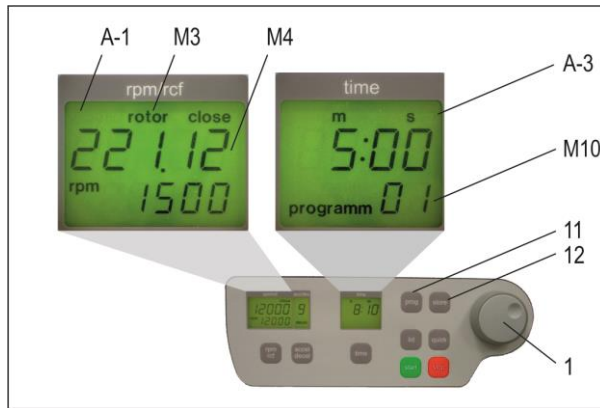

Figure 21

Close the lid of the centrifuge, now proceed as described above, to set all important run parameters. If the lid isn't closed, when storing the program in the display "rpm/rcf" (A-1), flashes alternately the word "FirSt" and "CLOSE Lid" (see Figure 22). When starting the run without storing the program, in the display "rpm/rcf" (A-1), flashes alternately the word "FirSt" and "PrESS StorE", (see Figure 23).

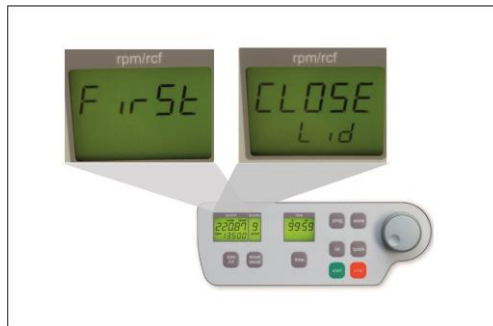

Figure 22

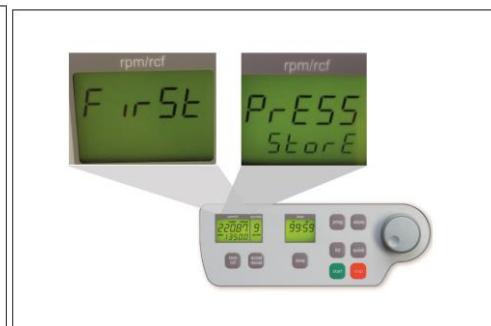

Figure 23

For alteration of data, press the key "store" (12), for approx. 1 second. If the program is stored correctly, the word "StorE" appears in the display "rpm/rcf" (A-1). As a result, the word "programm" (M10) disappears. As soon as the key "store" (12) is no longer displayed, the word "programm xx" (M10) reappears. (the xx stands for the chosen program place).

If all program numbers are occupied, take an old number that is not needed any longer and replace it with the new parameters.

2.5.2 Recall of Stored Programs

To recall stored programs, press the key "prog" (11), with the lid already closed. Inside the display "time" (A-3), appears "programm --"(M10). With the adjustable knob (1), pre-select the desired program number.

In the respective displays, the stored values, for that program, will appear.

If there is not the correct rotor inside the centrifuge, for the pre-selected program, in the display "rpm/rcf" (A-1) flashes the word "rotor" (M3). At the same time, the word "FALSE" and the stored rotor number "22x. xx"(M4) flash in sequence of one another.

For all number marked text, please refer to Figure 24.

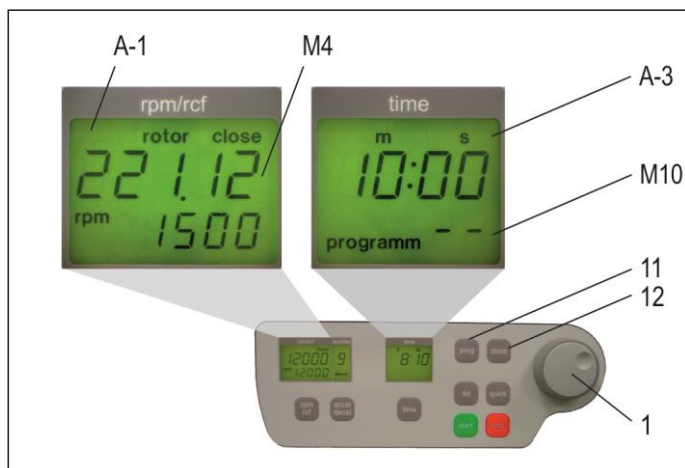

Figure 24

2.5.3 Leaving Program Mode

To leave the program mode, press the key, "prog" (11). Then, inside the display "time", appears the word "programm".

Set the display to "programm--" (M10) with the adjustable knob (1).

For all number marked text, please refer to Figure 23.

2.6 Starting and Stopping the Centrifuge

2.6.1 Starting the Centrifuge

Start the centrifuge with either the "start" key (9), or the "quick" key (8).

With the "start" key (9), stored runs or runs with manually pre-selected parameters can be started.

When the respective pre-selected running time has ended, the centrifuge will stop automatically.

With the "quick" key (8), start runs, which will last a few seconds, can be initiated.

By pressing the "quick" key (8), the centrifuge accelerates up to the pre-selected revolution.

In the display "time" (A-3), the passed running time is indicated from the moment the "quick" key (8) is pressed.

By releasing the "quick" key (8), the centrifuge stops and the running time is indicated, until the lid is opened.

For all number marked text, please refer to Figure 25.

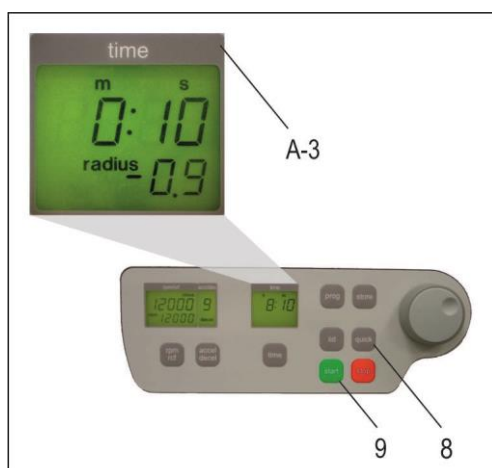

Figure 25

2.6.2 The "STOP" Key

With the "stop" key (10), the run time can be interrupted, at any time, (see Figure 26). After pressing the key, the centrifuge decelerates with the respective pre-selected intensity, down to a standstill.

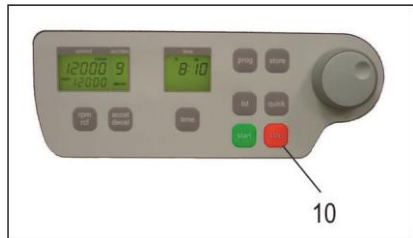

Figure 26

2.7 Imbalance Detection

In case the rotor is not equally loaded, the drive will turn off, during acceleration. The rotor decelerates to a standstill.

When in the display "time" (A-3), the word "error" (M11) along with the number "01" appears, the weight difference of the samples are too large. Weigh out the samples exactly!

Load the rotor as described in Chapters: 2.1.2 and 2.1.3.

When inside the display "time" (A-3), the word "error" along with the number "02" appear, (see Figure 27)

Potential Reason for the Error Screen: The imbalance switch is defective.

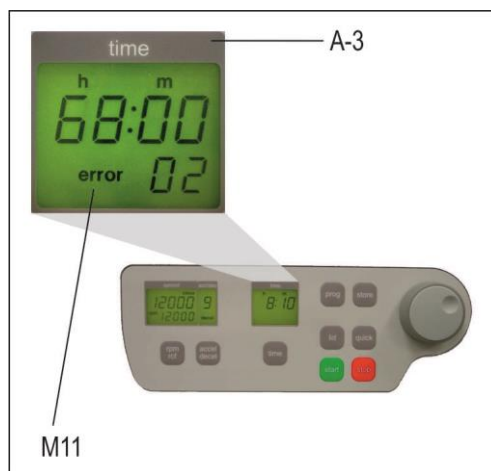

Figure 27

2.8 Timer Function

This timer function enables to program a planned ending or start of centrifugation. After closing the centrifuge lid and setting all the needed values, the timer function can be activated.

For this purpose press the bottom „time“ (6) for five seconds. This will take you to the time setting of the timer and the display "rpm/rcf" (A-1) shows the words "End in". The display „time“ (A-3) shows the remaining time until the **end** of the centrifugation. The remaining time can be set between 1 min and 99 h 59 min by pressing the bottom "time" (6) and turning the adjusting knob (1).

Alternatively to the "End in" mode, you can choose the "Start in" mode by pressing the bottom „rpm/rcf“ (4). The display „time“ (A-3) shows the remaining time until the **start** of the centrifugation.

The timer starts automatically after setting the needed value. The set time can be adjusted by pressing again the bottom "time" (6) and turning the adjusting knob (1).

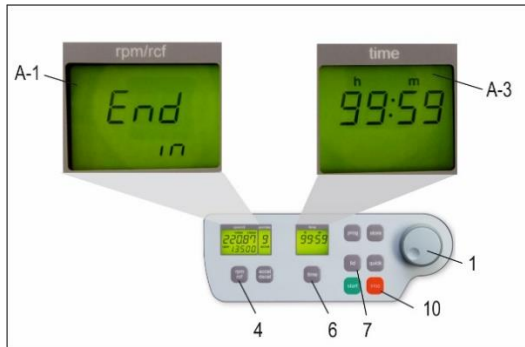

Figure 28

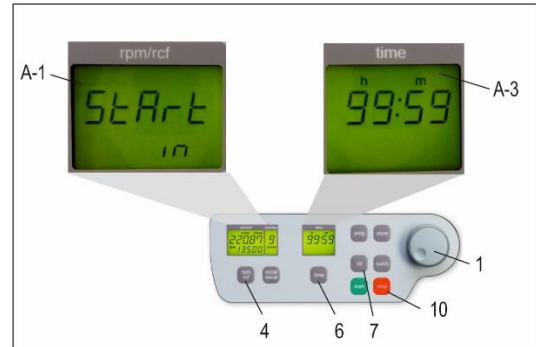

Figure 29

You can interrupt this function by pressing the bottom “stop” (10) or the bottom “lid” (11). During the timer mode, all the other bottoms have no function.

For all number marked text, please refer to Figure 28 and 29 .

3. MAINTENANCE

3.1 Maintenance and Cleaning

3.1.1 General Care:

Maintenance of the centrifuge is dependent on prolonging the life of the rotor, the rotor chamber and the rotor accessories. Please be sure to clean the accessories, especially the sealing of the aerosol-tight rotors and insert bolts, of swing out rotors. Following, lubricate the bolts or sealing, with the recommended HERMLE Rotorgrease - Order No.: 38-5656.

Please pay special attention to anodized aluminum parts. Breakage of rotors can be caused by the slightest damages.

In case of rotors, buckets or tube racks becoming in touch with corrosive substances, the affected area must be cleaned, thoroughly.

Corrosive substances, such as, must be avoided: alkalis, alkaline soap solutions, alkaline amines, concentrated acids, solutions containing heavy metals, water-free chlorinated solvents, saline solutions, e.g. salt water, phenol, halogenated hydrocarbons.



Cleaning – Units, Rotors, Accessories:

- Turn the device off and disconnect from the power supply, before beginning any cleaning or disinfecting. Do not pour liquids into the housing interior.
- Spray disinfectant on the device.
- Thorough cleaning not only has its purpose in hygiene, but also in avoiding pollution based corrosion.
- In order to avoid damaging anodized parts, such as rotors, reduction plates etc.; only pH-neutral Detergents, with a pH-value of 6-8, may be used for cleaning. Alkaline cleaning agents must not be used, (pH-value > 8).
- After cleaning, please ensure all parts are dried thoroughly, either by hand or in a hot-air cabinet (Max. Temperature + 50°C/122°F).
- It is necessary to coat anodized aluminium parts with anti-corrosion oil regularly, in order to increase their life-span and reduce corrosion predisposition.
- Due to humidity or not hermetically sealed samples, condensation may form. The condensation has to be removed from the rotor chamber, with a soft cloth regularly.



The maintenance procedure has to be repeated every 10 to 15 runs, but at least once a week!

- Connect the unit to the power supply, after the equipment is completely dry.
- Do not implement disinfection with UV-, beta- and gamma-rays or other high energy radiation.
- Metal rotors can be autoclaved.
- Rotor lid and adapters can also be autoclaved, (Max. 121°C/250°F, 20 min).
- The tube racks are made of PP and **cannot** be autoclaved, at 134°C/273°F.

3.1.2 Cleaning and Disinfecting of the Unit

1. Open the lid, before turning off the unit. Disconnect from the power supply.
2. Open the rotor nut, by turning the rotor key counter-clockwise.
3. Remove the rotor.
4. For cleaning and disinfection of the unit and the rotor chamber, use the above mentioned cleaner.
5. Clean all accessible areas of the device and its accessories, including the power cord, with a damp cloth.
6. Wash the rubber seals and rotor chamber thoroughly, with water.
7. Rub the dry rubber seals with glycerol or talc, to prevent these from becoming brittle. Other components of the unit, e.g. the lid lock, motor shaft and rotor, should **not** be greased.
8. Dry the motor shaft with a soft, dry and lint-free cloth.
9. Examine the unit and accessories for damage.

Remove adherent dust, at least every 6 months, from the ventilation slots in the centrifuge, by using a soft brush.

*Before doing so, please switch off the unit and disconnect from the power supply.

3.1.3 Cleaning and Disinfecting of the Rotor

1. Clean and disinfect: the rotors, rotor lids and adapters, with the cleaner previously mentioned above.
2. Use a bottle brush to clean and disinfect the rotor bores.
3. Rinse the rotors, rotor lid and adapter, with clear water. Particularly, the drillings of the angle rotors.
4. When drying the rotors and accessories, set on a towel. Place the angle rotors, with bores down, to dry.
5. Dry the rotor cone with a soft, dry and lint-free cloth, check for damage. Do not grease the rotor cone.

3.1.4 Disinfection of Aluminum Rotors

In case of infectious material spilling into the centrifuge, the rotor and rotor chamber have to be disinfected, promptly after the run. Rotors may be autoclaved, the recommended time for autoclaving: 15 – 20 min at 121°C/250°F, (2.15 bar).

3.1.5 Disinfection of PP-Rotors



ATTENTION Polypropylene rotors **must not** be autoclaved!

Gas Sterilization

Adapters, bottles and rotors may be gas sterilized, with Ethylenoxyd. According to the duration of the application, allow items to properly air out, after the sterilization and before usage.



ATTENTION: The temperature may rise during the sterilization; rotors, adapters and bottles should not be fully closed, keep completely unscrewed.

Chemical Sterilization

Bottles, adapters and rotors may be treated, with the usual liquid disinfectants.



ATTENTION: Before applying any other cleaning resp. decontamination method other than what was recommended by the manufacturer, contact the manufacturer to ensure that it will not damage the unit or the rotor.

3.1.6 Glass Breakage

With high g-values, the rate of glass tube breakage increases. Glass splinters have to be removed immediately from rotor, buckets, adapters and the rotor chamber itself. Fine glass splinters will scratch and therefore damage the protective surface coating of a rotor. If glass splinters remain in the rotor chamber, fine metal dust will build up, due to air circulation. This very fine, black metal dust will severely pollute the rotor chamber, the rotor, the buckets, and the samples.

If necessary, replace the adapters, tubes and accessories, to avoid further damage. Check the rotor bores regularly, for residue and damage.



ATTENTION: Please check the relevant specifications of the tubes with the manufacturer!

3.2 Lifetime of Rotors, Round and Rectangular Buckets, Accessories

Rotors and rotor lid made of aluminum or stainless steel, have a operating time of **max. 7 years** from first use.

Transparent rotor lids and caps, made of PC or PP, as well as rotors, tube racks and adapters of PP, have a maximum operating time of up to **3 years**, from first time use.

Conditions For the Operating Time:

Proper use, damage-free condition, recommended care.

For additional information on aerosol-tight rotors, lids and buckets, please see below:

The aerosol tightness of rotors, rotor lids, buckets and caps have been tested and certified by the "TÜV Nord CERT GmbH, Certification Body Consumer Products, Essen (Germany)", in accordance with Annex AA of IEC 61010-2-020. The certificates can be downloaded on our webpage, www.hermle-labortechnik.de. Aerosol-tight rotors and buckets are marked with the label, "aerosol-tight".



ATTENTION: Autoclaving, mechanical stresses and contamination, by chemicals or other aggressive solvents, can impair the aerosol-tightness of the rotors and buckets.

Check the integrity of the seals of the aerosol-tight rotor lids or caps, before each use.

-Use only aerosol-tight rotor lids or caps, if the seals are undamaged and clean.

-Replace the seals of aerosol-tight lids and caps, after 10 autoclaving cycles.

-**Never** store aerosol-tight rotors or buckets closed.

4. TROUBLE SHOOTING

4.1 Error Message: Problem / Solution

The error messages are listed to help localize possible errors faster.

The possible error referred to in this chapter may not always be the case, as they are only theoretically occurring errors and solutions.

Always keep us informed about any kind of error occurring, which is not listed in this chapter. With this information provided, we are able to improve and complete this operation manual.

Many thanks in advance for your support.

HERMLE Labortechnik GmbH

4.2 Survey of Possible Error Messages and Solutions

4.2.1 Lid Release during Power Failure (Emergency Lid Release)

In case of power failure or malfunction, the lid of the centrifuge can be opened manually, in order to protect samples.

Please proceed as follows (see Figure 30):



- **Switch off the centrifuge and unplug the power cord, wait until the rotor has come to a standstill (this may take several minutes)**
- **On the left hand side of the centrifuge housing, there is a plastic stopper. Remove this stopper and behind is a hexagon nut.**
- **Take the delivered box spanner, put it into the hole, and lock the box spanner, with the hexagon nut (see Figure 28).**
- **Turn the box spanner to the right (clockwise), up to the limit.**
ATTENTION: Only turn to the limit, don't tighten the nut.
- **Open the lid of the centrifuge.**
- **Switch the centrifuge on again, to proceed with regular function.**



Figure 30

4.2.2 Description of the Error Message System

The error message, "error" (M11), is shown in the "time" (A-3) display, (see Figure 31). For more detailed information, refer to Table 6: "Error Messages", (see Appendix P.IX).

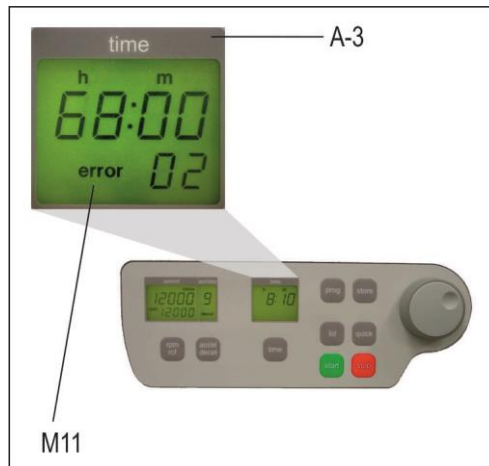

Figure 31

4.2.3 Procedure while error 14, from software version 1.76

If Error 14 occurs, there is a problem with the speed sensor. The centrifuge lid is closed for undefined period of time and in the "rpm/rcf" (A-1) display shows the lettering "USEr GuidE" (see Figure 32).

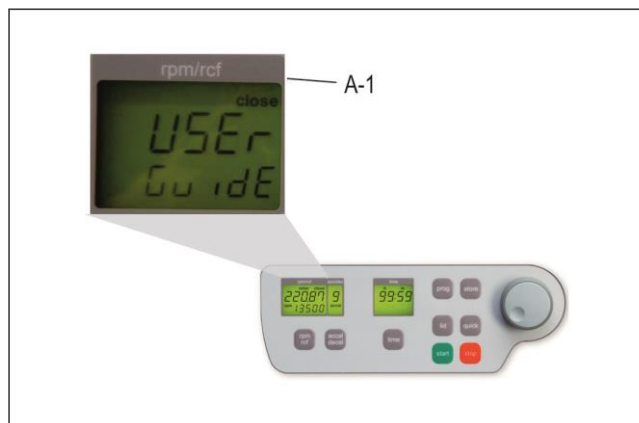

Figure 32

To reopen the centrifuge lid, switch off the device and wait until the rotor has come to a **standstill**. Take from **Table 4: Acceleration and Deceleration Times** the maximum deceleration time of the respective rotor. Level 0 corresponds to unbroken rundown, which occurs at error 14. If the centrifuge lid is opened before standstill of the rotor, a following error can occur.

Once the rotor has come to a standstill, open the centrifuge lid with the emergency release. Proceed as described in chapter 4.2.1, p 26. After opening the centrifuge lid, switch on the device again. Error 14 and the lettering "USEr GuidE" should be eliminated.

If this error occurs again, please contact the service.

4.2.4 Procedure while error 38 – Lid motor is blocked

The lid motor is blocked and for 10 seconds the error message “error 38” is shown in the display “time” (A-3). After expiring of this error message please press the key “lid” (7). If the lid lock doesn't loose, repeat this procedure two or three more times. If the lid lock still doesn't loose, the lid must be opened by using the manual emergency release. Proceed as described in chapter 4.2.1. After opening the centrifuge lid, switch on again the device. The lid lock adjusts itself in the basic position. The closing process can be carried out normally again.

5. RECEIPT OF CENTRIFUGES FOR REPAIR



Health risk from contaminated equipment, rotors and accessories

In case of returning the centrifuge for repairing, to the manufacturer, please know the following:

The centrifuge **must** be decontaminated and cleaned, before shipment, for the protection of persons, environment and material.

Decontamination certificate at goods return delivery, (see APPENDIX P. XIII)

We reserve the right to accept contaminated centrifuges.

Furthermore, all costs that may have occurred during the cleaning and disinfection of the units, will go to the debit of the customer's account.



Return of Power Cords

In case of a return of a centrifuge, we also ask you to send its power cord. This eliminates the risk of a faulty power cord. If no power cord is attached to the centrifuge, a new one will be delivered and charged.

We ask for your understanding.

6. TRANSPORT, STORAGE AND DISPOSAL

6.1 Transport

Before transporting, take out the rotor.

Only transport the unit in its' original packaging.

Use a transport aid, for transporting over longer distances, to fix the motor shaft.

	Air Temperature	Rel. Humidity	Air Pressure
General Transportation	-25 to 60 °C	10 to 75 %	30 to 106 kPa
	-13°F to 140°F		

6.2 Storage

During storage of the centrifuge, the following environmental conditions must be observed:

	Air Temperature	Rel. Humidity	Air Pressure
Transport Packaging	-25 to 55 °C	10 to 75 %	70 to 106 kPa
	-13°F to 131°F		

6.3 Disposal

Information on the disposal of electrical and electronic equipment in the European Community:

Within the European Community, disposal for electrically powered equipment is dictated by national regulations based on the EU Directive 2012/19/EC on Waste Electrical and Electronic Equipment (WEEE2).

According to this directive, all devices supplied **after** 13.08.2005 in the business-to-business sector, in which this product is classified, may no longer be disposed of with municipal waste or household waste. To document this, they are marked with the following label:



As this device is a device used exclusively for business purposes (B2B), it must not be handed into public waste disposal companies.

The device can be disposed of by stating the date of purchase and the device number at:

Hermle Labortechnik GmbH, Siemensstraße 21, 78564 Wehingen, WEEE-Reg. No. DE 55649821

For all devices delivered before 13.08.2005, the last user is responsible for proper disposal.

RoHS Declaration of Conformity

HERMLE Labortechnik GmbH, Siemensstraße 25, 78564 Wehingen, Germany, hereby declares that all components produced are in conformity with Directive 2011/65/EU of the European Parliament and of the Council of 31.03.2015 on the restriction of the use of certain hazardous substances in electrical and electronic equipment.

7. APPENDIX

Table 1: Technical Data.....	IV
Table 2: Permissible Net Weight	V
Table 3: Max. Speed and RCF-Values for Permissible Rotors	V
Table 4: Acceleration and Deceleration Times	VI
Table 5: Error Messages	VII
Table 6 (Part 1): Radius Correction.....	VIII
Table 6 (Part 2): Radius Correction.....	IX
Table 6(Part 3): Radius Correction.....	X
Table 7: Abbreviations	X
Redemption Form / Decontamination Certificate.....	XI

Table 1: Technical Data

Manufacturer		HERMLE Labortechnik GmbH, 78564 Wehingen			
Type		Z 366			
Dimensions					
Width		43 cm			
Depth		51 cm			
Height		36 cm			
Weight without rotor		52 kg			
Max. Speed		15000 min ⁻¹			
Max. Volume		6 x 250 ml			
Max. RCF		21379 x g			
Allowable Density		1,2 kg/dm ³			
Allowable Kinetic Energy		34363 Nm			
Mains Power Connection AC		230 V / 50-60 Hz 1 ph	120 V / 50-60 Hz 1 ph		
Voltage Fluctuation		± 10 %	± 10 %		
Current Consumption		2,4 A	4,2 A		
Power Consumption		530 W	520 W		
Radio Interference		IEC 61326-1			
Audit Requirement (BGR 500)		yes			
Ambient Conditions (EN/IEC 61010-1)					
- Environment		<p style="text-align: center;">For Indoor Use Only</p> <p style="text-align: center;">Use up to an altitude of 2000 m above MSL</p> <p style="text-align: center;">2°C up to 35°C</p> <p style="text-align: center;">Max. relative humidity 80 % for temperatures up to 31°C, decreasing linearly to 50 % relative humidity up to 35°C.</p>			
- High					
- Ambient Temperature					
- Max. Relative Humidity					
- Overvoltage Category (IEC 60364-4-443)					II
- Degree of Contamination					2
Class of Protection		I			
Not suitable for use in hazardous environments.					
EMV		EN / IEC	FCC Class B	EN / IEC	
Interference Emission , Noise		61326-1		61326-1	
		Category B		Category B	
Noise Level (depending on the rotor)		≤ 61 +2 dB(A)			
Write from Operator					
Inventory-No.:		_____			
Monitoring-No.:		_____			
Environment:		_____			
Maintenance Contract:		_____			
Responsible Service Office		HERMLE Labortechnik GmbH		or dealer service office	
		Siemensstraße 25			
		78564 Wehingen			
		Tel.: (49)7426 / 96 22-89			
		Fax: (49)7426 / 96 22-49			
Responsible Dealer					

Table 2: Permissible Net Weight

Rotor-Number	Max. Speed	Permissible Net Weight
221.15 V20	4500 rpm	1420 g
221.16 V20	4500 rpm	620 g
221.19 V20	4500 rpm	1020 g
221.21 V20	8000 rpm	2130 g
221.18 V21	11000 rpm	840 g
221.20 V20	12000 rpm	560 g
221.22 V21	13000 rpm	492 g
221.28 V21	12000 rpm	160 g
221.52 V20	9000 rpm	760 g
221.68 V20	15000 rpm	165 g
220.87 V22	15000 rpm	85 g
220.87 V20	15000 rpm	85 g
221.61 V20	4500 rpm	2228 g

Table 3: Max. Speed and RCF-Values for Permissible Rotors

Rotor-Number	Max. Speed	RCF-Value
221.15 V20	4500 rpm	3780 xg
221.16 V20	4500 rpm	2716 xg
221.19 V20	4500 rpm	2830 xg
221.21 V20	8000 rpm	10016 xg
221.18 V21	11000 rpm	15555 xg
221.20 V20	12000 rpm	14809 xg
221.22 V21	13000 rpm	15869 xg
221.28 V21	12000 rpm	15775 xg
221.52 V20	9000 rpm	11771 xg
221.68 V20	15000 rpm	21379 xg
220.87 V22	15000 rpm	21379 xg
220.87 V20	15000 rpm	21379 xg
221.61 V20	4500 rpm	3724 xg

Table 4: Acceleration and Deceleration Times

Rotor-Number	Acceleration Time		Deceleration Time	
	Level 0	Level 9	Level 0	Level 9
221.15 V20	309	34	458	36
221.16 V20	452	43	616	38
221.19 V20	149	25	985	20
221.21 V20	664	130	2906	92
221.18 V21	697	85	2313	70
221.20 V20	506	60	1745	49
221.22 V21	446	48	1323	49
221.28 V21	512	54	1439	47
221.52 V20	753	115	2395	72
221.68 V20	256	28	328	24
220.87 V22	251	25	610	26
220.87 V20	251	25	610	26
221.61 V20	34	311	36	387

in seconds

Acceleration Time from 0 rpm -> U_{max}	Deceleration Time from U_{max} -> 0 rpm
--	--

Table 5: Error Messages

Error-No.:	Description
1	Imbalance arose
2	Imbalance sensor is defective
4	Imbalance switch has been activated for longer than 5 seconds
8	Transponder in the rotor is defective
11	Temperature sensor is defective
12	Chamber over temperature
14 USER Guide	Leap of speed is too large between two measurements. Centrifuge lid is closed for undefined period of time
16	Standstill detection defective
33	Open lid while motor is running
34	Lid contact defective
38	Lid motor is blocked
40	Communication with frequency converter disturbed during start
41	Communication with frequency converter disturbed during stop
42	Shortcircuit in the frequency converter
43	Under-Voltage frequency converter
44	Overvoltage frequency converter
45	Over temperature frequency converter
46	Over temperature motor
47	Over current frequency converter
48	Timeout between control unit and frequency converter
49	Other error frequency converter
55	Over Speed
70	Timeout between controller and RS232 interface
99	Rotor is not allowed in this centrifuge
FALSE	Inserted rotor does not exist in the program
rotor no	Rotor is not detected

Table 6 (Part 1): Radius Correction

<i>Rotor No.</i>	<i>Adapter/Bucket Order No.</i>	<i>Radius (cm)</i>	<i>Correction (cm)</i>
Swing Out Rotor 221.15		16.7	0
	628.000	15.9	0.8
	628.001	16.1	0.6
	628.002	16.3	0.4
	628.003	16.1	0.6
	628.004	16.3	0.4
	628.005	16.4	0.3
	628.006	16.3	0.4
	628.007	16.3	0.4
	628.008	16.1	0.6
	628.010	15.5	1.2
	628.011	16.1	0.6
	628.012	16.3	0.4
	628.013	15.9	0.8
	628.014	15.9	0.8
	628.015	16.3	0.4
	628.016	15.7	1.0
Swing Out Rotor 221.16		12.0	0
	706.000	10.1	1.9
Angle Rotor 220.88		8.4/8.5	0
		8.3	0.2
		7.7	0.7
Angle Rotor 221.19		12.5	0
		10.9	
	701.011	12.2	0.3
		10.6	
	701.012	10.5	2.0
		8.9	
Angle Rotor 221.21		14.0	0
	713.015	9.7	4.3
		13.2	0.8
	713.020	10	4.0
		13.3	0.7
	713.025	10	4.0
		13	1.0
	713.028	9.9	4.1
	12.5	1.5	
	713.030	12	2.0
	713.042	11.7	2.3

Table 6 (Part 2): Radius Correction

Rotor No.	Adapter/Frame Order No.	Radius (cm)	Correction (cm)
Angle Rotor 221.18		11.5	0
	707.000	9.7	1.8
		11.1	0.4
	707.001	10.6	0.9
	707.002	10.3	1.2
	707.003	10.9	0.6
	707.004	10.6	0.9
	707.014	10.4	1.1
	707.015	10.4	1.1
Angle Rotor 221.20		9.2	0
	707.001	8.5	0.7
	707.002	8.5	0.7
	707.003	8.9	0.3
	707.004	8.5	0.7
	707.014	8.3	0.9
	707.000	7.5	1.7
		9.1	0.1
Angle Rotor 221.22		8.4	0
	708.003	7.9	0.5
	708.004	8	0.4
	708.017	7.7	0.7
	708.019	8.2	0.2
Angle Rotor 221.28		9.8	0
Angle Rotor 220.87		8.5	0
	704.004	8.2	0.3
	704.005	7.5	1.0
Angle Rotor 221.52		13	0
	708.050	12.7	0.3
	708.051	12.8	0.2
	701.011	11.4	1.6
	701.012	9.8	3.2
	701.015	8.3	4.7

Table 6(Part 3): Radius Correction

<i>Rotor No.</i>	<i>Adapter/Frame Order No.</i>	<i>Radius (cm)</i>	<i>Correktion (cm)</i>
Swing Out Rotor 221.61		16,5	
	630.000	16,5	0
	630.001	16,5	0
	630.002	15,9	0.6
	630.003	15,6	0.9
	630.004	15,6	0.9
	630.005	15,8	0.7
	628.016	15,5	1.0
Angle Rotor 221.68		8,5	0
	704.004	8,3	0.2
	704.005	7,7	0.8

Table 7: Abbreviations

Symbol / Abbreviation	Unit	Description
U (=rpm)	[min ⁻¹]	Revolutions per Minute
RZB(=rcf)	[x g]	Relative Centrifugal Force
PP	-	Polypropylene
PC	-	Polycarbonate
accel	-	Acceleration
decel	-	Deceleration
prog	-	Program

Redemption Form / Decontamination Certificate

Decontamination Certificate of Goods Returned upon Delivery

Enclose at all returns of equipment and assemblies absolutely!

The complete, full declaration about the decontamination is a prerequisite for the assumption and further processing of the return. If no corresponding explanation is enclosed, we carry out decontamination with costs at your expense.

Surname; Last Name: _____
Organization / Company: _____
Street: _____
ZIP CODE: _____ **place:** _____
Telephone: _____ **fax:** _____
E-Mail: _____

Please fill out in block capitals!

Pos.	Quantity	Decontaminated object	Serial number	Description/comment
1				
2				
3				
4				

Are the parts listed above in touch with the following substances?

Health endangering watery solutions, buffers, acids, alkalis:..... Yes No
 Potentially infectious agents: Yes No
 Organic reagents and solvent: Yes No
 Radioactive substances: α.. β.. γ.. Yes No
 Health endangering proteins: Yes No
 DNA: Yes No
 Have these substances reached the equipment/assembly? Yes No

If so, which ones: _____

Description of the measures for the decontamination of the listed parts:

I confirm the proper decontamination:
 Company/Dept . _____ Place and Date: _____
 Signature of the authorized person: _____

