

Agilent 1100 Series Micro Vacuum Degasser

Reference Manual



Agilent Technologies

© Copyright Agilent
Technologies 2000

All rights reserved.
Reproduction, adaption,
or translation without
prior written permission
is prohibited, except as
allowed under the
copyright laws.

Part No. G1379-90000

Edition 06/00

Printed in Germany

Warranty

The information
contained in this
document is subject to
change without notice.

*Agilent Technologies
makes no warranty of
any kind with regard to
this material,
including, but not
limited to, the implied
warranties or
merchantability and
fitness for a particular
purpose.*

Agilent Technologies
shall not be liable for
errors contained herein
or for incidental or
consequential damages
in connection with the
furnishing, performance,
or use of this material.

WARNING

For details of safety,
see Safety Information
on page 85.

Warning Symbols Used In This Book



The apparatus is marked
with this symbol when
the user should refer to
the instruction manual
in order to prevent risk
of harm to the operator
and to protect the
apparatus against
damage.

Reference Manual

In This Book

This manual contains technical reference information about the Agilent 1100 Series micro vacuum degasser. The manual describes the following:

- installation,
- optimizing performance,
- troubleshooting,
- repairing,
- parts and materials,
- theory of operation, and
- specifications.

1 Installing the Micro Vacuum Degasser

- How to install the micro vacuum degasser* 9
- Site Requirements 10
- Unpacking the Micro Vacuum Degasser 12
- Optimizing the Stack Configuration 14
- Installing the Micro Vacuum Degasser 16
- Flow Connections to the Micro Vacuum Degasser 18
- Transporting the Micro Vacuum Degasser 21

2 Optimizing Performance

- How to optimize the micro vacuum degasser to achieve best chromatographic results* 23
- Introduction to the Micro Vacuum Degasser 24
- When to Use a Micro Vacuum Degasser? 25
- Operation Modes of the Micro Vacuum Degasser 26
- Operational Hints for the Micro Vacuum Degasser 29
- Solvent Information 31
- Prevent Blocking of Solvent Filters 32

3 Troubleshooting

- Errors, their probable cause, and the action required to correct them* 33

Status Indicators 34

- Power Supply Lamp 35
- Instrument Status Indicator 35

Hardware Symptoms 36

All Lamps are Off 37

If the Status Indicator is Red 39

If the Status Indicator is Yellow and the Vacuum Pump is not Running 40

If the Status Lamp is Yellow and the Vacuum Pump Runs Continuously 41

4 Repairing the Micro Vacuum Degasser

Instructions on how to repair the micro vacuum degasser 45

Cleaning the Instrument 48

Using the ESD Strap 49

Removing and Refitting the Top Cover 50

Assembling the Main Cover 52

Exchanging the Status Light Pipe 53

Overview of Internal Parts 54

Exchanging a Vacuum Chamber 55

Exchanging the Vacuum Pump 57

Exchanging the Solenoid Valve 59

Exchanging the Degasser Control Assembly and the Sensor Assembly 60

5 Parts and Materials

Detailed illustrations and listings for parts and materials identification 63

Micro Vacuum Degasser Parts 64

Contents

| | |
|------------------------------|----|
| Cover Parts | 66 |
| Sheet Metal Kit | 67 |
| Power and Status Light Pipes | 68 |
| Accessory Kit | 69 |

Cable Overview 70

| | |
|-----------------|----|
| Remote Cables | 71 |
| Auxiliary Cable | 72 |

6 Theory of Operation

| | |
|--|----|
| <i>The vacuum degasser's operation and electronics</i> | 73 |
| How the Electronics Work | 74 |

7 Specifications

| | |
|--|----|
| <i>Performance specifications of the micro vacuum degasser</i> | 79 |
| Performance Specifications | 80 |

Legal, Safety and Warranty Information 81

| | |
|---|----|
| <i>Warranty Statement</i> | 82 |
| <i>Safety Information</i> | 85 |
| <i>Radio Interference</i> | 88 |
| <i>Sound Emission</i> | 88 |
| <i>Agilent Technologies on Internet</i> | 89 |

Contents

Installing the Micro Vacuum Degasser

How to install the micro vacuum degasser

Site Requirements

A suitable environment is important to ensure optimum performance of the micro vacuum degasser.

Power Considerations

The micro vacuum degasser power supply has wide-ranging capability (see Table 1). It accepts any line voltage in the range mentioned below. Consequently there is no voltage selector in the rear of the micro vacuum degasser. There are two externally accessible fuses, that protect the power supply.

WARNING

Shock hazard or damage of your instrumentation can result, if the devices are connected to a line voltage higher than specified.

WARNING

Never use cables other than the ones supplied by Agilent Technologies to ensure proper functionality and compliance with safety or EMC regulations.

Power Cords

Different power cords are offered as options with the micro vacuum degasser. The female end of each of the power cords is identical. It plugs into the power-input socket at the rear of the micro vacuum degasser. The male end of each of the power cords is different and designed to match the wall socket of a particular country or region.

WARNING

Never operate your instrumentation from a power outlet that has no ground connection. Never use a power cord other than the power cord designed for your region.

Bench Space

The micro vacuum degasser dimensions and weight (see Table 1) allow to place the micro vacuum degasser on almost any desk or laboratory bench. It needs an additional 2.5 cm (1.0 inches) of space at either side and approximately 8 cm (3.1 inches) at the rear for the circulation of air and electric connections.

Site Requirements

If the bench should carry a complete Agilent 1100 Series system, make sure that the bench is designed to carry the weight of all the modules.

Environment

Your micro vacuum degasser will work within specifications at ambient temperatures and relative humidity as described in Table 1.

CAUTION

Do not store, ship or use your micro vacuum degasser under conditions where temperature fluctuations could cause condensation within the micro vacuum degasser. Condensation will damage the system electronics. If your micro vacuum degasser was shipped in cold weather, leave it in its box and allow it to warm slowly to room temperature to avoid condensation.

Table 1 Physical Specifications

| Type | Specification | Comments |
|-------------------------------------|--|----------------------------|
| Weight | 7 kg (15.4 lbs) | |
| Dimensions (width × depth × height) | 345 × 435 × 80 mm (13.5 × 17 × 3.1 inches) | |
| Line Voltage | 100 – 120 or 220 – 240 VAC, ± 10 % | Wide-ranging capability |
| Line Frequency | 50 or 60 Hz, ± 5 % | |
| Power consumption | 30 W | Maximum |
| Ambient Operating Temperature | 0 – 55 °C (32 – 131 °F) | see CAUTION on page 11 |
| Ambient Non-operating Temperature | -40 – 70 °C (-4 – 158 °F) | |
| Humidity | < 95 %, at 25 – 40 °C (77 – 104 °F) | Non-condensing |
| Operating Altitude | Up to 2000 m (6500 ft) | |
| Non-operating Altitude | Up to 4600 m (14950 ft) | For storing the instrument |
| Safety Standards: IEC, CSA, UL | Installation Category II, Pollution Degree 2 | |

NOTE

The Agilent 1100 Series vacuum degasser has been tested for evaporation of solvents into the atmosphere by an independent institute with approved methods. The tests were performed with Methanol (BIA Nr. 7810) and Acetonitrile (NIOSH, Nr. 1606). Evaporation of these solvents into the atmosphere when operating the degasser was below the limits of detection.

Unpacking the Micro Vacuum Degasser

Damaged Packaging

Upon receipt of your micro vacuum degasser, inspect the shipping containers for any signs of damage. If the containers or cushioning material are damaged, save them until the contents have been checked for completeness and the micro vacuum degasser has been mechanically and electrically checked. If the shipping container or cushioning material is damaged, notify the carrier and save the shipping material for the carriers inspection.

CAUTION

If there are signs of damage, please do not attempt to install the micro vacuum degasser.

Delivery Checklist

Ensure all parts and materials have been delivered with the micro vacuum degasser. The delivery checklist is shown below. To aid in parts identification, please see Chapter 5 “Parts and Materials”. Please report missing or damaged parts to your local Agilent Technologies Sales and Service Office.

Table 2

Vacuum Degasser Delivery Checklist

| Description | Quantity |
|-------------------------|-----------------|
| Vacuum Degasser | 1 |
| Power Cable | 1 |
| Remote Cable | 1 |
| Auxiliary Cable | As ordered |
| Reference Manual | 1 |
| Accessory Kit (Table 3) | 1 |

Accessory Kit Contents

Table 3

Accessory Kit Contents G1322-68705

| Description | Part Number | Quantity |
|---------------------------------|--------------------|-----------------|
| Syringe* | 5062-8534 | 1 |
| Syringe Adapter | 9301-1337 | 1 |
| Mounting Tool | 0100-1710 | 1 |
| Waste Tube** | 5062-2463 | 1 |
| Connecting Tubes labeled A to D | G1322-67300 | 4 |

* Reorder Number (pack of 10)

** Reorder Number (5m)

Optimizing the Stack Configuration

If your micro vacuum degasser is part of a system, you can ensure optimum performance by limiting the configuration of the system stack to the following configuration. This configuration optimizes the system flow path, ensuring minimum delay volume (from point of solvent mixing to head of column) and dead volume (from point of injection to detector outlet).

Figure 1 Recommended Stack Configuration (Front View)

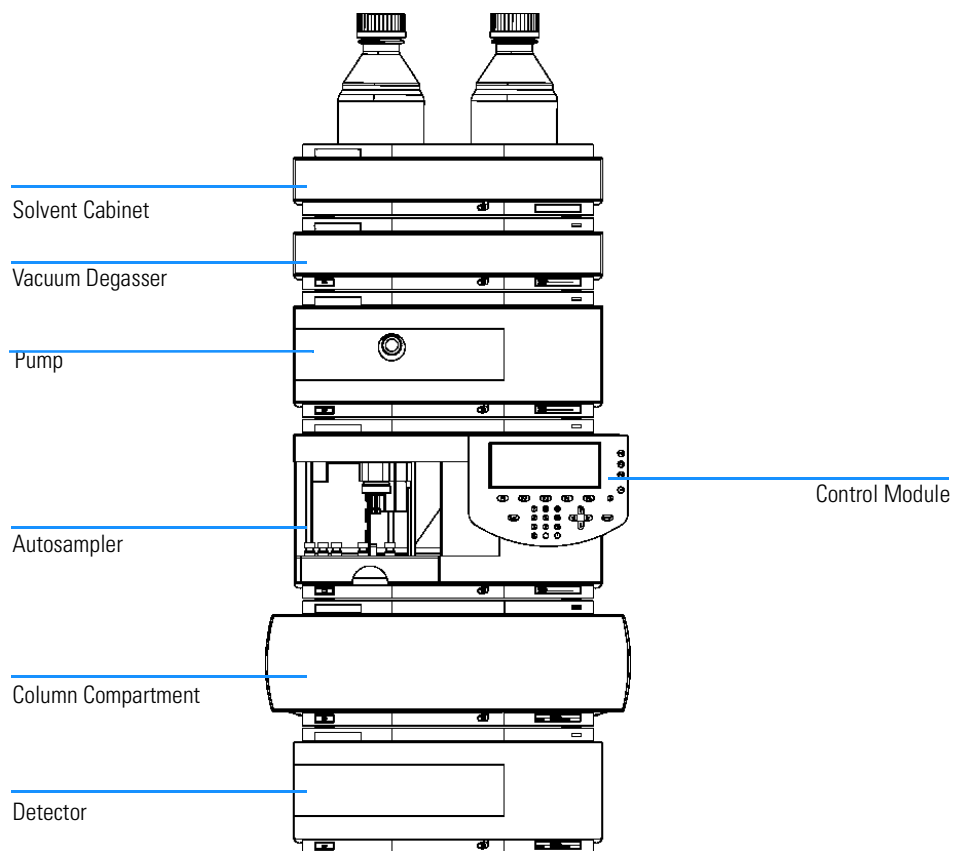
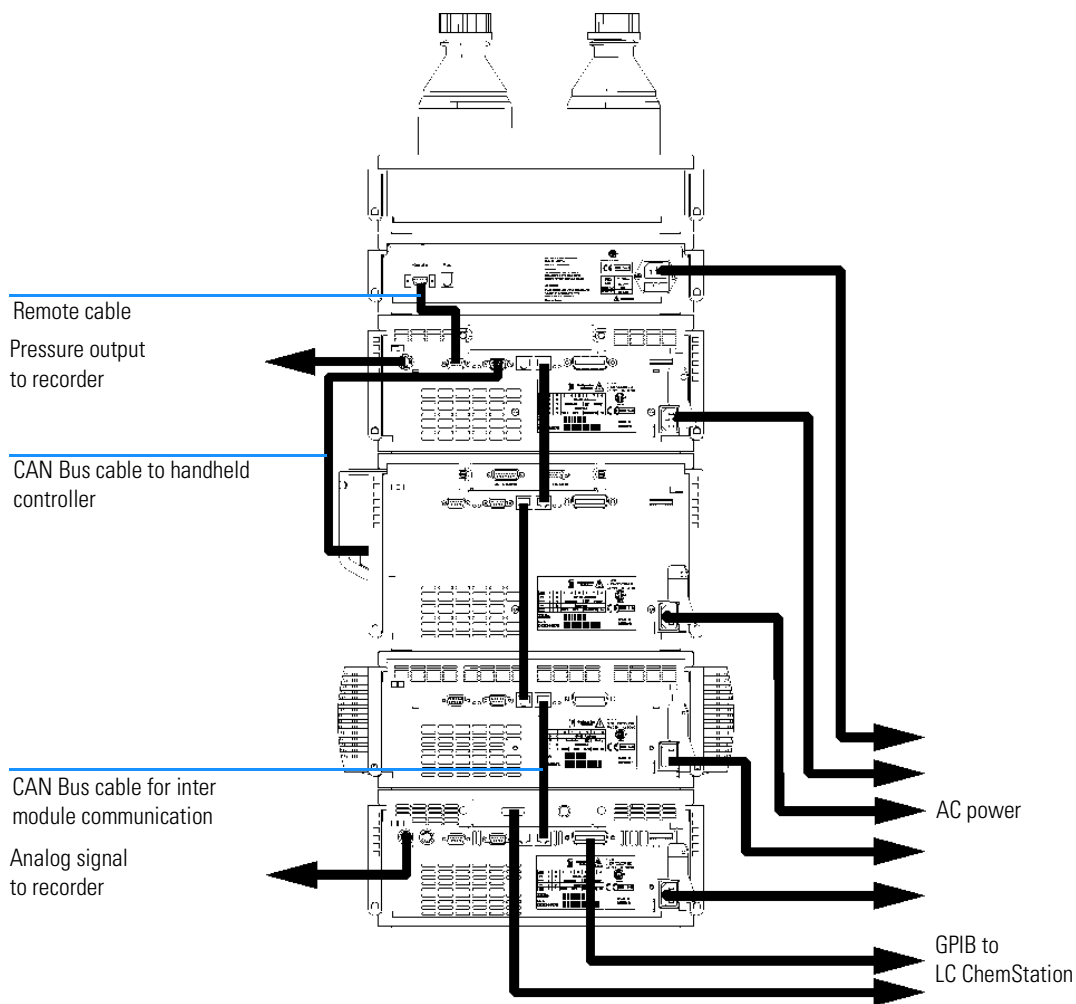

Figure 2 Recommended Stack Configuration (Rear View)



Installing the Micro Vacuum Degasser

Parts required Micro Vacuum degasser
Power cable
Interface cable as ordered, see “Cable Overview” on page 70

Preparation Locate bench space
Provide power connections
Unpack the vacuum degasser module

- 1 Place the micro vacuum degasser on the bench.
- 2 Ensure the power switch on the front of the micro vacuum degasser is OFF (switch stands out).
- 3 Connect the power cable to the power connector at the rear of the micro vacuum degasser.
- 4 Connect the interface cable to the micro vacuum degasser. The interface cable (remote cable) is a one way connection to send a not-ready signal from the degasser to the other modules to shut down the whole system after an error condition of the degasser.

NOTE

In an Agilent 1100 Series system, the individual modules are connected through a CAN cable. The Agilent 1100 Series micro vacuum degasser is an exception. The micro vacuum degasser can be connected via the APG remote connector to the other modules of the stack. The AUX output allows to monitor the vacuum pressure in the degasser chamber. An Agilent 1100 Series control module can be connected to the CAN bus at any of the modules in the system except for the degasser. The Agilent ChemStation can be connected to the system through one GPIB cable at any of the modules (except for the degasser), preferably at the detector. For more information about connecting the control module or Agilent ChemStation refer to the respective user manual.

Installing the Micro Vacuum Degasser
Installing the Micro Vacuum Degasser

Figure 3 **Rear of the Micro Vacuum Degasser**

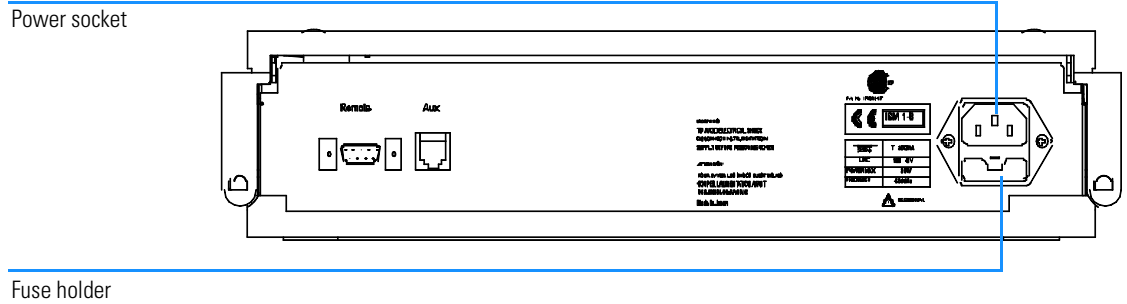
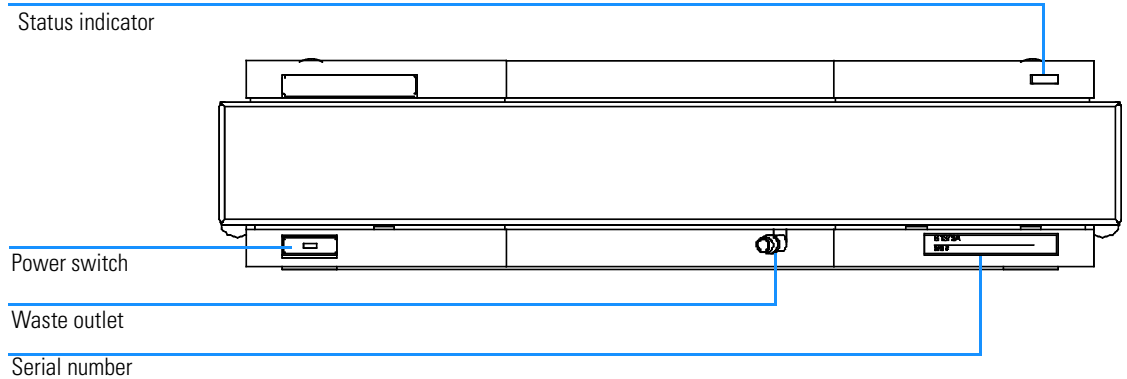

Figure 4 **Front of the Micro Vacuum Degasser**



- 5** Press in the power switch to turn on the micro vacuum degasser.

NOTE The power switch stays pressed in and a green indicator lamp in the power switch is on when the micro vacuum degasser is turned on. When the line power switch stands out and the green light is off, the micro vacuum degasser is turned off.

Flow Connections to the Micro Vacuum Degasser

| | |
|-----------------------|---|
| Parts required | Solvent cabinet including solvent bottles (filled with solvent) and bottle head assemblies Micro Vacuum degasser Solvent outlet tubes Syringe with adapter |
|-----------------------|---|

| | |
|--------------------|-----------------------------------|
| Preparation | Install the micro vacuum degasser |
|--------------------|-----------------------------------|

- 1 Place solvent cabinet with the bottle(s) on top of the micro vacuum degasser.
- 2 Remove the front cover by pressing the snap fasteners on both sides.

Figure 5

Removing the Front Cover

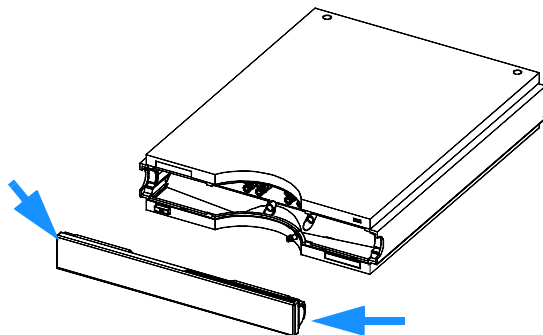

- 3 If the micro vacuum degasser is not used with an Agilent 1100 Series pump, connect the waste tube from the accessory kit to the waste outlet and place into your waste system.
- 4 Put the bottle head assemblies into solvent bottles containing your mobile phase.

WARNING

When working on capillary or tube fittings solvents may leak out. Please observe appropriate safety procedures (for example, goggles, safety gloves and protective clothing) as described in the material handling and safety data sheet supplied by the solvent vendor, especially when toxic or hazardous solvents are used.

Flow Connections to the Micro Vacuum Degasser

- 5 Connect the solvent tubes from the bottle head assemblies to the inlet connectors A through D (typically the upper connection of the channel) of the micro vacuum degasser. Use the mounting tool shown in Figure 6 to fix the tube screw. Fix the tubes in the clips of the micro vacuum degasser.

Figure 6

Mounting Tool

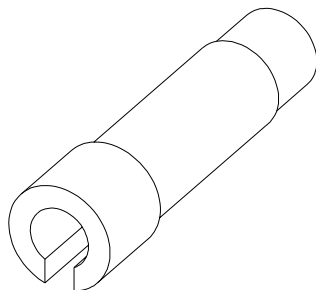

- 6 Connect the outlet tubes to the output ports (typically under connection of the channel) of the micro vacuum degasser. Use the mounting tool shown in Figure 6 to fix the tube screw.
- 7 Prime the degasser before first use (see “Priming the Degasser” on page 29).

NOTE

Atmospheric gases can diffuse through the tubing and dissolve in the mobile phase solvents. For best chromatographic results, keep the length of tubing between the micro vacuum degasser and your pump as short as possible.

Installing the Micro Vacuum Degasser
Flow Connections to the Micro Vacuum Degasser

Figure 7 Flow Connections to the Micro Vacuum Degasser

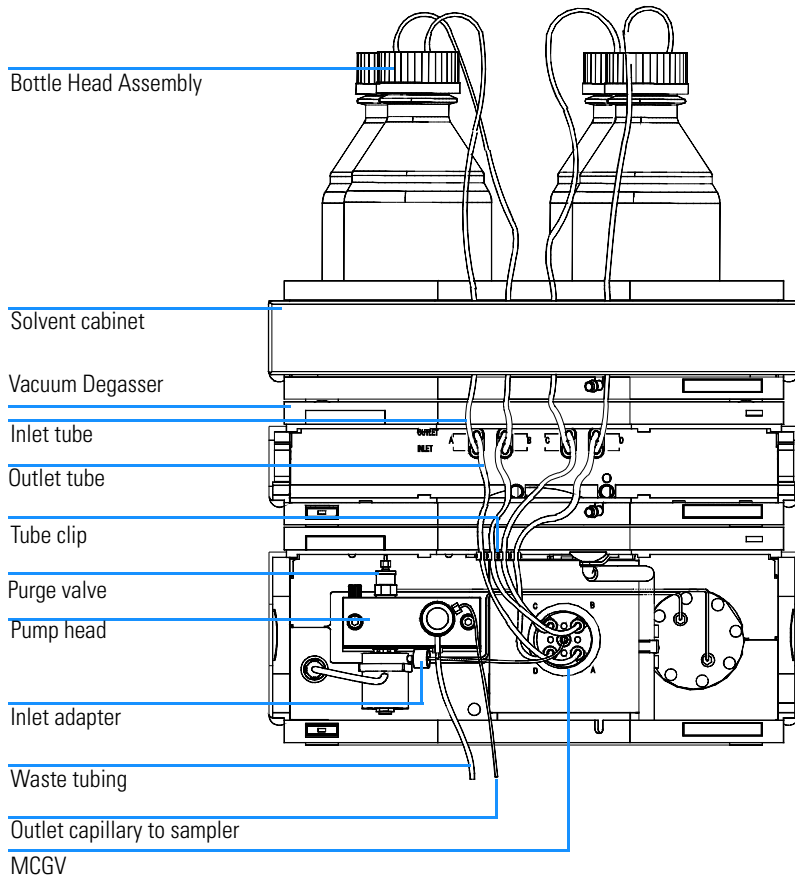

Transporting the Micro Vacuum Degasser

WARNING

Drain any remaining solvents from the degassing channels before transporting the micro vacuum degasser.

- 1 Disconnect the solvent tubes from solvent inlets from front panel.
- 2 Disconnect one of the solvent tubes from your pump.
- 3 Connect syringe adapter to solvent tube of this solvent channel.
- 4 Push syringe adapter onto syringe.
- 5 Pull syringe plunger to draw solvent out of micro vacuum degasser and tubing. Continue to draw solvent into syringe until the solvent channel is completely empty.
- 6 Repeat step 2 through step 5 for the remaining solvent channels.

Installing the Micro Vacuum Degasser
Transporting the Micro Vacuum Degasser

Optimizing Performance

How to optimize the micro vacuum degasser to achieve best chromatographic results

Introduction to the Micro Vacuum Degasser

The micro vacuum degasser comprises a 4-channel vacuum container, including 4 micro structured membranes, and a vacuum pump. When the micro vacuum degasser is switched on, the control circuit turns on the vacuum pump which generates a partial vacuum in the vacuum container. The pressure is measured by a pressure sensor. The micro vacuum degasser maintains the partial vacuum by turning on and off the vacuum pump depending on the signal from the pressure sensor.

The LC pump draws the solvents from their bottles through the special tubular plastic membranes of the vacuum container. As the solvents pass through the vacuum tubes any dissolved gas in the solvents permeates through the membranes into the vacuum container. The solvents will be almost completely degassed when leaving the outlets of the micro vacuum degasser.

Figure 8

Overview (only one of the four solvent channels is shown)

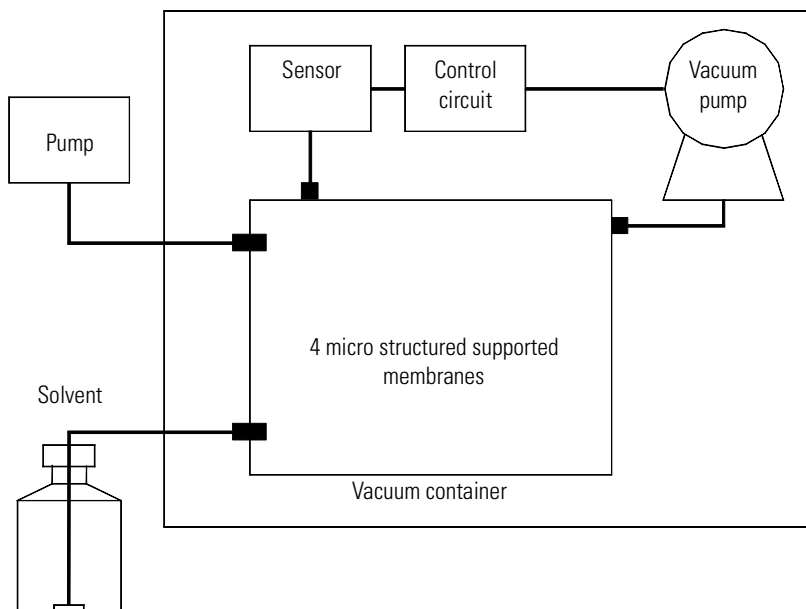

When to Use a Micro Vacuum Degasser?

For capillary LC application with our 1100 Series Capillary LC System

For high-pressure mixing pumps with low flow rates or when you have following conditions:

- if your detector is used with maximum sensitivity in the low UV wavelength range,
- if your application requires optimum injection precision
- if your application requires highest retention time reproducibility (mandatory at flow rates below 0.5 ml/min)
- if your sample or detection is sensitive to dissolved oxygen in the mobile phase (degradation).
- With a Fluorescence Detector.

Generally a degasser should be used when negative effects due to dissolved gas in the mobile phase exceed the limits that are acceptable for the user.

Negative effects that can be caused by dissolved gas are:

- Unstable flow due to unstable pumping conditions. This may result in a high ripple or high standard deviations of peak retention times and peak areas especially at low flow rates.
- Baseline noise on detectors that are sensitive to changes in the refractive index.
- Sample degradation.
- Fluorescence Quenching due to dissolved oxygen.
- Baseline drift in electrochemical detectors due to dissolved oxygen especially in reduction mode.

Operation Modes of the Micro Vacuum Degasser

The micro vacuum degasser allows various operation modes. Operation mode 1 and 2 are the normal operation modes of the degasser:

- In operation mode 1 the vacuum degasser works at 115 Torr.
- In operation mode 2 the vacuum degasser works in the range between 115 to 190 Torr.
- The continuous mode can be selected for highest degassing efficiency of the degasser. In this mode the vacuum level is below 115 Torr.
- The error mode is activated in case the degasser cannot achieve a vacuum level of 190 Torr.

(1 Torr = 1.33×10^{-3} bar)

Table 4 **Operation Modes of the Vacuum Degasser**

| | Operation Mode 1 | Operation Mode 2 | Continuous Mode | Error Mode |
|---|--|---|---|--|
| Pressure Range [Torr] | 115 | 115 -190 | Below 115 | Above 190 |
| DC Voltage Readings [mV] (rough values) | Lower Limit: 590 - 600 Upper Limit: 600 - 610 | 600 - 800 | Below 600 | Above 800 |
| Operation mode | Pump switched on and off at upper and lower limit during operation | Pump switched on every 2 minutes for 30 seconds | Pump permanently running | 8 Minutes of continuous pumping before shutdown |
| Status Indicator | OFF - below 800 mV YELLOW - above 800 mV | OFF - below 800 mV YELLOW - above 800 mV | OFF - below 800 mV YELLOW - above 800 mV | YELLOW |
| Failure Actions | Switch to Operation Mode 2 | Switch to Error Mode | Switch to Error Mode | Shut down module, switch status indicator to RED |

NOTE

The voltage readings given for the various modes are approximate values. All values are set in the factory according to the vacuum level. Depending on the vacuum sensor batch variations this will result in different voltage readings. Regardless of the readings of the various stages no adjustment should be performed on the degasser electronics.

NOTE

See “Preparing to Measure the Pressure Sensor Readings” on page 41 for setting up test meter connections to the degasser for reading the pressure sensor output.

Normal Operation Mode 1

When the degasser is turned on, the vacuum pump runs and is connected to ambient through the solenoid valve. The solenoid valve activates about 15 seconds after turning on the degasser (you can hear it click). The vacuum pump then begins to pull a vacuum on the vacuum chamber. The voltage measurements begin to decrease rapidly.

The yellow status LED turns off when the vacuum level reaches 190 Torr (DC voltage readings around 800 mV).

The normal operation mode vacuum level (115 Torr) is achieved when the DC voltage measures approximately 590 to 600 mV.

After achieving the normal operation mode vacuum level, the solenoid valve turns off. The vacuum pump continues to run for a few seconds, then it turns off.

When the DC voltage measurement rises back to approximately 600 to 610 mV, the turn on process begins again.

If the vacuum level of normal operation mode one cannot be achieved within 8 minutes the instrument turns into normal operation mode 2.

Normal Operation Mode 2 (Timing Mode)

Under certain operational conditions (large amount of dissolved gas in mobile phase, high flow rates) the 115 Torr trigger level for operation mode 1 cannot be reached. The vacuum degasser automatically turns into operation mode 2.

Normal operation mode 2 is a fixed timing mode. Every 2 minutes the degasser is turned on for 30 seconds. This assures a pressure level in the range from 115 to 190 Torr. The pressure signal measured with the auxiliary cable is in the range between 600 to 800 mV.

If the vacuum level of normal operation mode two cannot be achieved within 8 minutes the instrument turns into error mode.

Continuous Mode

The continuous mode is activated either by switching SW1 on the main board to 1 (removal of cover is required, see “Removing and Refitting the Top Cover” on page 50, for identifying SW1, see “Overview of Internal Parts” on page 54), or by connecting pin 1 (white cable) and pin 3 (green cable) of the auxiliary cable to each other.

When turning on the vacuum degasser the vacuum pump will run continuously. This will establish a vacuum level that is below the trigger level (600 mV / 115 Torr) of the normal operation mode 1.

If the vacuum level of normal operation mode 2 cannot be achieved within 8 minutes the instrument turns into error mode.

NOTE

When set to continuous mode the life time of the vacuum pump will be significantly reduced.

When to use Continuous Mode

In continuous mode the vacuum pump runs continuously thus generating the highest degassing efficiency of the degasser. This mode is recommended for very sensitive applications, which shows baseline disturbance due to ON/OFF switching of the degasser.

Error Mode

The error level for the vacuum degasser is 190 Torr (approximately 800 mV). This level cannot be achieved when there is a failure in the degasser (for example, leaks, etc.). When the error level is exceeded the yellow status indicator lamp is turned on and the vacuum pump runs continuously. If the degasser cannot reach one of the normal operation modes within 8 minutes the status indicator turns red and the vacuum pump is turned off.

Operational Hints for the Micro Vacuum Degasser

Priming the Degasser

The micro vacuum degasser can be primed either by drawing solvent through the degasser with a syringe or by pumping with the connected pump.

Priming the micro vacuum degasser with a syringe is recommended, when:

- micro vacuum degasser is used for the first time, or vacuum tubes are empty, or
- changing to solvents that are immiscible with the solvent currently in the vacuum tubes.

Priming the micro vacuum degasser by using the pump is recommended, when:

- pumping system was turned off for a length of time (for example, overnight) and if volatile solvent mixtures are used, or
- if solvents have been changed.

WARNING

When opening capillary or tube fittings solvents may leak out. Please observe appropriate safety procedures (for example, goggles, safety gloves and protective clothing) as described in the material handling and safety data sheet supplied by the solvent vendor, especially when toxic or hazardous solvents are used.

Priming with a Syringe

Before using a new degasser or new tubings for the first time:

- 1 Prime all tubings with at least 5 ml of iso-propanol no matter whether the channels will be used with organic mobile phase or with water.

If you are changing to a solvent that is immiscible with the solvent currently in the tubing continue as follows:

- 2 Replace the current solvent with iso-propanol, if current solvent is organic or with water, if current solvent is an inorganic buffer or contains salt.

- 3 Disconnect solvent outlet tube of the channel that is supposed to be primed from your pump.
- 4 Connect syringe adapter to solvent outlet tube.
- 5 Push syringe adapter onto syringe.
- 6 Pull syringe plunger to draw at least 5 ml of solvent through degasser and tubing.
- 7 Replace the priming solvent with the new solvent of your choice.
- 8 Pull syringe plunger to draw at least 5 ml of solvent through degasser and tubing.
- 9 Disconnect syringe adapter from solvent tube.
- 10 Connect solvent tube to your pump.
- 11 Repeat step 3 to step 10 for the other solvent channels.

NOTE

When priming the micro vacuum degasser with a syringe the solvent is drawn through the degasser tubes very quickly. The solvent at the degasser outlet will therefore not be fully degassed. Pump for approximately 5 minutes with your selected flow rate before starting any application. This will allow the micro vacuum degasser to properly degas the solvent in the degasser tubes.

NOTE

The pump should never be used for priming empty tubings (never let the pump run dry). Use the syringe to draw enough solvent for completely filling the tubings to the pump inlet before continuing to prime with the pump.

Priming with the Pump

When the pumping system has been turned off for a certain time (for example, overnight) oxygen will rediffuse into the solvent channels between the micro vacuum degasser and the pump. Solvents containing volatile ingredients will slightly lose these, if left in the degasser without flow for a prolonged period of time. Therefore priming of the micro vacuum degasser and the pumping system is required before starting an application.

- 1 Flush the micro vacuum degasser and all tubes with at least 5 ml of solvent.
- 2 Repeat step 3 through step 10 with other channels, where needed.

Solvent Information

Always filter solvents through 0.4 μm filters, small particles can permanently block the capillaries. Avoid the use of the following steel-corrosive solvents:

- Solutions of alkali halides and their respective acids (for example, lithium iodide, potassium chloride, and so on).
- High concentrations of inorganic acids like sulfuric acid, especially at higher temperatures (replace, if your chromatography method allows, by phosphoric acid or phosphate buffer which are less corrosive against stainless steel).
- Halogenated solvents or mixtures which form radicals and/or acids, for example:

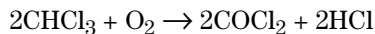

This reaction, in which stainless steel probably acts as a catalyst, occurs quickly with dried chloroform if the drying process removes the stabilizing alcohol.

- Chromatographic grade ethers, which can contain peroxides (for example, THF, dioxane, di-isopropylether) such ethers should be filtered through dry aluminium oxide which adsorbs the peroxides.
- Mixtures of carbon tetrachloride with 2-propanol or THF dissolve stainless steel.

Prevent Blocking of Solvent Filters

Contaminated solvents or algae growth in the solvent bottle will reduce the lifetime of the solvent filter and will influence the performance of the pump. This is especially true for aqueous solvents or phosphate buffers (pH 4 to 7). The following suggestions will prolong lifetime of the solvent filter and will maintain the performance of the pump.

- Use sterile, if possible amber solvent bottles to slow down algae growth.
- Filter solvents through filters or membranes that remove algae.
- Exchange solvents every two days or refilter.
- If the application permits add 0.0001–0.001 M sodium azide to the solvent.
- Place a layer of argon on top of your solvent.
- Avoid exposure of the solvent bottles to direct sunlight.

Checking the Solvent Filters

The solvent filters are on the low-pressure side of the pumping system. A blocked filter therefore does not affect the pressure readings of the pump. The pressure readings cannot be used to identify blocked filters. If the solvent cabinet is placed on top of the micro vacuum degasser the filter condition can be checked in the following way:

Remove the tubing at the inlet port of the micro vacuum degasser. If the filter is in good condition the solvent will freely drip out of the solvent tube (due to hydrostatic pressure). If the solvent filter is partly blocked no solvent or only very little solvent will drip out of the solvent tube.

Cleaning the Solvent Filters

- Remove the blocked solvent filter from the bottle-head assembly and place it in a beaker with concentrated nitric acid (35%) for one hour.
- Thoroughly flush the filter with bidistilled water (remove all nitric acid).
- Replace the filter.

NOTE

Never use the system without solvent filter installed.

Troubleshooting

Errors, their probable cause, and the action required to correct them

Status Indicators

Two status lamps are located on the front of the micro vacuum degasser. The left lamp indicates the power supply status, the right lamp indicates the micro vacuum degasser status.

Figure 9 **Location of Status Lamps**

Status indicator

Power supply lamp

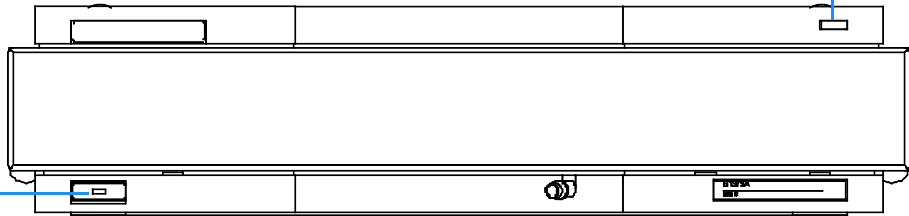

Power Supply Lamp

The power supply lamp is integrated into the main power switch. When the lamp is illuminated (green), the power is ON.

Instrument Status Indicator

The instrument status indicator indicates one of three possible instrument conditions.

- When the lamp is OFF, the micro vacuum degasser is in *ready* condition (only if the power supply lamp is ON, otherwise, the instrument is switched off, or there is a defect in the power supply). A ready condition exists when there is sufficient vacuum in the micro vacuum degasser.
- A *busy* condition is indicated, when the lamp is yellow. A busy condition exists when the vacuum pump of the micro vacuum degasser is working to generate or maintain vacuum in the chambers. This is the case when the micro vacuum degasser is turned on for the first time or the pressure rises above its limit during normal operation.
- An *error* condition is indicated, when the lamp is red. An error condition exists when the micro vacuum degasser detects an internal defect that does not allow the vacuum to be built up in a certain time frame (approximately 8 minutes).

CAUTION

If the error LED is on, there is either an internal leak in the vacuum system or an electronic failure. In case of an internal leak it is possible that solvent may enter the vacuum chamber and solvent may leak into the waste drain. To prevent any damage of the micro vacuum degasser, switch off the micro vacuum degasser and remove the solvent bottles from the solvent cabinet to stop any gravity-caused flow of solvent into the vacuum chamber.

Hardware Symptoms

In case of a problem with the vacuum system or the electronic control the micro vacuum degasser status lamp will be red. The micro vacuum degasser will generate an error output on the remote lines. This will shut down other system modules when connected via remote cable, see “Installing the Micro Vacuum Degasser” on page 16. The micro vacuum degasser itself will not be able to generate any error messages in the system logbook of the Agilent 1100 Series.

The following pages describe hardware symptoms which help you to isolate the cause of a hardware failure.

All Lamps are Off

If all other modules in the system are on (power switch lamp is green) and are recognized by the connected user interface (module parameters can be set, module-specific screens appear, and so on), then do the following to determine the problem with the micro vacuum degasser:

- ❑ Ensure the power cable is connected to the degasser, and the power cable is connected to line power.
- ❑ Ensure the power switch on the front of the module is ON.
- ❑ Ensure the power fuses are OK.

The fuse holders are located on the rear panel of the micro vacuum degasser and are part of the power socket. Check the fuses, and change if necessary:

- 1 Switch off the power switch at the front of the instrument.
- 2 Remove the power cable from the power connector at the rear of the instrument.
- 3 Press down the clip of the fuse holder and pull out of the power socket.

Figure 10

Fuse Holder and Clip

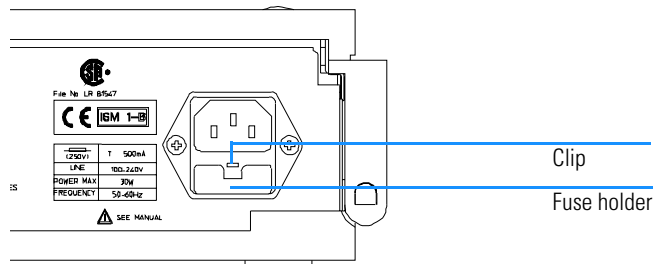

- 4 Remove the fuses from the fuse holders.

All Lamps are Off

- 5** Ensure the fuse wires inside the fuses are not broken. If a test meter is available, check the resistance of each fuse. A good fuse shows a low resistance (approximately 0 Ohm).
 - 6** If a fuse is defective (wire broken or high resistance), insert a new fuse.
 - 7** Reinsert the fuse holders and the power cable.
 - 8** Switch on the power switch.
- If the previous steps did not solve the problem, change the control assembly (see “Exchanging the Degasser Control Assembly and the Sensor Assembly” on page 60).

If the Status Indicator is Red

Sufficient vacuum is normally built up during the initial start-up and is maintained by turning on the vacuum pump whenever triggered by the vacuum sensor.

If the vacuum cannot be reached, or is lost faster than expected during operation, the micro vacuum degasser will be forced into an error state. Approximately 8 to 16 minutes after turning on the vacuum pump without reaching its normal operation modes the error LED is turned on and the vacuum pump and the solenoid will be disabled.

The error condition can be reset by turning the micro vacuum degasser off and on again. If the error condition persists the error will occur again after another 8 to 16 minutes.

The following described failure conditions will appear during the start-up procedure before the red error LED is turned on. Every power cycling of the degasser will give you 8 to 16 minutes of time to diagnose the failure conditions described on the following pages:

If the Status Indicator is Yellow and the Vacuum Pump is not Running

- ❑ Remove the top cover (see “Removing and Refitting the Top Cover” on page 50).
- ❑ Check the operation of the vacuum pump. Disconnect the vacuum tube from the sensor assembly to the vacuum chamber at the vacuum chamber (see “Overview of Internal Parts” on page 54) to adjust the pressure inside the vacuum chamber to ambient conditions. Switch the micro vacuum degasser off and on again. The vacuum pump should start immediately.

NOTE

As long as there is sufficient vacuum in the chamber the pump will not be turned on until triggered by the vacuum sensor.

- ❑ Use a test meter to check for + 24 V DC on the connector CN2 of the control assembly between pin 1 and 2 (see “Overview of Internal Parts” on page 54). This voltage is needed to operate the pump. If this voltage is low, exchange the control assembly (see “Exchanging the Degasser Control Assembly and the Sensor Assembly” on page 60).
- ❑ Check the resistance of the motor windings. The windings should have a resistance in the kOhm range (use a test meter to check resistance between red and blue, blue and black, black and red wires from connector CN2 to the pump). If the windings are broken or shortened replace the vacuum pump (see “Exchanging the Vacuum Pump” on page 57).

If the Status Lamp is Yellow and the Vacuum Pump Runs Continuously

Before starting the following troubleshooting procedures check that all tubes on the vacuum container, the pressure sensor, the vacuum pump and the solenoid valve are tight and connected properly. Then follow the troubleshooting instructions step by step to eliminate the individual parts one after the other as the sources of the problem.

Preparing to Measure the Pressure Sensor Readings

First of all remove the top cover (see “Removing and Refitting the Top Cover” on page 50). Use the “Overview of Internal Parts” on page 54 as a guide to identify the individual parts.

For test purposes and for monitoring the readings of the pressure sensor connect the auxiliary cable to the AUX output at the back of the micro vacuum degasser. Connect a test meter to wire 1 (white) and 2 (brown) of the auxiliary cable. When the vacuum chamber is at ambient pressure, a DC voltage measurement across these wires will give between 1.5 and 2.7 Volts (for pin connections see, “Auxiliary Cable” on page 72).

NOTE

The voltage readings given for the various modes are rough values. All values are set in the factory according to the vacuum level. Depending on the vacuum sensor batch variations this will result in different voltage readings. Regardless of the readings of the various stages no adjustment should be performed on the degasser electronics.

Troubleshooting

Eliminate the vacuum pump as the source of the problem.

- 1 Disconnect the sensor tube at position 4.
- 2 Remove the vacuum pump and place it on the top of the vacuum chamber
- 3 Disconnect the solenoid valve tube at position 9.
- 4 Switch the degasser into continuous mode (SW1 to 1).
- 5 Turn ON the degasser, wait 15 seconds, then connect the sensor assembly tube at position 9.

If the Status Lamp is Yellow and the Vacuum Pump Runs Continuously

Results

A pressure reading below 500 mV indicates a good functioning vacuum pump.

A pressure reading above 600 mV indicates that one of the pump chambers is contaminated or defective. In this case, disconnect the sensor tube (position 9) and let the pump run without load for 5 minutes.

Reconnect the sensor tube (position 9) and repeat the measurement. If the correct vacuum is obtained the contamination has been flushed away and the vacuum pump is functioning correctly.

If the pressure reading is still above 600 mV, the vacuum pump should be replaced (see “Exchanging the Vacuum Pump” on page 57).

- 6 Switch the degasser back to normal operation modes by turning SW1 back to 0.
- 7 Properly reconnect the tubings.

Eliminate the solenoid valve as the source of the problem.

Troubleshooting

- 1 Disconnect the solenoid valve tube at position 6.
- 2 Disconnect the sensor assembly tube at position 4.
- 3 Connect the sensor assembly tube at position 6.
- 4 Switch degasser into continuous mode by turning SW1 to 1.

Results

If the obtained pressure reading is similar to the result from the previous measurement (see above) when testing the pump (below 500 mV), the solenoid valve is functioning correctly.

If the obtained pressure reading is different (above 500 mV) from the results obtained when testing the pump (see above), the solenoid valve is defective and needs replacing (see “Exchanging the Solenoid Valve” on page 59).

- 5 Switch the degasser back to normal operation modes by turning SW1 back to 0.
- 6 Properly reconnect the tubings.

Eliminate the vacuum chamber 1 as the source of the problem.

Troubleshooting

- 1 Disconnect the solenoid valve tube at position 6.
- 2 Remove the vacuum pump and place it on the top of the vacuum chamber
- 3 Disconnect the solenoid valve tube at position 9.
- 4 Switch the degasser into continuous mode (SW1 to 1).
- 5 Disconnect the vacuum chamber 2 tube at position 2 and plug it.

If the Status Lamp is Yellow and the Vacuum Pump Runs Continuously

Results

- 6 Turn ON the degasser, wait 15 seconds, then connect the solenoid valve tube at position 9.

A pressure reading below 500 mV indicates a good working vacuum chamber 1.

A pressure reading above 600 mV indicates a leak in the vacuum chamber 1. If necessary exchange the vacuum chamber 1 (see “Exchanging a Vacuum Chamber” on page 55).

- 7 Switch the degasser back to normal operation modes by turning SW1 back to 0.
- 8 Properly reconnect the tubings and reinstall the pump.

Eliminate the vacuum chamber 2 as the source of the problem.

Follow the same procedure as for chamber 1.

At step 4: Disconnect the vacuum chamber 1 tube at position 1 and plug it

Exchange the electronic control assembly

If the above described troubleshooting steps do not lead to an identification of the problem, replace the electronic control module with the pressure sensor assembly (see “Exchanging the Degasser Control Assembly and the Sensor Assembly” on page 60).

Figure 11

Block Diagram

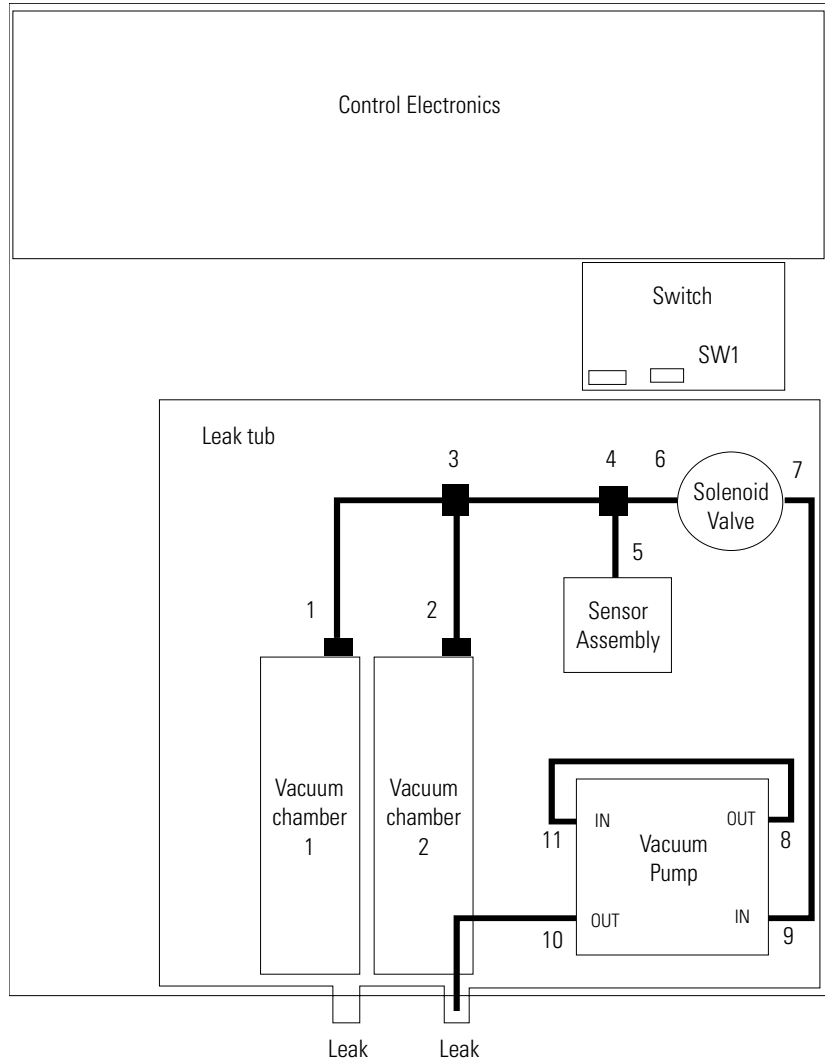

Repairing the Micro Vacuum Degasser

Instructions on how to repair the micro vacuum
degasser

Repairing the Micro Vacuum Degasser

Figure 12

Overview of Repair Procedures

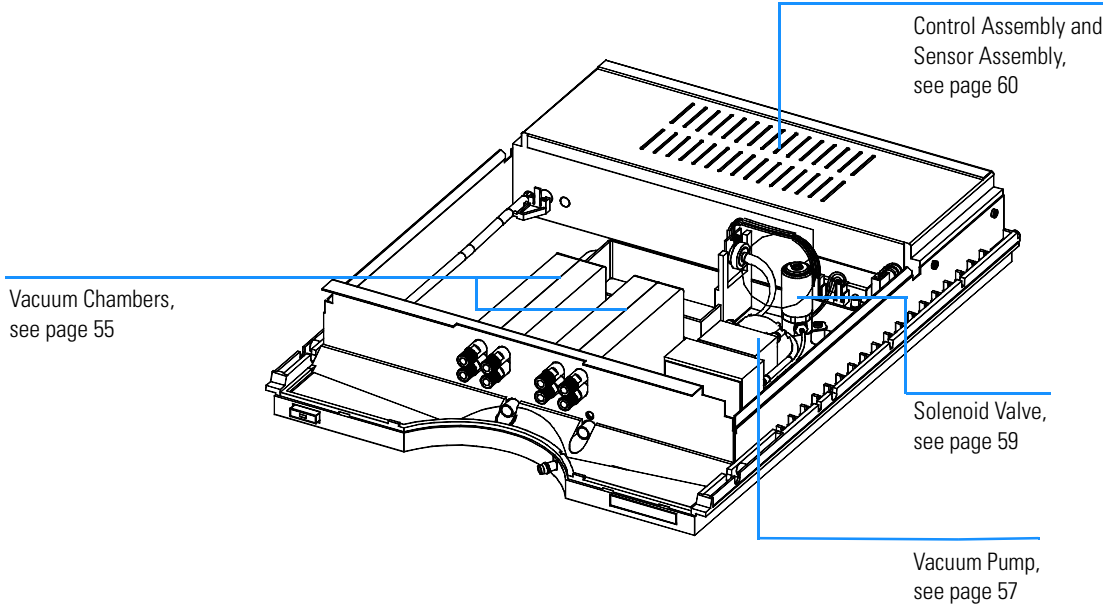

WARNING

The following procedures require opening the main cover of the micro vacuum degasser. To prevent personal injury, the power cable must be removed from the micro vacuum degasser before opening the cover. Do not connect the power cable to the micro vacuum degasser while the covers are removed.

WARNING

When opening capillary or tube fittings solvents may leak out. Please observe appropriate safety procedures (for example, goggles, safety gloves and protective clothing) as described in the material handling and safety data sheet by the solvent vendor, especially when toxic or hazardous solvents are used.

CAUTION

Electronic boards and components are sensitive to electrostatic discharge (ESD). In order to prevent damage always use an ESD protection (for example, the ESD wrist strap from the start up kit) when handling electronic boards and components.

CAUTION

The plates of the sheet metal of the degasser are very thin. Although they have been deburred, they are still quite sharp, and it is possible that you may cut your hands or fingers if you slide them along the edges of the sheet metal of the enclosure.

Therefore never slide your fingers along the edges of the enclosure.

The procedures in this section describe how to exchange internal parts. You must remove the micro vacuum degasser from the stack in order to open the main cover.

Cleaning the Instrument

The micro vacuum degasser case should be kept clean. Cleaning should be done with a soft cloth slightly dampened with water or a solution of water and a mild detergent. Do not use an excessively damp cloth that liquid can drip into the micro vacuum degasser.

WARNING

Do not let liquid drip into the micro vacuum degasser. It could cause shock hazard and it could damage the micro vacuum degasser.

Using the ESD Strap

Electronic boards are sensitive to electrostatic discharge (ESD). In order to prevent damage, always use an ESD strap supplied with the standard accessory kit when handling electronic boards and components.

Using the ESD Strap

- 1 Unwrap the first two folds of the band and wrap the exposed adhesive side firmly around your wrist.
- 2 Unroll the rest of the band and peel the liner from the copper foil at the opposite end.
- 3 Attach the copper foil to a convenient and exposed electrical ground.

Figure 13

Using the ESD Strap

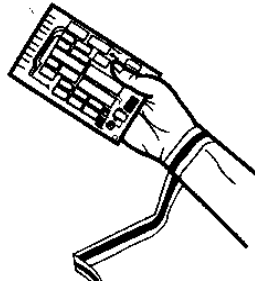

Removing and Refitting the Top Cover

WARNING

When opening capillary or tube fittings solvents may leak out. Please observe appropriate safety procedures (for example, goggles, safety gloves and protective clothing) as described in the material handling and safety data sheet by the solvent vendor, especially when toxic or hazardous solvents are used.

Tools required:

- ❑ Screwdriver Pozidriv #1

Preparations for this procedure:

- ❑ Switch off the micro vacuum degasser at the main power switch
- ❑ Disconnect the power cable and remote cable
- ❑ Disconnect all solvent tubes from the ports of the micro vacuum degasser
- ❑ Remove solvent cabinet from the micro vacuum degasser
- ❑ Remove micro vacuum degasser from the stack.

1 Remove the front panel.

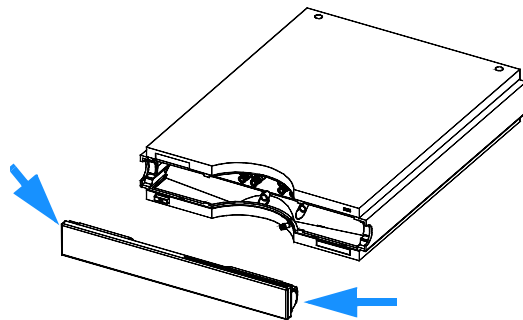

2 Unclip the clips on the top cover.

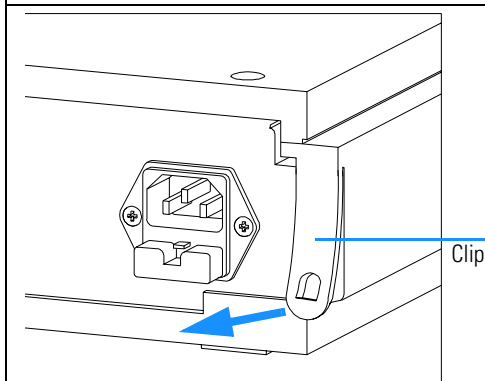

3 Lift the cover away.

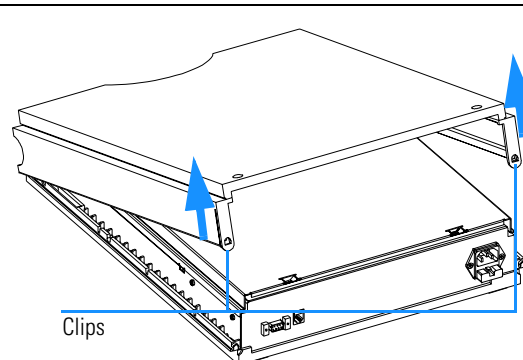

Repairing the Micro Vacuum Degasser
Removing and Refitting the Top Cover

4 Unscrew the screws on the top plate and remove the plate by lifting its back and then sliding the plate to the front.

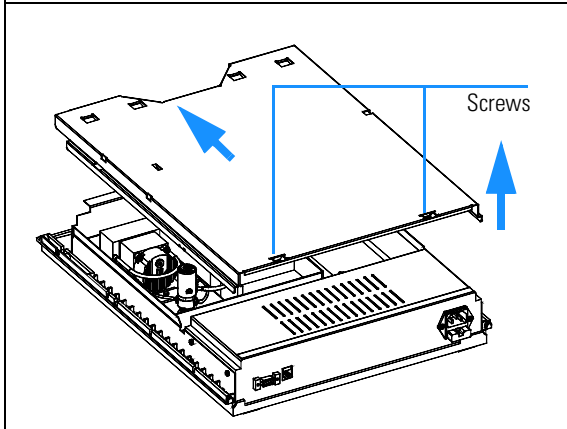

5 Place the metal cover onto the housing. Lower the front of the plate first, then slide panel to the back. Assume the four metal tabs of the panel slide underneath the Z-plane. Fix the two holding screws.

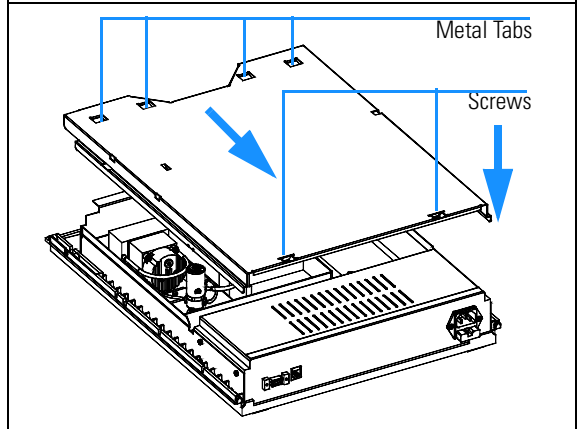

6 Replace the top cover. Ensure the clips are seated correctly.

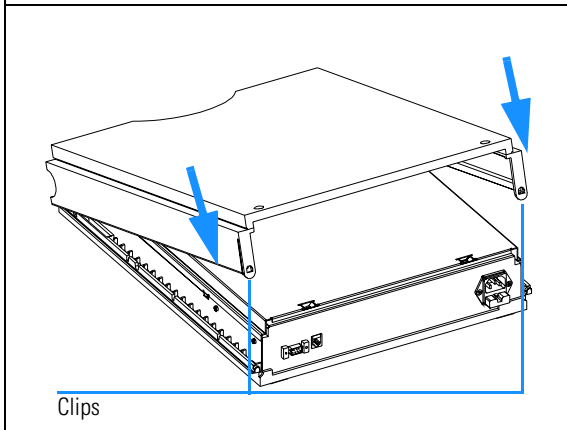

7 Reinstall the front cover.

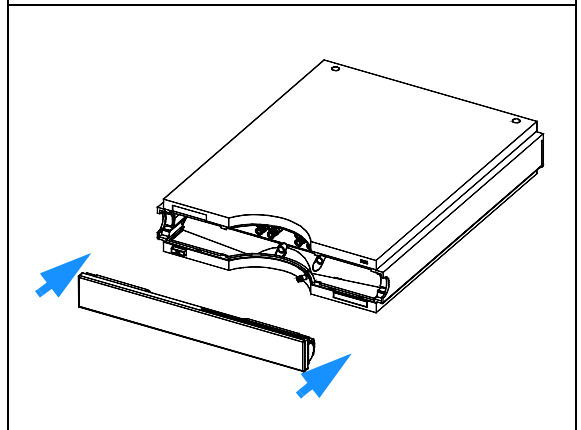

8 Reinstall the micro vacuum degasser in your system stack and connect the cables and capillaries and turn on the vacuum degasser.

Assembling the Main Cover

| | |
|-----------------------|--|
| When required | If cover is broken. |
| Tools required | None |
| Parts required | Cover kit 5062-8579 (includes base, top, left and right) |

NOTE The cover kit contains all parts, but it is not assembled.

WARNING In case you insert the left or right side in the opposite position, you may not be able to remove the side from the top part.

1 Place the top part on the bench and insert the left and right side into the top part.

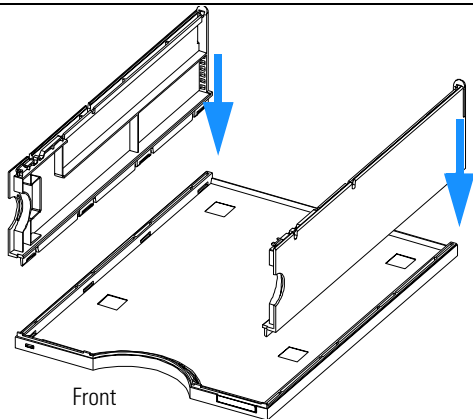

2 Replace the cover.

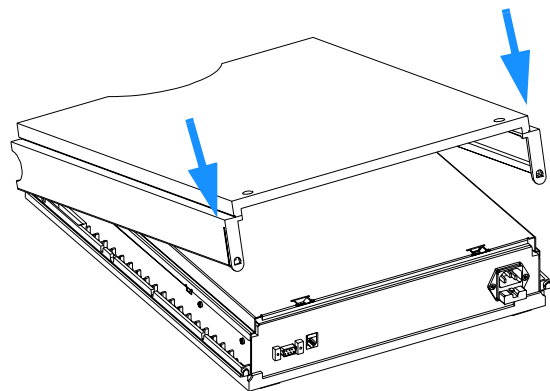

3 Replace the micro vacuum degasser in the stack and reconnect the cables and capillaries.

4 Turn on the vacuum degasser.

Exchanging the Status Light Pipe

| | |
|-----------------------|-----------------------------|
| When required | If part is broken |
| Tools required | Screwdriver Pozidriv#1 |
| Part required | Status light pipe 5041-8384 |

Preparation for this procedure:

- Remove the front cover and top cover, see “Removing and Refitting the Top Cover” on page 50.

1 The status light pipe is clipped into the top cover.

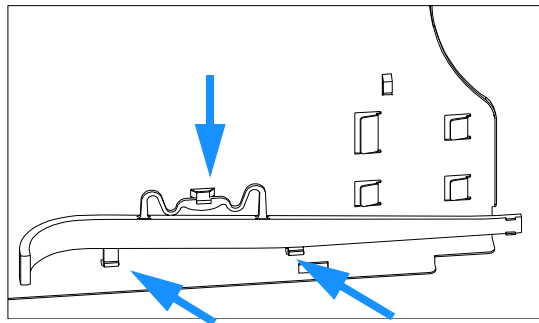

- 2** Replace the top cover, see “Removing and Refitting the Top Cover” on page 50.

Overview of Internal Parts

Figure 14 shows a top view of the micro vacuum degasser. It shows the connections of the vacuum tubes as well as the electrical connections at the control assembly.

Figure 14 **Top View of the Micro Vacuum Degasser**

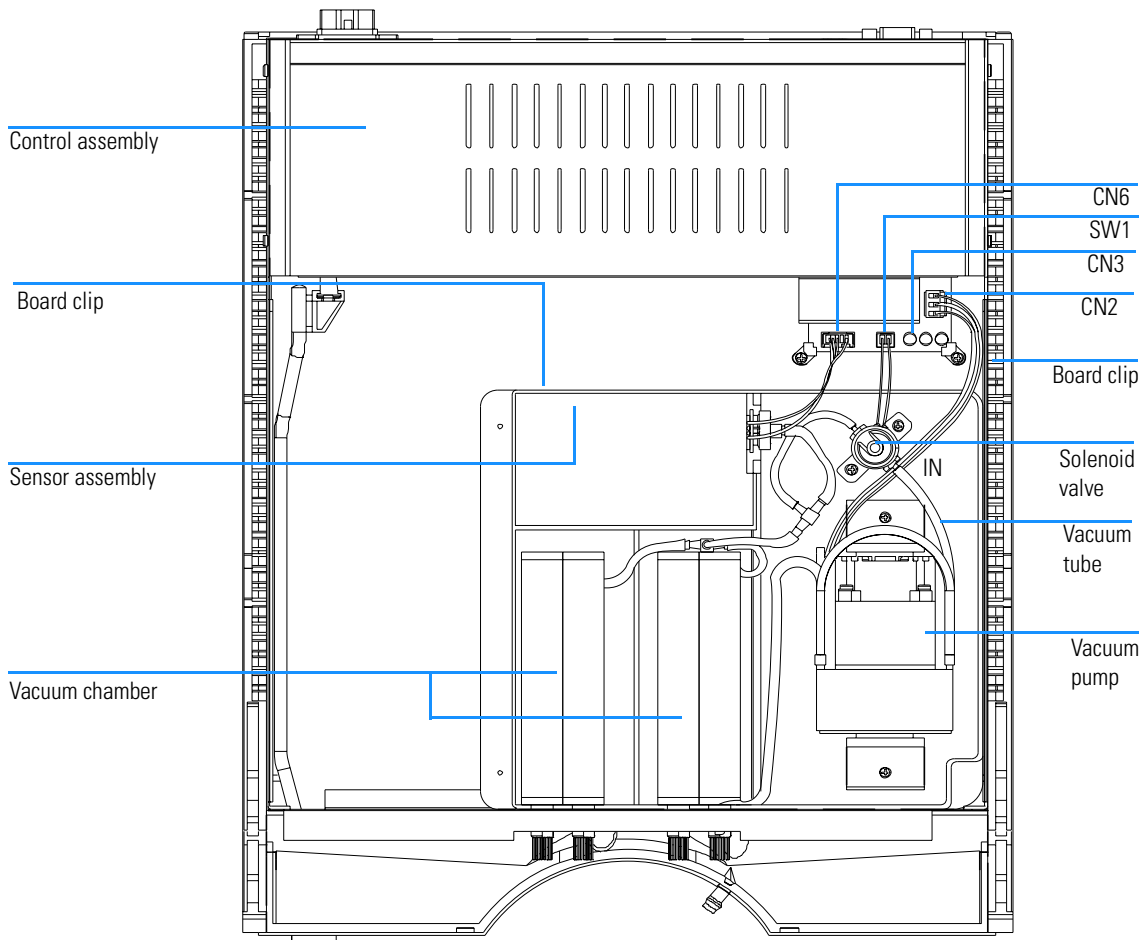

Exchanging a Vacuum Chamber

| | |
|-----------------------|---|
| When required | If internal membrane defective or vacuum chamber damaged |
| Tools required | Screwdriver Pozidriv #1 |
| Material | Vacuum chamber, G1379-60001 |
| Preparation | Disconnect the solvent inlet tubes at the degasser inlet ports Remove the solvent cabinet from the micro vacuum degasser |

WARNING Drain any remaining solvents from the degassing channels before removing the vacuum chamber from the micro vacuum degasser.

- 1 Disconnect a solvent tube of one of the channels from your pump.
- 2 Connect syringe adapter to the disconnected solvent tube.
- 3 Push syringe adapter onto syringe.
- 4 Pull syringe plunger to draw solvent out of degasser and tubing. Continue to draw solvent into syringe until there is no solvent in the tubing.
- 5 Repeat step 1 to step 4 for other solvent channels.
- 6 Disconnect outlet tubes from the vacuum degasser.
- 7 Remove top cover, see “Removing and Refitting the Top Cover” on page 50.
- 8 Remove tube coming from the vacuum chambers 1 and 2 at the T-connector (vacuum chamber tube, sensor assembly tube, solenoid assembly tube).
- 9 Loosen the 2 screws which maintain the vacuum chamber leak reservoir.
- 10 Slide the reservoir out of the Z-plane.
- 11 Remove the suspect chamber and install the new one.
- 12 Put the reservoir in place.
- 13 Reconnect the tube from the vacuum chambers to the T-connector.
- 14 Replace the 2 screws which maintain the vacuum chamber leak reservoir.
- 15 Reconnect all inlet and outlet tubes to the vacuum chamber, see Figure 7.
- 16 Refit the cover, see “Removing and Refitting the Top Cover” on page 50.

Repairing the Micro Vacuum Degasser
Exchanging a Vacuum Chamber

Figure 15

Exchanging a Vacuum Chamber

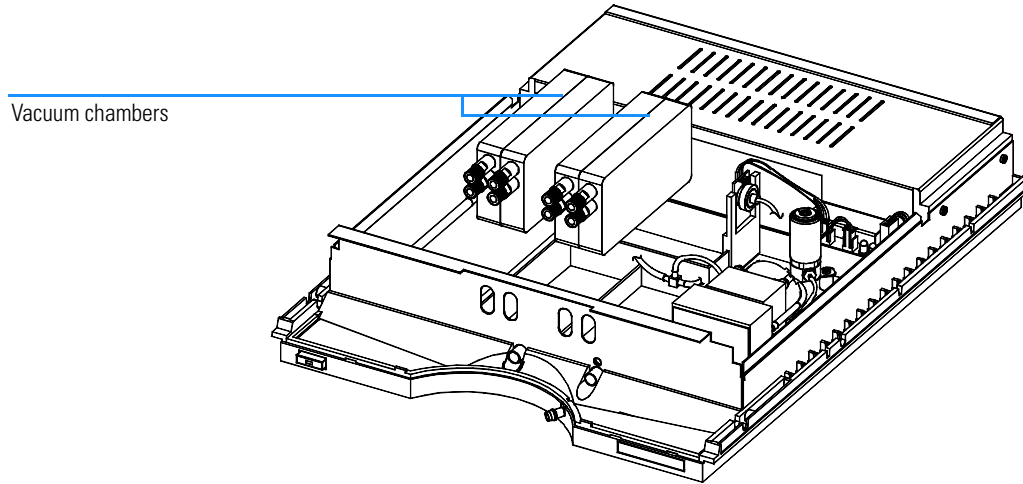

Exchanging the Vacuum Pump

| | |
|-----------------------|---|
| When required | If not generating sufficient vacuum or electrically defective |
| Tools required | Screwdriver Pozidriv #1 |
| Part required | Vacuum pump, G1322-60000 |

- 1** Remove Top Cover, see “Removing and Refitting the Top Cover” on page 50.
- 2** Disconnect vacuum pump cable from connector CN2 at the control assembly (for identifying internal parts see “Overview of Internal Parts” on page 54).
- 3** Using a Pozidriv screwdriver #1 loosen and remove the two holding screws of the vacuum pump.
- 4** Remove the fixing plates.
- 5** Lift the vacuum pump, disconnect the inlet tube (connected to the solenoid assembly) and take the pump out of the unit.
- 6** Connect the tubing from the solenoid valve to the new vacuum pump inlet.
- 7** Place the vacuum pump in its position.
- 8** Place the fixing plates onto the rubber feet of the pump.
- 9** Insert the holding screws and fix them.
- 10** Connect the vacuum pump cable to the control assembly (CN2).
- 11** Refit the cover, see “Removing and Refitting the Top Cover” on page 50.

Repairing the Micro Vacuum Degasser
Exchanging the Vacuum Pump

Figure 16 **Exchanging the Vacuum Pump**

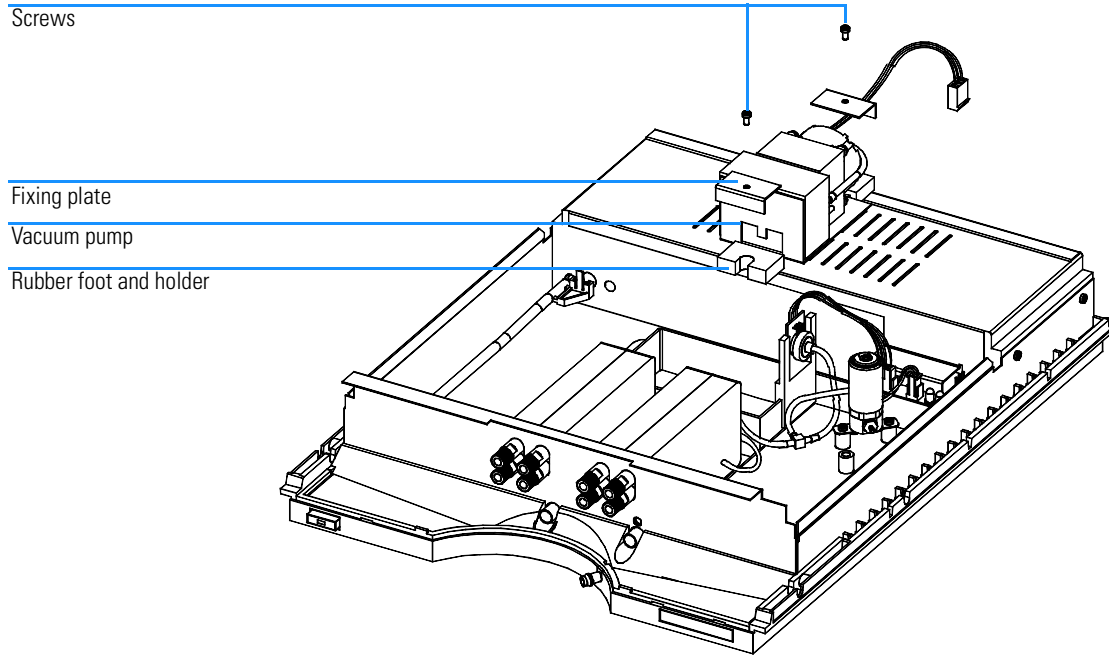

Exchanging the Solenoid Valve

| | |
|-----------------------|--|
| When required | Valve not switching correctly or leaking |
| Tools required | Screwdriver Pozidriv #1 |
| Part required | Solenoid valve G1322-60003 |

- 1 Remove Top Cover, see “Removing and Refitting the Top Cover” on page 50.
- 2 Disconnect the solenoid connector from the control board (CN3) (for identifying internal parts see “Overview of Internal Parts” on page 54).
- 3 Loosen and remove the holding screws of the solenoid valve.
- 4 Loosen and remove the two screws of the holding plate at the solenoid.
- 5 Disconnect inlet and outlet tubes from the solenoid valve.
- 6 Fix the holding plate to the new solenoid valve.
- 7 Connect the two vacuum tubes to the solenoid valve. The inlet of the solenoid is labeled IN and is connected to the vacuum pump.
- 8 Fix the solenoid valve with the two screws to its holder.
- 9 Connect the solenoid cable to the control board (CN3).
- 10 Refit the cover, see “Removing and Refitting the Top Cover” on page 50.

Figure 17 Exchanging the Solenoid Valve

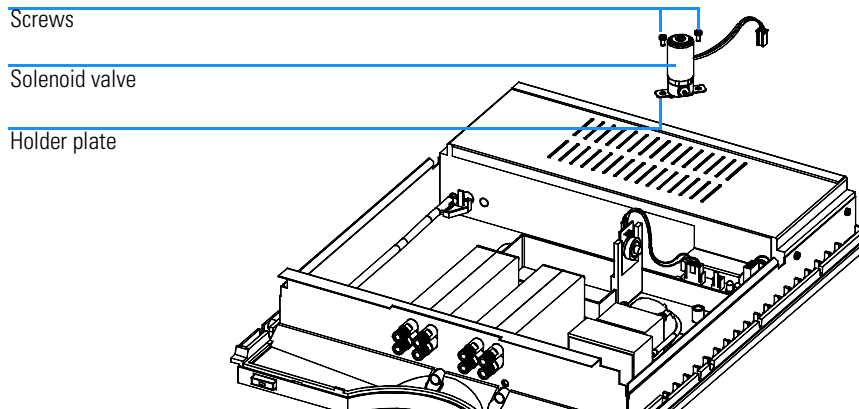

Exchanging the Degasser Control Assembly and the Sensor Assembly

| | |
|-----------------------|--|
| When required | No power available, vacuum pump or switching valve not activated |
| Tools required | Screwdriver Pozidriv #1 |
| Part required | Degasser control assembly (includes the sensor assembly) G1322-66500 |

WARNING The degasser control assembly does not include any serviceable parts and should not be opened.

NOTE Sensor assembly and degasser control assembly are a matched pair and must be exchanged together.

- 1 Remove Top Cover, see “Removing and Refitting the Top Cover” on page 50.
- 2 Disconnect all connectors at the control assembly board (for identifying internal parts see “Overview of Internal Parts” on page 54).
- 3 Loosen and remove the two holding clips at the control board of the control assembly.
- 4 Unclip the power switch light pipe at the degasser control assembly power switch.
- 5 Remove the four holding screws at the side panel — two at the left side, two on the right side of the micro vacuum degasser.
- 6 Lift the degasser control assembly out of the unit.
- 7 Remove the coupler from the control assembly and place it onto the power switch in the exchange control assembly.
- 8 Loosen the clip of the sensor board and remove it from its slot in the vacuum chamber.
- 9 Slide the new sensor board into the slots of the vacuum chamber and fix the clip.
- 10 Place a new degasser control assembly into the unit and fix with the four holding screws to the side panels.

Exchanging the Degasser Control Assembly and the Sensor Assembly

- 11 Clip the power switch light pipe to the degasser control assembly power switch.
- 12 Replace the two holding clips and fix the holding screws.
- 13 Connect all the cables to the control board (sensor assembly cable to CN6, solenoid valve cable to CN3, pump cable to CN2).
- 14 Refit the cover, see “Removing and Refitting the Top Cover” on page 50.

Figure 18 Exchanging the Degasser Control Assembly

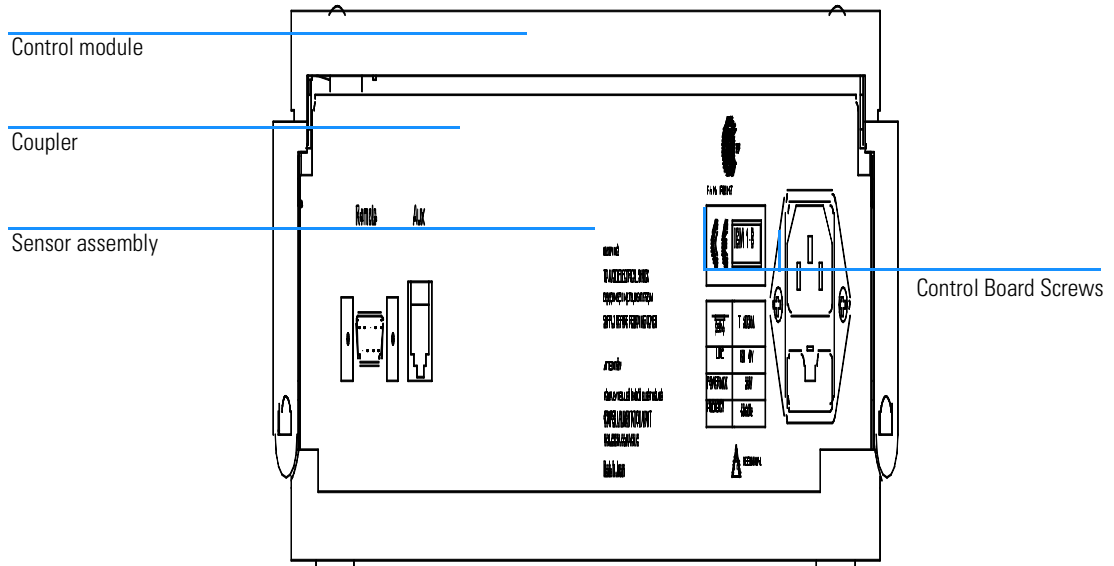

Repairing the Micro Vacuum Degasser

Exchanging the Degasser Control Assembly and the Sensor Assembly

Parts and Materials

Detailed illustrations and listings for parts and materials identification

Micro Vacuum Degasser Parts

Figure 19 **Micro Vacuum Degasser Parts**

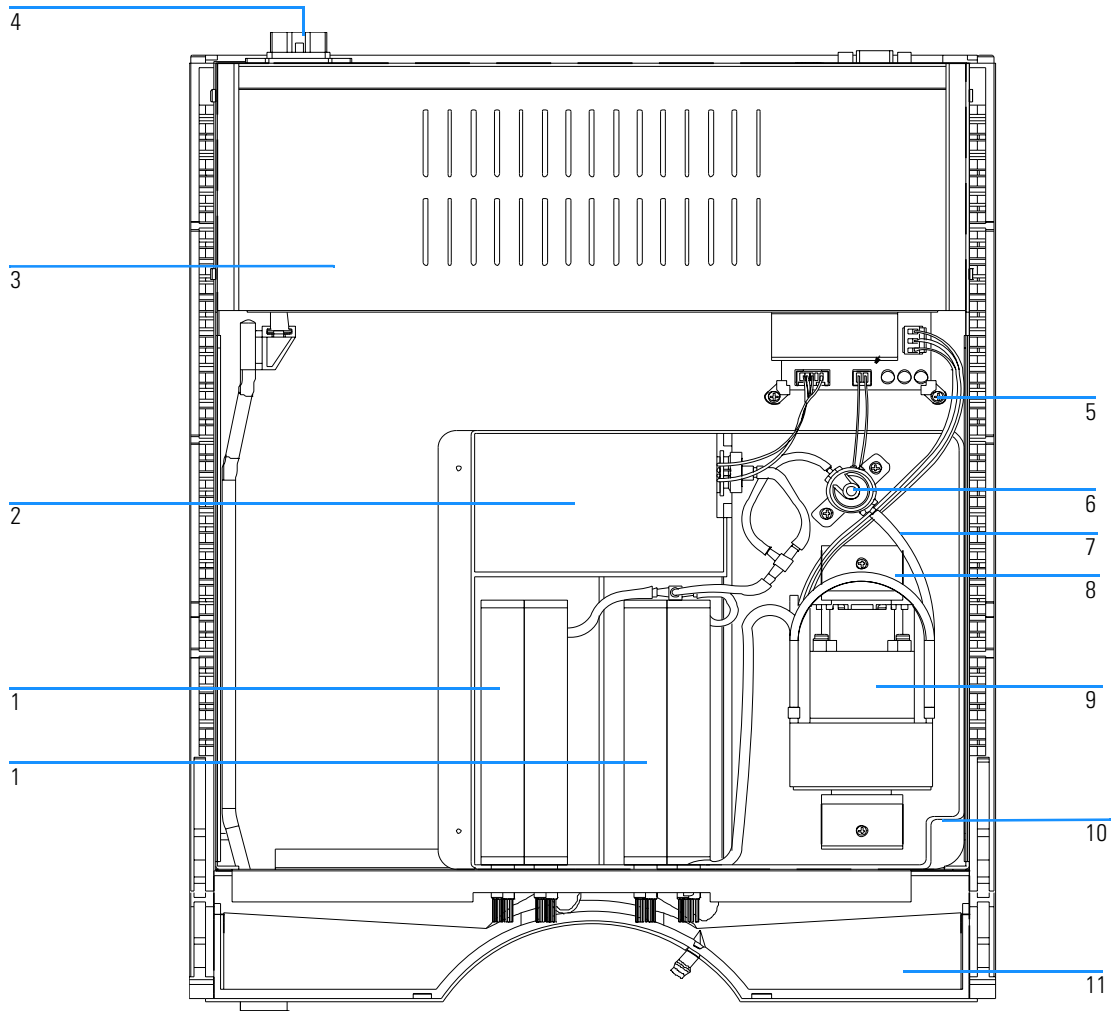

Micro Vacuum Degasser Parts**Table 5**

| Micro Vacuum Degasser Parts | | |
|------------------------------------|--|--------------------|
| Item | Description | Part Number |
| 1 | Vacuum chamber | G1379-60001 |
| 2 | Sensor assembly (included in the control assembly) | no PN |
| 3 | Vacuum degasser control assembly | G1322-66500 |
| 4 | Fuse 500 mA | 2110-0458 |
| 5 | Board clip | G1322-43100 |
| 6 | Solenoid valve | G1322-60003 |
| 7 | Vacuum tube set | G1379-67300 |
| 8 | Fixing plate | no PN |
| 9 | Vacuum pump | G1322-60000 |
| 10 | Leak tray internal | G1379-27300 |
| 11 | Leak pan, degasser | G1379-47300 |

Cover Parts

Table 6

Cover Parts

| Item | Description | Part Number |
|------|--|-------------|
| 1 | Set of all plastic covers, top-side-base | 5062-8579 |
| 2 | Front cover | 5062-8580 |
| 3 | Logo plate, Agilent 1100 | 5042-1384 |
| 4 | Tube clip | 5041-8387 |

Figure 20

Cover Parts

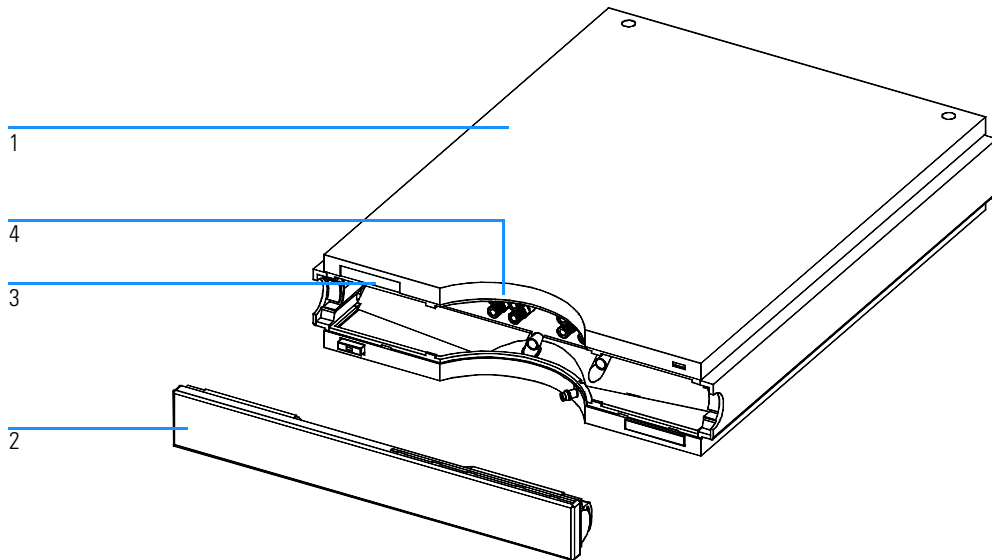

Sheet Metal Kit

Table 7

Sheet Metal Kit

| Item | Description | Part Number |
|------|--|-------------|
| 1 | Sheet metal kit, includes base and top plate | G1379-68701 |

Figure 21

Sheet Metal Kit

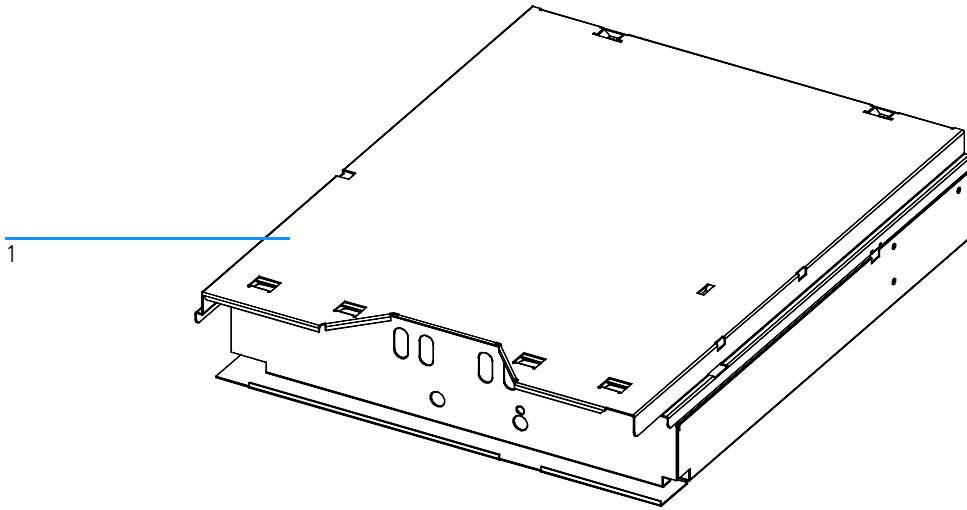

Power and Status Light Pipes

Table 8

Power and Status Light Pipes

| Item | Description | Part Number |
|------|---------------------------|-------------|
| 1 | Power switch coupler | 5041-8383 |
| 2 | Light pipe – power switch | 5041-8382 |
| 3 | Power switch button | 5041-8381 |
| 4 | Light pipe – status lamp | 5041-8384 |

Figure 22

Power and Status Light Pipes

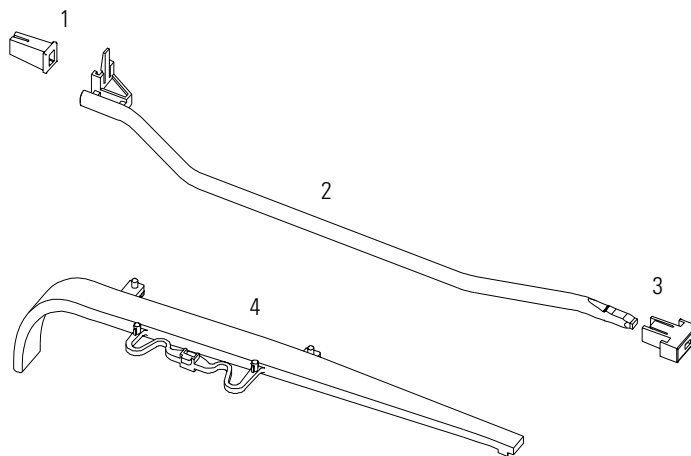

Accessory Kit

Table 9

Accessory Kit G1322-68705

| Item | Description | Part Number |
|-------------|---|--------------------|
| 1 | Syringe* | 5062-8534 |
| 2 | Syringe adapter | 9301-1337 |
| 3 | Solvent tubing kit (4 tubes degasser to pump) | G1322-67300 |
| 4 | Waste tube** | 5062-2463 |
| | Mounting Tool | 0100-1710 |

* Reorder number (pack of 10)

**Reorder number (5m)

Cable Overview

WARNING

Never use cables other than the ones supplied by Agilent Technologies to ensure proper functionality and compliance with safety or EMC regulations.

Table 10

Cable Overview

| Type | Description | Part Number |
|---------------|-------------------------------------|--------------------|
| Remote cables | Agilent 1100 modules | 5061-3378 |
| | HP 1050 modules | |
| | HP 1046A FLD | |
| | General purpose | 01046-60201 |
| Auxiliary | Agilent 1100 Series vacuum degasser | G1322-61600 |

Remote Cables

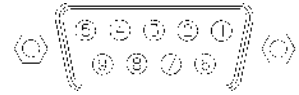

One end of these cables provides a Agilent Technologies APG (Analytical Products Group) remote connector to be connected to Agilent 1100 Series modules. The other end depends on the instrument to be connected to.

Agilent 1100 to HP 1050, HP 1046A or 35900 A/D Converters

| Connector 5061-3378 | Pin 3394 | Pin Agilent 1100 | Signal Name | Active (TTL) |
|---------------------|------------|------------------|----------------|--------------|
| | 1 - White | 1 - White | Digital ground | |
| | 2 - Brown | 2 - Brown | Prepare Run | Low |
| | 3 - Gray | 3 - Gray | Start | Low |
| | 4 - Blue | 4 - Blue | Shut Down | Low |
| | 5 - Pink | 5 - Pink | not connected | |
| | 6 - Yellow | 6 - Yellow | Power On | High |
| | 7 - Red | 7 - Red | Ready | High |
| | 8 - Green | 8 - Green | Stop | Low |
| | 9 - Black | 9 - Black | Start request | Low |

Agilent 1100 to General Purpose

| Connector 01046-60201 | Universal | Pin Agilent 1100 | Signal Name | Active (TTL) |
|-----------------------|-----------|------------------|----------------|--------------|
| | | 1 - White | Digital ground | |
| | | 2 - Brown | Prepare run | Low |
| | | 3 - Gray | Start | Low |
| | | 4 - Blue | Shut down | Low |
| | | 5 - Pink | not connected | |
| | | 6 - Yellow | Power on | High |
| | | 7 - Red | Ready | High |
| | | 8 - Green | Stop | Low |
| | | 9 - Black | Start request | Low |

Auxiliary Cable



One end of this cable provides a modular plug to be connected to the vacuum degasser. The other end is for general purpose.

Agilent 1100 Series Vacuum Degasser to General Purpose

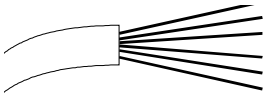
| Connector G1322-61600 | Color | Pin Agilent 1100 | Signal Name |
|---|--------|------------------|-----------------|
|  | White | 1 | Ground |
| | Brown | 2 | Pressure signal |
| | Green | 3 | Continuous Mode |
| | Yellow | 4 | |
| | Grey | 5 | DC + 5 V IN |
| | Pink | 6 | Vent |

Theory of Operation

The vacuum degasser's operation and electronics

How the Electronics Work

The vacuum degasser has two different normal operation modes and a continuous mode. In operation mode 1 the vacuum degasser works around a defined set point (115 Torr). Due to environmental conditions it is possible that the vacuum degasser cannot reach the pre-defined set point. Under this condition the operation mode 2 becomes active and the vacuum pump is activated in defined time intervals (vacuum level 115 to 190 Torr). In case of a malfunction of the vacuum degasser (vacuum level above 190 Torr) the instrument is turned into the error mode.

Figure 23

Operation Modes of the Vacuum Degasser

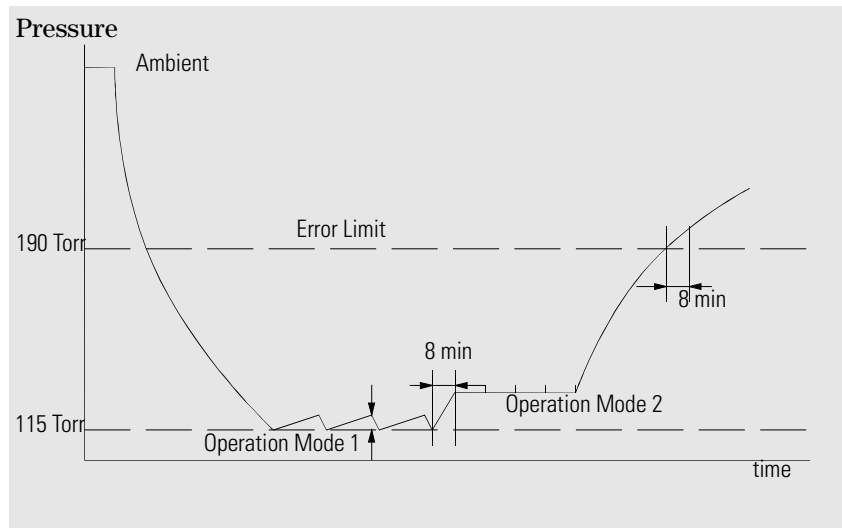

The main function of the vacuum degasser control assembly is to control the vacuum pump and to check the vacuum in the vacuum container.

The power section of the control assembly comprises a switching power supply that generates + 24 V from line voltage. The + 24 V is used to drive the vacuum pump and the solenoid valve. The electronic control circuit uses + 12 V which is generated from the + 24 V.

The pressure sensor is connected to the vacuum chamber and checks for the correct vacuum in the system.

The amplifier and comparator circuit determines the working range of the vacuum that has to be built up. When the vacuum degasser is turned on and the vacuum in the chamber is not within working range (above error limit of 190 Torr), the amplifier and comparator circuit sends a signal to the vacuum pump driver and the timers of the vacuum pump (timer 1) and the solenoid valve (timer 2).

The vacuum pump is turned on immediately while the solenoid valve closing is delayed by 15 seconds. This time delay allows the vacuum pump to start without load before it is connected to the vacuum chamber. The status indicator turns yellow when the pump is activated. The status lamp is turned off as soon as the vacuum is below the error limit.

When the vacuum in the chamber reaches its operation mode 1 (approximately 115 Torr) the amplifier and comparator circuit turns off the solenoid valve and the vacuum pump is turned off by a timer with a delay of 15 seconds.

As soon as the pressure sensor detects that the limit of the operation mode 1 has been exceeded (e.g. when dissolved gas from the solvent diffused into the vacuum chamber) the vacuum pump is started again as described before.

The pressure signal is available at the auxiliary output. It allows to monitor the vacuum system. The upper limit of operation mode 1 is 600 mV. Values below 600 mV on the pressure output indicate sufficient vacuum in the chamber. If the 600 mV are exceeded the vacuum pump will be started to keep the vacuum within its working limit.

The amplifier and comparator circuit also activates the timer 3 when the vacuum in the vacuum chambers is below operation mode 1. The timer 3 is reset when operation mode 1 is reached within a maximum of 8 minutes. If operation mode 1 is not reached and the time (8 minutes) of timer 3 elapsed, the timer mode (operation mode 2) is activated. In this mode the vacuum pump is automatically turned on every 2 minutes for a time frame of 30 seconds. Timers 1 and 2 are activated as described earlier.

The error monitor continuously checks the error limit of the degasser (190 Torr). If the error limit is exceeded (for example, leak in chamber), the error timer is activated and the yellow status indicator lamp is turned on. The vacuum pump is turned on continuously. If the vacuum pump cannot reach either of its two operation modes within 8 minutes (error timer limit) the error driver is activated. The error driver will deactivate the vacuum pump

and solenoid valve. The status lamp turns red and the error output on the remote connector will be activated.

The error output at the remote connector provides a *contact closure* (potential free open collector maximum load 35 V DC/50 mA) as long as the error condition is active. The error condition is set (closed) when the status light shows the error condition (red).

The continuous mode overwrites all other operation modes of the degasser. When activated (switch SW1 on the electronic board or via the auxiliary cable) the vacuum pump is forced into continuous mode and is turned on as long as the degasser is switched on.

Figure 24 Block Diagram — Vacuum Degasser Control Assembly

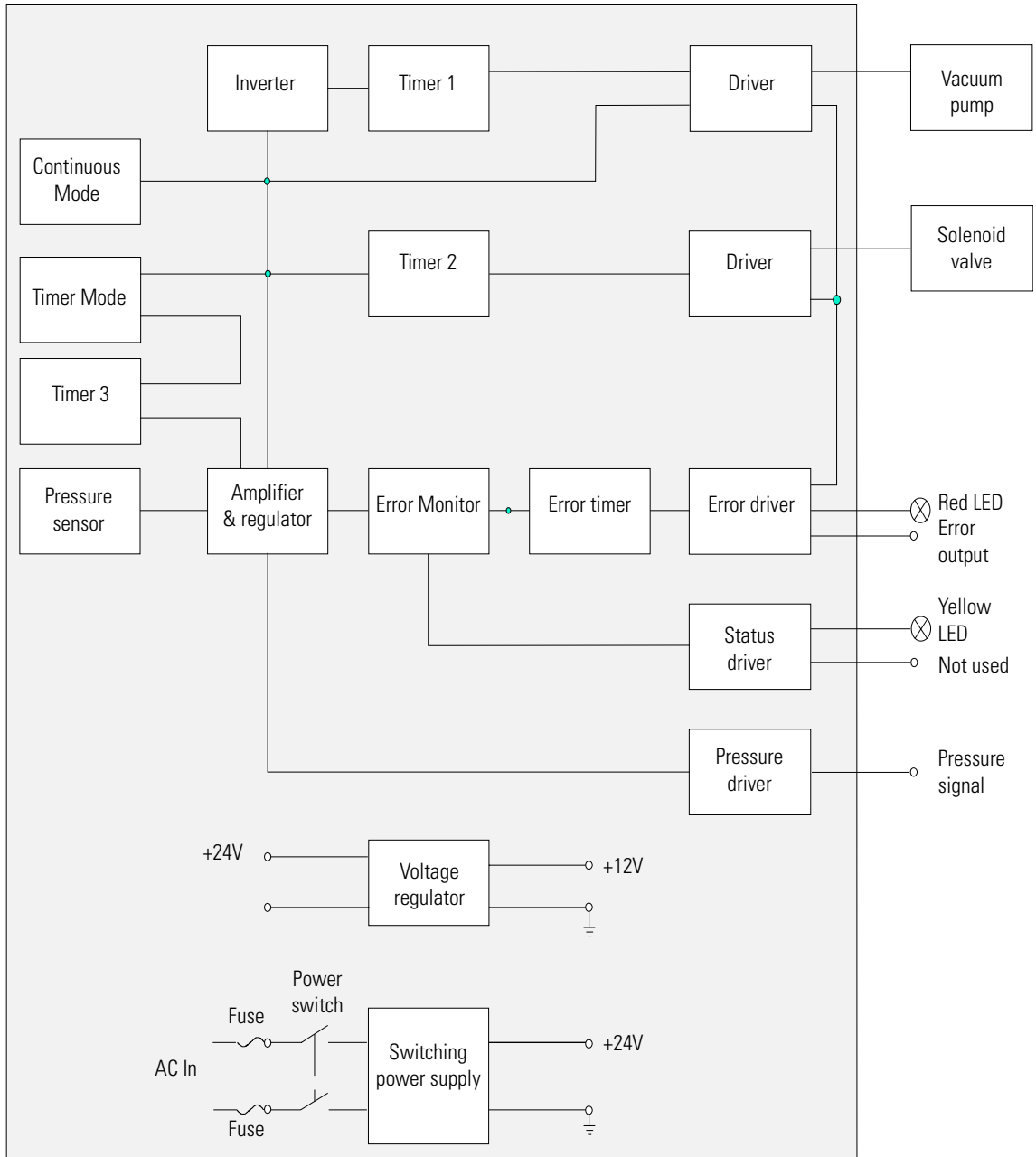

Specifications

Performance specifications of the micro vacuum degasser

Performance Specifications

Table 11

Performance Specifications Agilent 1100 Vacuum Degasser

| Type | Specification |
|-----------------------------------|---|
| Maximum flow rate | 0 - 10 ml/min per channel 5 - 10 ml/min at reduced degassing performance |
| Number of channels | 4 |
| Internal volume per channel | Typically 1 ml per channel |
| Materials in contact with solvent | PTFE, FEP, PEEK |
| pH range | 1 – 14 |
| Analog output (AUX) | For pressure monitoring, range 0 – 3 V |

NOTE

The Agilent 1100 Series micro vacuum degasser has been tested for evaporation of solvents into the atmosphere by an independent institute with approved methods. The tests were performed with Methanol (BIA Nr. 7810) and Acetonitrile (NIOSH, Nr. 1606). Evaporation of these solvents into the atmosphere when operating the degasser was below the limits of detection.

**Legal, Safety and
Warranty Information**

Warranty Statement

All Chemical Analysis Products

Agilent Technologies warrants its chemical analysis products against defects in materials and workmanship. For details of the warranty period in your country, call Agilent. During the warranty period, Agilent will, at its option, repair or replace products which prove to be defective. Products that are installed by Agilent are warranted from the installation date, all others from the ship date.

If buyer schedules or delays installation more than 30 days after delivery, then warranty period starts on 31st day from date of shipment (60 and 61 days, respectively for products shipped internationally).

Agilent warrants that its software and firmware designed by Agilent for use with a CPU will execute its programming instructions when properly installed on that CPU. Agilent does not warrant that the operation of the CPU, or software, or firmware will be uninterrupted or error-free.

Limitation of Warranty

Onsite warranty services are provided at the initial installation point. Installation and onsite warranty services are available only in Agilent service travel areas, and only in the country of initial purchase unless buyer pays Agilent international prices for the product and services. Warranties requiring return to Agilent are not limited to the country of purchase.

For installation and warranty services outside of Agilent's service travel area, Agilent will provide a quotation for the applicable additional services.

If products eligible for installation and onsite warranty services are moved from the initial installation point, the warranty will remain in effect only if the customer purchases additional inspection or installation services, at the new site.

The foregoing warranty shall not apply to defects resulting from:

- 1 improper or inadequate maintenance, adjustment, calibration, or operation by buyer,
- 2 buyer-supplied software, hardware, interfacing or consumables,
- 3 unauthorized modification or misuse,

Warranty Statement

- 4 operation outside of the environmental and electrical specifications for the product,
- 5 improper site preparation and maintenance, or
- 6 customer induced contamination or leaks.

THE WARRANTY SET FORTH IS EXCLUSIVE AND NO OTHER WARRANTY, WHETHER WRITTEN OR ORAL, IS EXPRESSED OR IMPLIED. AGILENT SPECIFICALLY DISCLAIMS THE IMPLIED WARRANTIES OF MERCHANTABILITY AND FITNESS FOR A PARTICULAR PURPOSE.

Limitation of Remedies and Liability

THE REMEDIES PROVIDED HEREIN ARE BUYER'S SOLE AND EXCLUSIVE REMEDIES. IN NO EVENT SHALL AGILENT BE LIABLE FOR DIRECT, INDIRECT, SPECIAL, INCIDENTAL, OR CONSEQUENTIAL DAMAGES (INCLUDING LOSS OF PROFITS) WHETHER BASED ON CONTRACT, TORT OR ANY OTHER LEGAL THEORY.

Responsibilities of the Customer

The customer shall provide:

- 1 access to the products during the specified periods of coverage to perform maintenance,
- 2 adequate working space around the products for servicing by Agilent personnel,
- 3 access to and use of all information and facilities determined necessary by Agilent to service and/or maintain the products (insofar as these items may contain proprietary or classified information, the customer shall assume full responsibility for safeguarding and protection from wrongful use),
- 4 routine operator maintenance and cleaning as specified in the Agilent operating and service manuals, and
- 5 consumables such as paper, disks, magnetic tapes, ribbons, inks, pens, gases, solvents, columns, syringes, lamps, septa, needles, filters, frits, fuses, seals, detector flow cell windows, and so on.

Warranty Statement

Responsibilities of Agilent Technologies

Agilent Technologies will provide warranty services as described in Table 12.

Table 12

Warranty Services

| Services During Warranty* | Warranty Period** | Type |
|--|--------------------------|-------------------|
| Agilent 1100 Series of Modules | 1 Year | Onsite |
| GC, LC, UV-Visible, and LAS supplies and accessories | 90 Days | Onsite |
| Columns and Consumables*** | 90 Days | Return to Agilent |
| Gas Discharge and Tungsten Lamps | 30 Days | Return to Agilent |
| Repairs performed on-site by Agilent**** | 90 Days | Onsite |

* This warranty may be modified in accordance with the law of your country. Please consult your local Agilent office for the period of the warranty, for shipping instructions and for the applicable wording of the local warranty.

** Warranty services are included as specified for Analytical products and options purchased concurrently provided customer is located within a Agilent defined travel area. Agilent warranty service provides for 8 a.m. to 5 p.m. on-site coverage Monday through Friday, exclusive of Agilent holidays.

*** Columns and Consumables are warranted to be free from defects for a period of 90 days after shipment and will be replaced on a return-to-Agilent basis if unused.

**** Agilent repair warranty is limited to only the item repaired or replaced.

Safety Information

The following general safety precautions must be observed during all phases of operation, service, and repair of this instrument. Failure to comply with these precautions or with specific warnings elsewhere in this manual violates safety standards of design, manufacture, and intended use of the instrument. Agilent Technologies assumes no liability for the customer's failure to comply with these requirements.

General

This is a Safety Class I instrument (provided with terminal for protective earthing) and has been manufactured and tested according to international safety standards.

Operation

Before applying power, comply with the installation section. Additionally the following must be observed.

Do not remove instrument covers when operating. Before the instrument is switched on, all protective earth terminals, extension cords, auto-transformers, and devices connected to it must be connected to a protective earth via a ground socket. Any interruption of the protective earth grounding will cause a potential shock hazard that could result in serious personal injury. Whenever it is likely that the protection has been impaired, the instrument must be made inoperative and be secured against any intended operation.

Make sure that only fuses with the required rated current and of the specified type (normal blow, time delay, and so on) are used for replacement. The use of repaired fuses and the short-circuiting of fuseholders must be avoided.

Some adjustments described in the manual, are made with power supplied to the instrument, and protective covers removed. Energy available at many points may, if contacted, result in personal injury.

Any adjustment, maintenance, and repair of the opened instrument under voltage should be avoided as much as possible. When inevitable, this should be carried out by a skilled person who is aware of the hazard involved. Do not attempt internal service or adjustment unless another person, capable of rendering first aid and resuscitation, is present. Do not replace components with power cable connected.

Safety Information

Do not operate the instrument in the presence of flammable gases or fumes. Operation of any electrical instrument in such an environment constitutes a definite safety hazard.

Do not install substitute parts or make any unauthorized modification to the instrument.

Capacitors inside the instrument may still be charged, even though the instrument has been disconnected from its source of supply. Dangerous voltages, capable of causing serious personal injury, are present in this instrument. Use extreme caution when handling, testing and adjusting.



When working with solvents please observe appropriate safety procedures (e.g. goggles, safety gloves and protective clothing) as described in the material handling and safety data sheet by the solvent vendor, especially when toxic or hazardous solvents are used.

Safety Symbols

Table 13 shows safety symbols used on the instrument and in the manuals.

Table 13

Safety Symbols

| Symbol | Description |
|---|---|
|  | The apparatus is marked with this symbol when the user should refer to the instruction manual in order to protect the apparatus against damage. |
|  | Indicates dangerous voltages. |
|  | Indicates a protected ground terminal. |

Safety Information

WARNING

A warning alerts you to situations that could cause physical injury or damage to the equipment. Do not proceed beyond a warning until you have fully understood and met the indicated conditions.

CAUTION

A caution alerts you to situations that could cause a possible loss of data. Do not proceed beyond a caution until you have fully understood and met the indicated conditions.

Radio Interference

Manufacturer's Declaration

This is to certify that this equipment is in accordance with the Radio Interference Requirements of Directive FTZ 1046/1984. The German Bundespost was notified that this equipment was put into circulation, the right to check the series for compliance with the requirements was granted.

Test and Measurement

If test and measurement equipment is operated with equipment unscreened cables and/or used for measurements on open set-ups, the user has to assure that under operating conditions the radio interference limits are still met within the premises.

Sound Emission

Manufacturer's Declaration

This statement is provided to comply with the requirements of the German Sound Emission Directive of 18 January 1991.

This product has a sound pressure emission (at the operator position) < 70 dB.

- Sound Pressure $L_p < 70$ dB (A)
- At Operator Position
- Normal Operation
- According to ISO 7779:1988/EN 27779/1991 (Type Test)

Agilent Technologies on Internet

For the latest information on products and services visit our worldwide web site on the Internet at:

<http://www.agilent.com/chem>

A

accessory kit, 13, 49, 69
Agilent on internet, 89
algae growth, 32
ambient non-operating temperature, 11
ambient operating temperature, 11
analog output, 80
APG remote connector, 16
AUX output, 16
auxiliary cable, 41, 72

B

bench space, 10
bottle, 18
bottle-head assembly, 18
busy condition, 35

C

cable, 70
 auxiliary, 12, 41, 72
 CAN, 16
 GPIB, 16
 interface, 16
 power, 12, 37, 50
 remote, 12, 36, 70, 71
CAN cable, 16
changing solvents, 29
ChemStation, 16
cleaning the instrument, 48
connecting tube, 13
control assembly, 60
control circuit, 24
cover, 66

D

dead volume, 14
delay volume, 14
delivery checklist, 12
dimensions, 11

E

electronics
 how does it work, 74
electrostatic discharge (ESD), 47
environment, 10, 11
error condition, 35
error state, 39
ESD Strap, 49

exchanging

 control assembly, 60
 sensor assembly, 60
 solenoid valve, 59
 status light pipe, 53
 vacuum chamber, 55
 vacuum pump, 57

F

flow connections, 18
flow rate, 80
frequency range, 11
front of the vacuum degasser, 17
fuse, 10, 37

G

GPIB cable, 16

H

hardware symptoms, 36
highest injection precision, 25
highest retention time reproducibility, 25
humidity, 11

I

installation, 9, 16, 18
interface cable, 16
internal leak, 35
internet, 89
introduction to the degasser, 24

L

laboratory bench, 10
lamps
 off, degasser appears dead, 37
 status indicator is red, 39
 status indicator is yellow, vacuum pump not running, 40
 status indicator is yellow, vacuum pump runs continuously, 41
line frequency, 11
line voltage, 11

M

main cover, assembling, 52
materials in contact with solvent, 80
maximum flow rate, 80

maximum sensitivity, 25
mounting tool, 13, 19

N

non-operating altitude, 11
number of channels, 80

O

operating altitude, 11
operational hints, 29

P

parts
 accessory kit, 69
 cover, 66
 damaged, 12
 degasser, 64
 light pipes, 68
 missing, 12
 sheet metal kit, 67
performance specifications, 80
pH range, 80
power cable, 37, 50
power consumption, 11
power cord, 10
power light pipe, 68
power supply, 10
power supply lamp, 35
power switch, 16
power-input socket, 10
pressure sensor, 24
pressure sensor readings, 16, 41
priming
 with a pump, 29, 30
 with a syringe, 29
principle of operation, 24

R

ready condition, 35
rear of the vacuum degasser, 17
remote cable, 36, 70
remote cables, 71

S

screwdriver pozidriv #1, 50, 55
screwdriver pozidriv#1, 53
sensor assembly, 60
sheet metal kit, 67

shipping container, 12
site requirements, 10
snap fastener, 18
solenoid valve, 59
solvent bottle, 18
solvent cabinet, 18, 50
solvent filters
 checking, 32
 cleaning, 32
 prevent blocking, 32
solvent information, 26
solvent outlet tubes, 18
specification
 performance specifications, 80
 physical, 11
stack configuration, 14
status indicator, 34, 39, 40, 41
status light pipe, 53, 68
syringe, 13, 18
syringe adapter, 13, 21, 30

T

tool, 19
 mounting tool, 19
top cover, removing and refitting, 50
transportation, 21

V

vacuum chamber, 55
vacuum pump, 24, 57
voltage range, 11
voltage selector, 10
volume per channel, 80

W

wall socket, 10
warranty
 responsibility of Agilent Technologies, 84
 services, 84
waste tube, 13
weight, 11
when to use a degasser, 28

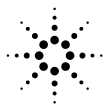

In This Book

This manual contains technical reference information about the Agilent 1100 Series micro vacuum degasser. The manual describes the following:

- installation,
- optimizing performance,
- troubleshooting,
- repairing,
- parts and materials,
- theory of operation, and
- specifications.

