

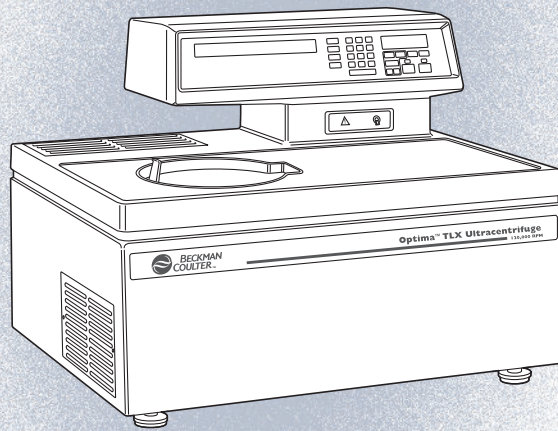

Optima™ TLX Preparative Ultracentrifuge



Instruction Manual

Symbol Symbol Symbole Símbolo	Simbolo 記号 符号 Title / Titel / Titre / Titolo / Titolo / 名称 / 名称
	Dangerous voltage Gefährliche elektrische Spannung Courant haute tension Voltaje peligroso Pericolo: alta tensione 危険電圧 危险电压
	Attention, consult accompanying documents Achtung! Begleitpapiere beachten! Attention, consulter les documents joints Atención, consulte los documentos adjuntos Attenzione: consultare le informazioni allegate 注意、添付資料を参照のこと 注意，请参阅附带的文件
	On (power) Ein (Netzverbindung) Marche (mise sous tension) Encendido Acceso (sotto tensione) 入（電源） 开（电源）
	Off (power) Aus (Netzverbindung) Arrêt (mise hors tension) Apagado Spento (fuori tensione) 切（電源） 关（电源）
	Protective earth (ground) Schutzleiteranschluß Liaison à la terre Puesta a tierra de protección Collegamento di protezione a terra 保護アース（接地） 保护接地
	Earth (ground) Erde Terre Tierra Scarica a terra アース（接地） 接地



SAFETY NOTICE

This safety notice summarizes information basic to the safe operation of the equipment described in this manual. The international symbol displayed above is a reminder that all safety instructions should be read and understood before installation, operation, maintenance, or repair of this centrifuge. When you see the symbol on other pages, pay special attention to the safety information presented. Observance of safety precautions will also help to avoid actions that could damage or adversely affect the performance of the centrifuge.

Safety During Installation and/or Maintenance

This ultracentrifuge is designed to be installed by a Beckman Coulter Field Service representative. Installation by anyone other than authorized Beckman Coulter personnel invalidates any warranty covering the instrument.

This ultracentrifuge weighs 81 kg (178 lb). Do not attempt to lift or move it without assistance.

Any servicing of this equipment that requires removal of any covers can expose parts which involve the risk of electric shock or personal injury. Make sure that the power switch is off and the centrifuge is disconnected from the main power source, and refer such servicing to qualified personnel.

Do not replace any ultracentrifuge components with parts not specified for use on this instrument.

Electrical Safety

To reduce the risk of electrical shock, this equipment uses a three-wire electrical cord and plug to connect the ultracentrifuge to earth-ground. To preserve this safety feature:

- Make sure that the matching wall outlet receptacle is properly wired and earth-grounded. Check that the line voltage agrees with the voltage listed on the name-rating plate affixed to the centrifuge.
- Never use a three-to-two wire plug adapter.
- Never use a two-wire extension cord or a two-wire non-grounding type of multiple-outlet receptacle strip.

Do not place containers holding liquid on or near the chamber door. If they spill, liquid may get into the centrifuge and damage electrical or mechanical components.

Safety Against Risk of Fire

Fuses protect certain electrical circuits within this instrument against overcurrent conditions. For continued protection against the risk of fire, replace only with the same type and rating specified.

This centrifuge is not designed for use with materials capable of developing flammable or explosive vapors. Do not centrifuge such materials (such as chloroform or ethyl alcohol) in this centrifuge nor handle or store them within the required 30-cm (1-ft) area surrounding the centrifuge.

Mechanical Safety

For safe operation of the equipment, observe the following:

- Use only the rotors and accessories designed for use in this centrifuge.
- Do not exceed the maximum rated speed of the rotor in use.
- Do not lift or move the centrifuge while the rotor is spinning.
- NEVER attempt to slow or stop the rotor by hand.
- NEVER attempt to override the door interlock system while the rotor is spinning.
- In the event of a power failure, do not attempt to retrieve the sample from the ultracentrifuge for at least 1 hour. Then follow the instructions for sample recovery in Section 4, TROUBLESHOOTING.

Chemical and Biological Safety

Normal operation may involve the use of solutions and test samples that are pathogenic, toxic, or radioactive. Such materials should not be used in this centrifuge, however, unless *all necessary safety precautions are taken*.

- Observe all cautionary information printed on the original solution containers prior to their use.
- Handle body fluids with care because they can transmit disease. No known test offers complete assurance that they are free of micro-organisms. Some of the most virulent—Hepatitis (B and C) and HIV (I–V) viruses, atypical mycobacteria, and certain systemic fungi—further emphasize the need for aerosol protection. Handle other infectious samples according to good laboratory procedures and methods to prevent spread of disease. Because spills may generate aerosols, observe proper safety precautions for aerosol containment. Do not run toxic, pathogenic, or radioactive materials in this centrifuge without taking appropriate safety precautions. Biosafe containment should be used when Risk Group II materials (as identified in the World Health Organization *Laboratory Biosafety Manual*) are handled; materials of a higher group require more than one level of protection.
- Dispose of all waste solutions according to appropriate environmental health and safety guidelines.

It is your responsibility to decontaminate the centrifuge and accessories before requesting service by Beckman Coulter.

Optima™ TLX Preparative Ultracentrifuge

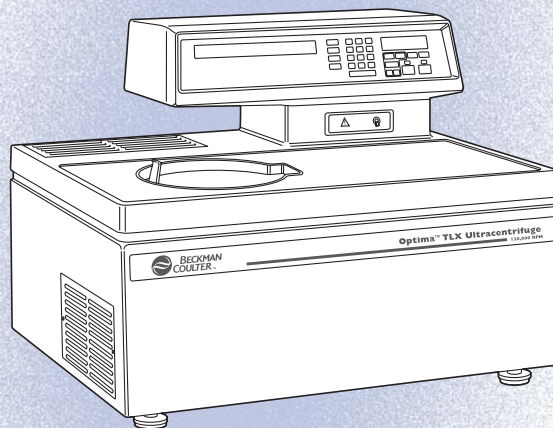

Instruction Manual

CE



	Page
INTRODUCTION	
<i>Certification</i>	vii
<i>Scope of Manual</i>	vii
<i>Conventions</i>	viii
<i>Notes, Cautions, and Warnings</i>	viii
<i>Typographic Conventions</i>	ix
<i>CFC-Free Centrifugation</i>	ix
<i>Radio Interference</i>	x
<i>Canadian Regulations</i>	x
<i>Recycling Label</i>	x
SECTION 1: DESCRIPTION	
Description	1-1
Rotor Chamber	1-2
Vacuum System	1-2
Temperature Sensing and Control	1-3
Drive	1-3
Controls and Indicators	1-4
Power Switch	1-4
Control Panel	1-4
Safety Features	1-8
Door	1-8
Barrier Ring	1-9
Imbalance Detector	1-9
Overspeed and Rotor Identification System	1-9
Name Rating Plate	1-9
Specifications	1-10
Available Rotors	1-11
SECTION 2: PREINSTALLATION REQUIREMENTS	
Space Requirements	2-1
Electrical Requirements	2-2

SECTION 3: OPERATION

Summary of Optima TLX Run Procedures	3-2
Programmed Run	3-2
Manual Run	3-3
Preparation	3-3
Installing the Rotor	3-4
Pre-Run Cooling or Warming	3-5
Manual Operation	3-6
Entering Run Speed	3-6
Entering Run Time	3-7
Entering Run Temperature	3-8
Entering Acceleration and Deceleration Rates	3-8
Starting a Run	3-10
Programmed Operation	3-11
Creating a New Program	3-11
Starting a Programmed Run	3-12
Recalling, Changing, or Deleting a Program	3-13

SECTION 4: TROUBLESHOOTING

User Messages	4-1
Retrieving Your Sample in Case of Power Failure	4-4
Circuit Breaker	4-7

SECTION 5: MAINTENANCE

Instrument Care	5-1
Vacuum System	5-2
Drive Hub	5-3
Air-Intake and Exhaust Louvers	5-3
Cleaning	5-3
Decontamination	5-3
Sterilization and Disinfection	5-4
Storage and Transportation	5-4
Supply List	5-5
Replacement Parts	5-5
Supplies	5-5

Warranty

Illustrations and Tables

	Page
Figure 1-1. The Optima TLX Ultracentrifuge	1-1
Figure 1-2. Temperature Control Diagram	1-3
Figure 1-3. Control Panel	1-4
Figure 2-1. Dimensions of the Optima TLX Ultracentrifuge	2-2
Figure 4-1. Location of User Messages on the Control Panel	4-2
Figure 4-2. Removing the Top Cover of the Instrument.	4-5
Figure 4-3. Door Lock System	4-6
Table 1-1. Available Rotors.	1-11
Table 3-1. Acceleration and Deceleration Rates	3-9
Table 4-1. User Message Chart	4-2

CERTIFICATION

To ensure full system quality, Beckman Coulter Optima™ TLX ultracentrifuges are manufactured in a registered ISO 9001 facility. They have been designed and tested to be compliant (when used with Beckman Coulter rotors) with the laboratory equipment requirements of applicable regulatory agencies. Declarations of conformity and certificates of compliance are available at www.beckmancoulter.com.

SCOPE OF MANUAL

This manual is designed to familiarize you with the Beckman Coulter Optima™ TLX ultracentrifuge, its functions, specifications, operation, and routine operator care and maintenance. We recommend that you read this entire manual, especially the SAFETY NOTICE and all safety-related information, before operating the ultracentrifuge or performing instrument maintenance.

- Section 1 contains system specifications and a brief physical and functional description of the ultracentrifuge, including the operating controls and indicators.
- Section 2 provides information about space and power requirements for installing and connecting the ultracentrifuge.
- Section 3 contains ultracentrifuge operating procedures.
- Section 4 lists possible malfunctions, together with probable causes and suggested corrective actions.
- Section 5 contains procedures for routine operator care and maintenance, as well as a brief list of supplies and replacement parts.

 **NOTE**

If the ultracentrifuge is used in a manner other than specified in this manual, the safety and performance of this equipment could be impaired. Further, the use of any equipment other than that recommended by Beckman Coulter has not been evaluated for safety. Use of any equipment not specifically recommended in this manual and/or the applicable rotor manual is the sole responsibility of the user.

CONVENTIONS

Certain symbols are used in this manual to call out safety-related and other important information. These international symbols may also be displayed on the centrifuge and are reproduced and described below and on the inside of the front cover.

NOTES, CAUTIONS, AND WARNINGS

 **NOTE**

Used to call attention to important information that should be followed during installation, use, or servicing of this equipment.



CAUTION

Used to indicate a potentially hazardous situation which, if not avoided, may result in minor or moderate injury and/or mechanical damage. It is also used to alert against unsafe practices.

**WARNING**

Used whenever an action or condition may potentially cause personal injury or loss of life. Mechanical damage may also result.

**WARNING**

Indicates high voltage or risk of electric shock. Refer servicing of all areas displaying either symbol to service personnel.

TYPOGRAPHIC CONVENTIONS

Certain typographic conventions are used throughout this manual to distinguish names of user interface components, such as keys and displays.

- *Keynames* (for example, **[START]** or **[PROG]**) appear in capital letters within brackets. (The **[ce]** key is not in capitals.)
- *Display names* (for example, **SPEED rpm** or **TIME hr:min**) appear in bold type.

CFC-FREE CENTRIFUGATION



To ensure minimal environmental impact, no CFCs are used in the manufacture or operation of the Optima TLX ultracentrifuge.

RADIO INTERFERENCE

This equipment has been tested and found to comply with the limits for a Class A digital device, pursuant to Part 15 of FCC Rules. These limits are designed to provide reasonable protection against harmful interference when the equipment is operated in a commercial environment. This equipment generates, uses, and can radiate radio frequency energy and, if not installed and used in accordance with this instruction manual, may cause interference to radio communications. Operation of this equipment in a residential area is likely to cause interference, in which case the user will be required to correct the interference at his own expense.

CANADIAN REGULATIONS

This equipment does not exceed the Class A limits for radio noise emissions from digital apparatus as set out in the radio interference regulations of the Canadian Department of Communications.

Le présent appareil numérique n'émet pas de bruits radioélectriques dépassant les limites applicables aux appareils numériques de Classe A prescrites dans le règlement sur le brouillage radioélectrique édicté par le Ministère des Communications du Canada.

RECYCLING LABEL



Note: On the instrument, the triangle background is yellow rather than gray.

This symbol is required in accordance with the Waste Electrical and Electronic Equipment (WEEE) Directive of the European Union. The presence of this marking on the product indicates:

- 1) the device was put on the European market after August 23, 2005 and
- 2) the device is not to be disposed via the municipal waste collection system of any member state of the European Union.

It is very important that customers understand and follow all laws regarding the proper decontamination and safe disposal of electrical equipment. For Beckman Coulter products bearing this label please contact your dealer or local Beckman Coulter office for details on the take back program that will facilitate the proper collection, treatment, recovery, recycling and safe disposal of the device.



DESCRIPTION

The Optima TLX (see Figure 1-1) microprocessor-controlled tabletop ultracentrifuge generates high centrifugal forces for a variety of high-speed applications. The instrument design features a variable-frequency induction drive, thermoelectric temperature control system, self-purging vacuum system, rotor overspeed identification system, program memory that can contain up to ten five-step programs, and a choice of acceleration and deceleration rates.

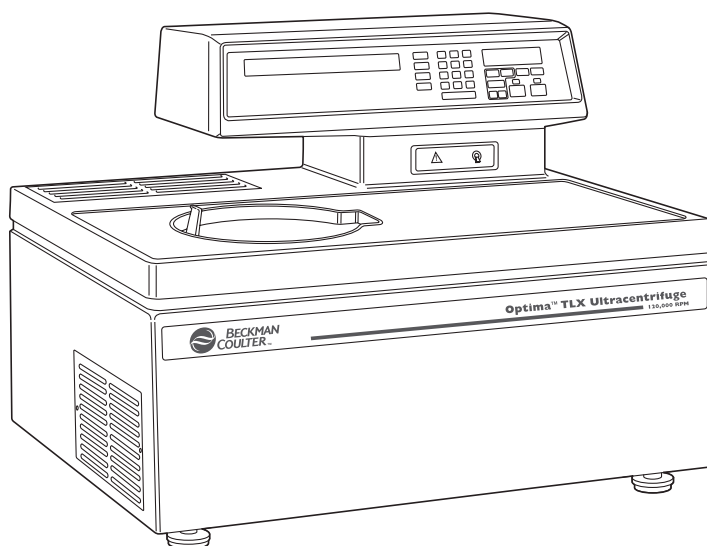

Figure 1-1. The Optima TLX Ultracentrifuge

Manual and programmed operation are available.

- In manual operation, you enter the individual run parameters before beginning each run.
- In programmed operation, you can duplicate runs quickly and accurately by selecting one of ten programs previously entered into the program memory. Each program can contain up to five steps.

User messages and/or audible signals are provided to alert you to conditions that may need attention.

ROTOR CHAMBER

The aluminum chamber is coated with a chemical-resistant epoxy finish to resist corrosion. The rotor drive hub and speed sensors are visible in the bottom of the chamber.

VACUUM SYSTEM

A diffusion pump, in series with a mechanical vacuum pump, reduces chamber pressure to below 10 microns (1.34 Pa). The vacuum pump starts automatically when the power is turned on and the door is closed. The diffusion pump is automatically activated when chamber pressure reaches about 500 microns. When the instrument is on and the door closed, a self-purging system continuously removes moisture from the vacuum system.

The **VAC** message appears on the control panel any time the power is on and the vacuum is above 500 microns. It also appears if a chamber pressure of 10 microns or less is not reached after 45 minutes. At speed over 5000 rpm, a rise in the vacuum level to over 500 microns will cause the message to flash and the instrument to decelerate to 5000 rpm until the vacuum level goes below 500 microns. The instrument will then accelerate to the set speed. If the vacuum remains above 500 microns for more than 20 minutes, the instrument will issue a **VAC** diagnostic and brake to a stop.

The vacuum is released when the [**DOOR**] key is pressed while the rotor is at rest. If you decide not to open the door after pressing the key, the vacuum system will automatically start again after 12 to 14 seconds.

TEMPERATURE SENSING AND CONTROL

The solid-state thermoelectric temperature control system uses only forced air—no coolant is required. With the power on, the temperature control system is activated when the door is closed and the vacuum system comes on. Run temperature can be set between 0 and 40°C. If no set temperature is entered, the instrument automatically selects the last entered temperature. (For the first run of a new instrument, 25°C is the default operating temperature.)

A sensor in the rotor chamber continuously monitors chamber temperature. The microprocessor calculates the required chamber temperature to maintain the selected rotor temperature. Peak-to-peak fluctuations of rotor temperature (after reaching thermoequilibrium) will be within 0.1°C (see Figure 1-2).

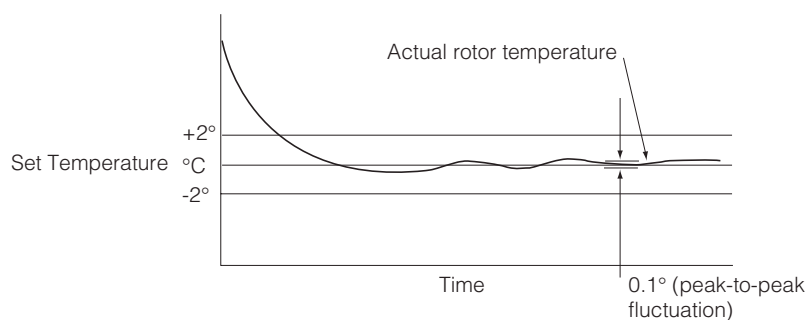

Figure 1-2. Temperature Control Diagram

DRIVE

The air-cooled direct-drive induction motor is frequency controlled, with no gears or brushes. In addition, the drive does not require an oil vacuum seal or external oil reservoir. Externally cooled by forced air and internally cooled by oil, the drive delivers ultra-smooth, quiet performance.

CONTROLS AND INDICATORS

POWER SWITCH

The power switch controls electrical power to the ultracentrifuge. It is also a circuit breaker that will trip to cut off power in the event of a power overload. The power switch must be turned on before the chamber door can be opened.

CONTROL PANEL

The control panel (see Figure 1-3) is used to enter run parameters via touch keys and a keypad, and to display run parameters and program information. A beep sounds when a key has been pressed and the input accepted.

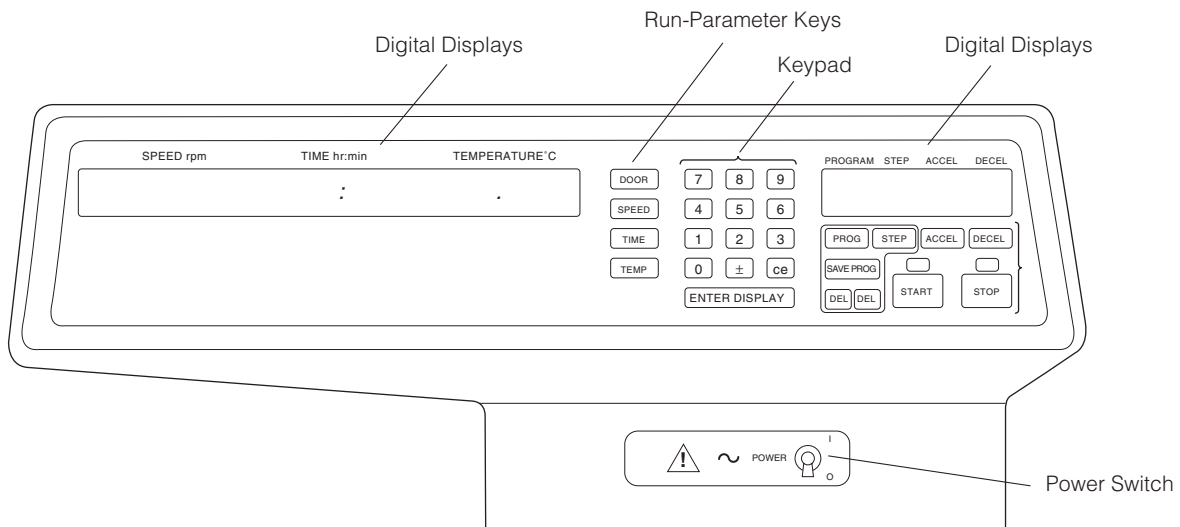

Figure 1-3. Control Panel

Digital Displays



The displays serve a dual purpose.

- During a run, they show the actual (real-time) operating conditions.
- When the run parameters are being entered, they show the set values selected. In manual operation, these set values are retained in memory until new values are entered. They can be recalled by pressing [ENTER/DISPLAY]. After 5 seconds, the displays return to actual conditions.

SPEED rpm

Indicates rotor speed in revolutions per minute (rpm). Speeds between 0 and 5000 rpm are shown in increments of 10; speeds above 5000 rpm are shown in increments of 100.

TIME hr:min

During centrifugation, the display starts counting down when the rotor begins to spin.

- Manual operation—indicates time remaining in the run.
- Programmed operation—indicates time remaining in the step.

The run automatically ends when the set time reaches zero (a tone sounds when the rotor stops spinning). If a malfunction shuts down the ultracentrifuge during a run, the time counting stops and the time remaining when the run stopped remains in the display. By comparing this time with the original set time, you can determine when the run ended.

TEMPERATURE °C

Indicates rotor temperature in degrees C at thermoequilibrium. The temperature is displayed to a tenth of a degree and is within ± 2 degrees of the set temperature (after equilibration).

PROGRAM

- During setup—when the [PROG] key is pressed a dash flashes in this display, indicating that a program number needs to be entered.
- During centrifugation—the number of the program being run is displayed.

STEP	<ul style="list-style-type: none">• During setup—when the [STEP] key is pressed a dash flashes in this display, indicating which step is being created or modified.• During centrifugation—the number of the step being run is displayed.
ACCEL	When the [ACCEL] key is pressed, a dash flashing in the display indicates that an acceleration rate can be entered. (Ten acceleration rates are available to protect specific gradient and sample-to-gradient interfaces.) If no number is entered, the instrument accelerates at the maximum rate and the display remains blank.
DECEL	When the [DECEL] key is pressed, a dash flashing in the display indicates that a number representing the selected deceleration rate can be entered. (Eleven deceleration rates are available to maintain optimum separation.) If no number is entered, the instrument decelerates at the maximum rate and the display remains blank.

User Messages

User messages appear on the control panel to assist you in properly operating the instrument or to alert you to conditions requiring attention. These user messages are described in detail, together with recommended actions, in Section 4, TROUBLESHOOTING.

Run-Parameter Keys

Run-parameter keys are used to enter specific run information as follows.

[DOOR]	Unlocks the door and vents the chamber. (The instrument will not accept this command if the rotor is spinning.)
[SPEED]	Pressed to enter run speed (using the keypad). When entering the set speed, the last three digits in the display are fixed as zeros and cannot be changed.
[TIME]	Pressed to enter run time (using the keypad), up to 99 hours and 59 minutes.

[TEMP]	Pressed to enter run temperature (using the keypad), from 0 to 40°C. If a new temperature is not entered, the instrument automatically uses the last temperature entered. (Default temperature for a new ultracentrifuge is 25°C.)
Keypad	The keypad is used to enter numerical run parameters, to enter or recall a program number, and to select acceleration and/or deceleration rates. In addition to keys 0 through 9, the keypad includes a [ce] (clear entry) key and an [ENTER/DISPLAY] key.
[ACCEL]	The acceleration time is the time it takes a rotor to reach 5000 rpm from 0 rpm. At 5000 rpm, the rotor then accelerates at maximum speed until it reaches set speed. The [ACCEL] key is used to select one of the ten acceleration rates (see Table 3-1 in Section 3) provided to protect the gradient and sample to-gradient interface.
[DECEL]	The deceleration time is the time it takes a rotor to decelerate from 5000 to 0 rpm. From set speed to 5000 rpm, the rotor decelerates with full dynamic braking. The [DECEL] key is used to select one of eleven deceleration rates (see Table 3-1 in Section 3) provided to maintain optimum separation.
[START]	To begin a run, [ENTER/DISPLAY] must always be the last key pressed before pressing [START]. Further, you must press [START] while the set values are being displayed. If you wait beyond this time, the [START] key will not activate, and you will need to press [ENTER/DISPLAY] and [START] again. The green light above the [START] key flashes until the vacuum reaches 500 microns. At this point, the rotor begins to spin and the light remains on until the end of the run.
[STOP]	Can be pressed at any time to terminate a run. The green light above the key flashes while the rotor decelerates. An audio indicator sounds when the rotor comes to a complete stop.

NOTE

If you press [START] and then decide to open the chamber door, you must press [STOP] before pressing [DOOR], even if the rotor is at rest.

Program Keys

The internal memory can store up to ten programs, each containing up to five sets of run parameters (each set is referred to as a step). Programs are created using the keys below; once created, each can be recalled by pressing keypad numbers. Programs will be retained in memory even if the power is turned off.

- [PROG] A toggle switch used to enter into and exit out of the program mode to create or modify programs. When the key is pressed, a dash flashes in the display and the program number can be selected using the keypad.
- [STEP] Selects a step in a program to be created or modified. When the key is pressed, a “1” appears in the display. The values for that step are displayed for 5 seconds, then actual operating conditions reappear. Each time [STEP] is pressed, the number increases by one digit. Up to five steps can be created in a program.
- [SAVE PROG] Saves the program in memory after program run parameters have been entered.
- [DEL] [DEL] These two keys must be pressed simultaneously to clear a program and reset all program steps to default values. The double keys are designed to help prevent accidental deletion of a program.

SAFETY FEATURES

The Optima TLX ultracentrifuge has been designed and tested to operate safely indoors at altitudes up to 2 000 m (6 562 ft).

DOOR

The steel chamber door has an electromechanical door-locking mechanism to prevent operator contact with a spinning rotor. When the door is closed it locks automatically. It can be unlocked only by pressing [DOOR], and opened only when the power is on and the rotor is at rest. If there is a power failure, the door lock can be manually tripped for sample recovery (see Section 4, TROUBLESHOOTING).

BARRIER RING

A 19-mm ($3/4$ -in.) structural steel armor ring acts as the primary barrier, surrounded by a 13-mm ($1/2$ -in.) steel secondary barrier ring to provide full protection for the operator.

IMBALANCE DETECTOR

An imbalance detector monitors the rotor during the run, causing automatic shutdown if rotor loads are severely out of balance. At low speeds, an incorrectly loaded rotor can cause an imbalance. Rotor instability can also occur if the instrument is moved, or if it is not resting level on the table or bench (see Section 4, TROUBLESHOOTING).

OVERSPEED AND ROTOR IDENTIFICATION SYSTEM

The overspeed system, which includes magnetic speed sensors in the rotor chamber and magnets on the bottom of each rotor, continuously monitors the rotor during centrifugation. At 1000 rpm, the system identifies both the rotor type and maximum rotor speed and compares the set speed with the rotor's maximum permitted speed. If the set speed is greater than the maximum permitted speed, the **SPEED rpm** display begins to flash rapidly and the rotor decelerates to a stop. The error must be cleared and an appropriate speed entered before the run can be continued or restarted. Throughout the run, checks are made to ensure that the rotor does not exceed set speed. If a speed-related problem occurs, the user message **SPD** will appear.

NAME RATING PLATE

A name rating plate is affixed to the rear of the instrument. Always mention the serial number and model number when contacting Beckman Coulter regarding your Optima TLX ultracentrifuge.

SPECIFICATIONS

Only values with tolerances or limits are guaranteed data. Values without tolerances are informative data, without guarantee.

Speed

Set speed	5 000 to 120 000 rpm in 1 000-rpm increments
Speed control	actual rotor speed, ± 50 rpm of set speed
Speed display	actual rotor speed in 100-rpm increments above 5 000 rpm and 10-rpm increments at speeds below 5 000 rpm

Time

Set time	to 99 hours 59 minutes
Time display	
Manual operation	indicates run time remaining
Programmed operation	time remaining in step

Temperature

Set temperature	2 to 40°C in 1° increments
Temperature control (after equilibration).	$\pm 2^\circ\text{C}$ of set temperature
Temperature display	actual rotor temperature in 0.1° increments
Ambient temperature range	15 to 35°C

Humidity restrictions. <95% (noncondensing)

Vacuum below 10 microns (1.34 Pa)

Acceleration 10 acceleration profiles—
9 slow rates from 0 to 5 000 rpm followed by
full acceleration to set speed; or maximum acceleration

Deceleration 11 deceleration profiles—10 slow rates
from 5 000 to 0 rpm, including coasting to a stop
without brake; or full dynamic braking from set speed

Dimensions

Width	73.7 cm (29 in.)
Depth	58.4 cm (23 in.)
Height.	53.3 cm (21 in.)

Weight 81 kg (178 lb)

Ventilation clearances (sides and rear) 7.6 cm (3.0 in.)

Finishes

Control panel	coated polycarbonate
Top surface	acrylic baking enamel
Other surfaces.	general purpose paint

Electrical requirements

100-V instrument	90–110 VAC, 12 A, 50/60 Hz
120-V instrument	100–130 VAC, 12 A, 50/60 Hz
220/240-V instrument	198–254 VAC, 6 A, 50 Hz

Electrical supply Class I

Maximum heat dissipation into room under

 steady-state conditions 1750 Btu/hr (0.5 kW)

Noise level 0.91 m (3 ft) in front of centrifuge <60 dBa

Installation (overvoltage) category II



Pollution degree. 2*

* Normally only nonconductive pollution occurs; occasionally, however, a temporary conductivity caused by condensation must be expected.

AVAILABLE ROTORS

All Beckman Coulter TL-series rotors can be used in the Optima TLX ultracentrifuge (see Table 1-1). The rotors are described in individual manuals that accompany each rotor. Information on rotors and accessories is also available in *Rotors and Tubes for Tabletop Preparative Ultracentrifuges* (TLR-IM, available on CD 369668) and in the *Ultracentrifuge Rotors, Tubes & Accessories* catalog (publication BR-8101, available at www.beckmancoulter.com).

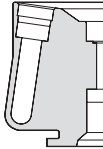
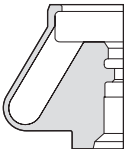
Table 1-1. Available Rotors

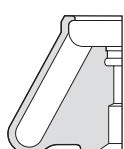
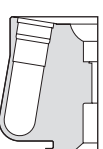
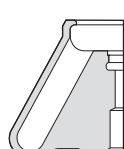
Rotor Profile and Description	Max RPM/ k factor*	Max RCF [†] ($\times g$) at r_{\max}	Number of Tubes \times Nominal Capacity	Rotor Manual Number
 TLN-120 Near Vertical Tube 8° Angle	120 000 7	585 000	8 \times 1.2 mL	TL-TB-017
 TLA-120.2 Fixed Angle 30° Angle	120 000 8	627 000	10 \times 2.0 mL	TL-TB-016
 TLA-120.1 Fixed Angle 30° Angle	120 000 8	627 000	14 \times 0.5 mL	TL-TB-015
 TLA-110 Fixed Angle 28° Angle	110 000 20	657 000	8 \times 5.1 mL	TL-TB-019
 TLN-100 Near Vertical Tube 9° Angle	100 000 14	450 000	8 \times 3.9 mL	TL-TB-013
 TLA-100.4 [‡] Fixed Angle 28° Angle	100 000 16	543 000	8 \times 5.1 mL	TL-TB-014

Continued —

Table 1-1. Available Rotors (continued)

Rotor Profile and Description	Max RPM/ k factor*	Max RCF† (× g) at r_{\max}	Number of Tubes × Nominal Capacity	Rotor Manual Number
 TLA-100.3 Fixed Angle 30° Angle	100 000 14	543 000	6 × 3.5 mL	TL-TB-011
 TLA-100.2 Fixed Angle 30° Angle	100 000 12	436 000	10 × 2.0 mL	TL-TB-005
 TLA-100.1‡ Fixed Angle 30° Angle	100 000 12	436 000	12 × 0.5 mL	TL-TB-004
 TLA-100 Fixed Angle 30° Angle	100 000 7	436 000	20 × 0.2 mL	TL-TB-003
 TLV-100 Vertical Tube 0° Angle	100 000 9	400 000	8 × 2.0 mL	TL-TB-007
 TLA-55 Fixed Angle 45° Angle	55 000 66	186 000	12 × 1.5 mL	TL-TB-020
 TLS-55 Swinging Bucket 90° Angle**	55 000 50	259 000	4 × 2.2 mL	TL-TB-006

Continued —

Table 1-1. Available Rotors (continued)

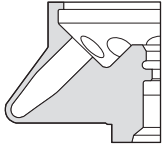
Rotor Profile and Description	Max RPM/ <i>k</i> factor*	Max RCF† (× <i>g</i>) at <i>r</i> _{max}	Number of Tubes × Nominal Capacity	Rotor Manual Number
 TLA-45‡ Fixed Angle 45° Angle	45 000 99	125 000	12 × 1.5 mL	TL-TB-012

*Maximum speeds are based on a solution density of 1.7 g/mL for all rotors. The *k* factors are calculated for all Beckman Coulter rotors (using the largest-volume tube) as a measure of the rotor's relative pelleting efficiency, in water, at 20°C.

† Relative Centrifugal Field (RCF) is the ratio of the centrifugal acceleration at a specified radius and speed ($r\omega^2$) to the standard acceleration of gravity (*g*) according to the following formula:

$$\text{RCF} = \frac{r\omega^2}{g}$$

where *r* is the radius in millimeters, ω is the angular velocity in radians per second ($2\pi \text{ RPM} / 60$), and *g* is the standard acceleration of gravity (9807 mm/s²). After substitution:

$$\text{RCF} = 1.12r \left(\frac{\text{RPM}}{1000} \right)^2$$

‡ No longer manufactured.

** At speed.

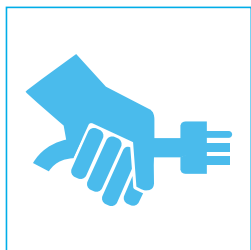

Preinstallation Requirements

Preinstallation requirements have been provided for your Optima TLX ultracentrifuge. The following information is included in case the instrument must be relocated.

NOTE

This ultracentrifuge is designed to be installed by a Beckman Coulter Field Service representative. Installation by anyone other than authorized Beckman Coulter personnel invalidates any warranty covering the instrument.

SPACE REQUIREMENTS



WARNING

Do not place the ultracentrifuge near areas containing flammable reagents or combustible fluids. Vapors from these materials could enter the centrifuge air system and be ignited by the motor. Maintain a 30-cm (1-ft) clearance envelope around the centrifuge while it is running. No persons or any hazardous materials should be within this clearance boundary while the centrifuge is operating except to change operating controls, if required.

If it is necessary to move the ultracentrifuge, maintain the following conditions.

If it is necessary to move the ultracentrifuge, maintain the following conditions.

- Select a location away from heat-producing laboratory equipment, with sufficient ventilation to allow for heat dissipation.
- Position the ultracentrifuge on a level surface, such as a sturdy table or laboratory bench that can support the weight of the centrifuge (81 kg/178 lb) and resist vibration. (We recommend placing the instrument at least 5.1 cm (2 in.) from the edge of the laboratory bench.)
- In addition to space for the ultracentrifuge itself (see Figure 2-1 for dimensions), allow 7.6-cm (3-in.) clearances at the sides and back to ensure sufficient air circulation. The ultracentrifuge must have adequate air ventilation to ensure compliance to local requirements for vapors produced during operation.
- Relative humidity should not exceed 95% (noncondensing).

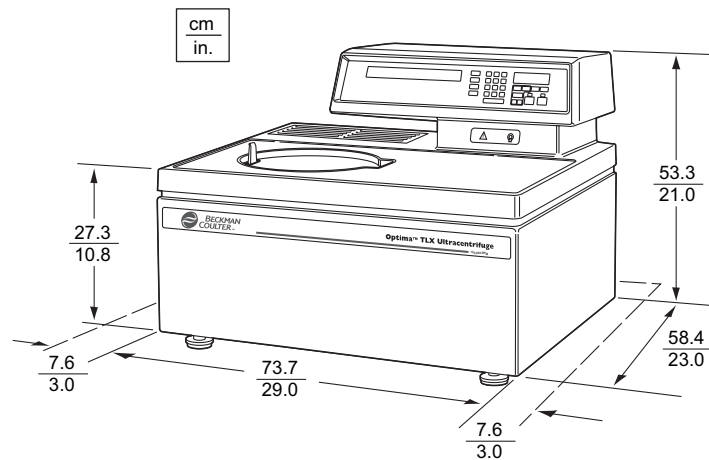

Figure 2-1. Dimensions of the Optima TLX Ultracentrifuge

ELECTRICAL REQUIREMENTS

100-V centrifuge	90–110 VAC, 12 A, 50/60 Hz
120-V centrifuge	100–130 VAC, 12 A, 50/60 Hz
220/240-V centrifuge.	198–254 VAC, 6 A, 50 Hz

To reduce the risk of electrical shock, this centrifuge uses a 1.8-m (6-ft) three-wire electrical cord, to be attached to the IEC 320/CEE-20 AC power connector at the rear of the instrument, and plug to connect the centrifuge to earth-ground. (A plug that meets your local electrical and safety requirements was supplied with the instrument. Contact your local Beckman Coulter office for specific information regarding local requirements.) To preserve this safety feature:

- Make sure that the matching wall outlet receptacle is properly wired and earth-grounded. Check that the line voltage agrees with the voltage listed on the name rating plate affixed to the centrifuge. Then plug in both ends of the centrifuge power cord.
- Never use a three-to-two wire plug adapter.
- Never use a two-wire extension cord or a two-wire non-grounding type of multiple-outlet receptacle strip.
- If there is any question about voltage, have a qualified service person measure it under load while the drive is operating.

To ensure safety the centrifuge should be wired to a remote emergency switch (preferably outside the room where the centrifuge is housed, or adjacent to the exit from that room), in order to disconnect the centrifuge from the main power source in case of a malfunction.

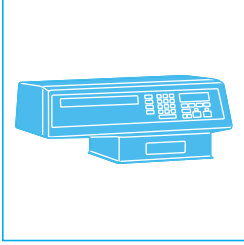

This section contains manual and programmed operating procedures. A summary is provided at the start of this section. If you are an experienced user of this ultracentrifuge, you can turn to the summary for a quick review of operating steps.



WARNING

Normal operation may involve the use of solutions and test samples that are pathogenic, toxic, or radioactive. Handle body fluids with care because they can transmit disease. No known test offers complete assurance that they are free of micro-organisms. Some of the most virulent—Hepatitis (B and C) and HIV (I–V) viruses, atypical mycobacteria, and certain systemic fungi—further emphasize the need for aerosol protection. Handle other infectious samples according to good laboratory procedures and methods to prevent spread of disease. Because spills may generate aerosols, observe proper safety precautions for aerosol containment. Do not run toxic, pathogenic, or radioactive materials in this centrifuge without taking appropriate safety precautions. Biosafe containment should be used when Risk Group II materials (as identified in the World Health Organization *Laboratory Biosafety Manual*) are handled; materials of a higher group require more than one level of protection.

**WARNING**

Do not use the ultracentrifuge in the vicinity of flammable liquids or vapors, and do not run such materials in the instrument. Do not lean on the instrument or place items on it while it is operating.

SUMMARY OF OPTIMA TLX RUN PROCEDURES

For runs at other than room temperature, refrigerate or warm the rotor beforehand for fast equilibration. For low-temperature runs, precool the system as described under Pre-Run Cooling or Warming, below.

PROGRAMMED RUN

1	POWER	Turn the POWER switch to ON (I).
2	[DOOR]	Press [DOOR] to unlock the chamber door; slide the door open.
3		Install the rotor according to the applicable rotor manual. <i>Be sure to lock it in place by pressing the plunger down until you hear a click.</i> Close the chamber door.
4	[PROG]	Press [PROG], then use the keypad to enter the required program number.
5	[ENTER/DISPLAY] [START]	Check that all parameters are correct and that the door is closed. Press [ENTER/DISPLAY], then press [START].
6	[STOP]	Wait for the last step in the program to end, or end the run by pressing [STOP].
7	[DOOR]	When the rotor stops (a tone sounds), press [DOOR] to unlock the chamber door; slide the door open to remove the rotor.

MANUAL RUN

1	POWER	Turn the POWER switch to ON (I).
2	[DOOR]	Press [DOOR] to unlock the chamber door; slide the door open.
3		Install the rotor according to the applicable rotor manual. <i>Be sure to lock it in place by pressing the plunger down until you hear a click.</i> Close the chamber door.
4	[SPEED]	Press [SPEED], then use the keypad to enter the run speed (5000 to 120 000 rpm).
5	[TIME]	Press [TIME], then use the keypad to enter the run time (to 99 hrs, 59 minutes).
6	[TEMP]	Press [TEMP], then use the keypad to enter the required run temperature (2 to 40°C).
7	[ACCEL]	Press [ACCEL], then use the keypad to enter the selected acceleration rate number, 1 to 9. (You can skip this step and accept the default acceleration rate, which is maximum acceleration.)
8	[DECEL]	Press [DECEL], then use the keypad to enter the selected deceleration rate number, 1 to 0. (You can skip this step and accept the default deceleration rate, which is maximum deceleration.)
9	[ENTER/DISPLAY] [START]	Check that all parameters are correct and that the door is closed. Press [ENTER/DISPLAY], then press [START].
10	[STOP]	Wait for the set time to count down to zero, or end the run by pressing [STOP].
11	[DOOR]	When the rotor stops (a tone sounds), press [DOOR] to unlock the chamber door; slide the door open to remove the rotor.

PREPARATION

Prepare the rotor for centrifugation as described in the applicable rotor manual.

INSTALLING THE ROTOR

The power must always be turned on before you can unlock and open the chamber door.

Action

1. Turn the POWER switch on. (To end a run for any reason, do not turn the POWER switch off; press [STOP] instead.)
2. Press [DOOR] to unlock the door and vent the chamber.
3. After the chamber has been vented, use the door handle to slide the door open.

Result

Indicator lights on the control panel light up.

The instrument will accept this command only when the rotor is at rest. You can hear a slight hissing sound when the chamber vents.

If you do not open the door after pressing [DOOR], the vacuum system will automatically restart after 8 seconds.

NOTE

To unlock the door after you have pressed [START] (even if the rotor is still at rest), press [STOP] and then [DOOR]. The DOOR message appears on the control panel and an intermittent beep will remind you when the door is open. To clear these signals, close the door. See TROUBLESHOOTING, Section 4, for instructions on opening the door in an emergency.



CAUTION

4. Install the rotor according to directions in the rotor manual. Ensure that the rotor is seated on the drive hub.

When installing a rotor on the drive hub, be sure to lock it in place by gently pressing the plunger in the rotor down until you hear a click. When you remove your finger, the plunger will remain depressed if it is properly engaged. If the plunger pops up, repeat the procedure, then try to lift the rotor to ensure that it is locked. It is very important to lock the rotor in place before beginning the run.

Action**Result**

-
- Close the chamber door. (To keep the chamber clean and dry, leave the door closed whenever possible.)

PRE-RUN COOLING OR WARMING

For fast temperature equilibration, cool or warm the rotor to the required temperature before the run. Also precool or warm the instrument as follows.

NOTE

This procedure can be programmed as the first step of a programmed run.

Action**Result**

-
- Press [TEMP].
 - Use the keypad to enter the required temperature.

The **TEMPERATURE °C** display flashes.

Entered temperature appears on the **TEMPERATURE °C** display. (If the entry is incorrect, press [ce], then enter the correct value.)

NOTE

The remaining steps (3 through 7) are required *only* if precooling or warming is the first step in a multi-step program. For a manual run, only steps 1 and 2 are required.

- Press [TIME].
- Use the keypad to enter time for the instrument to reach the set temperature (usually 15 to 20 minutes).

The **TIME hr:min** display flashes.

Entered time appears on the **TIME hr:min** display. (If the entry is incorrect, press [ce], then enter the correct value.)

<i>Action</i>	<i>Result</i>
5. Press [SPEED].	The SPEED rpm display flashes.
6. Use the keypad to enter 0 rpm.	A 0 appears on the SPEED rpm display.
7. Press [ENTER/DISPLAY] and [START].	The instrument will begin cooling.

MANUAL OPERATION

When a run-parameter key is pressed, the appropriate display flashes to indicate that a value can be entered. The display continues to flash until [**ENTER/DISPLAY**] or the next run-parameter key is pressed. If an unacceptable value is entered, the appropriate display flashes rapidly to indicate the error. The error must be cleared and an acceptable value entered.

ENTERING RUN SPEED

Run speed can be set between 5000 and 120 000 rpm. When entering set speed, the last three digits in the display are fixed as zeros and cannot be changed by keypad entries.

<i>Action</i>	<i>Result</i>
1. Press [SPEED].	The SPEED rpm display flashes.
2. Use the keypad to enter required speed.	Entered speed appears on the SPEED rpm display. (If the entry is incorrect, press [ce], then enter the correct value.)
3. Press the next run-parameter key or [ENTER/DISPLAY].	If you entered an unacceptable speed, such as a speed below 5000 rpm (other than 0 rpm), the SPEED rpm display will flash rapidly to indicate an operator error. (Press [ce] and enter an acceptable value, then press the next run- parameter key or [ENTER/DISPLAY] again.)

You can change the set speed at any time by repeating steps 1 through 3. The rotor will accelerate or decelerate to the new speed.

NOTE

At 1000 rpm, the instrument identifies the rotor and checks its maximum allowable speed. If set speed is greater than the rotor's maximum allowable speed, the **SPEED rpm** display will flash rapidly and the rotor will decelerate to a stop. To clear the error, press [**ce**] and enter an acceptable run speed. Press [**ENTER/DISPLAY**] and [**START**] again to restart the run. If certain speed-related malfunctions occur during centrifugation, there will be a 20-minute delay before the user message **SPD** can be cleared and the door unlocked. This is to ensure that the rotor has come to a complete stop. Refer to Section 4, TROUBLESHOOTING.

ENTERING RUN TIME

Run time can be set for up to 99 hours and 59 minutes. The **TIME hr:min** display begins counting down when the rotor starts to spin. The run automatically terminates when the set time reaches zero, and a tone sounds when the rotor has stopped.

Action

1. Press [**TIME**].
2. Use the keypad to enter required time.
3. Press the next run-parameter key or [**ENTER/DISPLAY**].

Result

The **TIME hr:min** display flashes.

Entered time appears on the **TIME hr:min** display. (If the entry is incorrect, press [**ce**], then enter the correct value.)

If you entered a number over 59 minutes, the instrument automatically recalculates the time in hours and minutes.

ENTERING RUN TEMPERATURE

Run temperature can be set from 2 to 40°C. If no value is entered, the instrument automatically selects the last entered temperature. (If all previous entries have been cleared, 25°C is selected as the operating temperature.)

Action

1. Press [**TEMP**].
2. Use the keypad to enter required temperature.
3. Press the next run-parameter key or [**ENTER/DISPLAY**].

Result

The **TEMPERATURE** °C display flashes.

Entered temperature appears on the **TEMPERATURE** °C display. (If the entry is incorrect, press [**ce**], then enter the correct value.)

NOTE

If the rotor temperature rises more than 3°C above the set temperature for more than 40 minutes, the user message **TEMP** will flash on the control panel. If a run is in progress, the rotor will decelerate to a stop (see TROUBLE-SHOOTING, Section 4).

ENTERING ACCELERATION AND DECELERATION RATES

The instrument provides a choice of ten acceleration rates and eleven deceleration rates to protect the gradient and sample-to-gradient interface. Table 3-1 lists these rates by keypad number. The acceleration time is the time it takes a rotor to reach 5000 rpm from rest. At 5000 rpm, maximum acceleration takes over until the rotor reaches set speed. The deceleration time is the time it takes a rotor to decelerate from 5000 rpm to rest; from set speed to 5000 rpm, the rotor decelerates with full dynamic braking. If no rate is selected, the instrument automatically accelerates and decelerates at maximum rate and the **ACCEL** and **DECEL** displays remain blank.

Table 3-1. Acceleration and Deceleration Rates

Keypad Number	ACCEL Time from 0 to 5000 rpm (minutes)	DECEL Time from 5000 to 0 rpm (minutes)
(blank)	1/4*	1/4*
1	1/2	1
2	1	1 1/2
3	1 1/2	2
4	2	2 1/2
5	2 1/2	3
6	3	4
7	3 1/2	6
8	4	8
9	5	10
0	N/A	coasting stop from set speed without brake

*Maximum rate. If no keypad number is selected, the rotor will accelerate and/or decelerate at maximum rates. The display(s) will remain blank.

Action

1. Press [**ACCEL**].
2. Press the keypad number for the required acceleration rate.
3. Press the next run-parameter key or [**ENTER/DISPLAY**].
4. Press [**DECEL**].
5. Press the keypad number for the required deceleration rate.
6. To clear the **DECEL** display entirely, press [**DECEL**], [**ce**], and another run-parameter key or [**ENTER/DISPLAY**].

Result

- The **ACCEL** display flashes.
- Entered number appears on the **ACCEL** display. (If the entry is incorrect, press [**ce**], then enter the correct value.)
- To clear the **ACCEL** display entirely, press [**ACCEL**], [**ce**], and another run-parameter key or [**ENTER/DISPLAY**].
- The **DECEL** display flashes.
- Entered number appears on the **DECEL** display. (If the entry is incorrect, press [**ce**], then enter the correct value.)

STARTING A RUN

Action

1. Press [ENTER/DISPLAY] and [START].

Result

The green light above the [START] key flashes and the rotor begins to spin.

NOTE

To begin a run, [ENTER/DISPLAY] must always be the last key pressed before pressing [START]. Further, you must press [START] while the set values are being displayed. If you wait beyond this time, the [START] key will not activate. If this happens, press [ENTER/DISPLAY] and [START] again to begin the run.

If an unacceptable value was entered, the run will not begin when [ENTER/DISPLAY] and [START] are pressed. Check each display and make any necessary corrections or additions. Press [ENTER/DISPLAY] and [START] again to begin the run.

The run will end automatically when the **TIME hr:min** display counts down to zero. (Press [STOP] to terminate a run for any reason.) The green light above the [STOP] key will flash while the rotor decelerates. A tone will sound when the rotor has come to a complete stop.

NOTE

If you pressed [ENTER/DISPLAY] and [START] and then decide that you want to open the chamber door, you must press [STOP] before pressing [DOOR], even if the rotor is at rest.

2. After the rotor has stopped, press [DOOR].

The door is unlocked and the chamber vented.

NOTE

To repeat this run, press [ENTER/DISPLAY] and [START]. There is no need to reenter run parameters until you wish to make a change.

3. Remove the rotor. Keep the chamber door closed between runs.

PROGRAMMED OPERATION

The instrument internal memory can store up to ten programs which can be recalled by keypad numbers 0 through 9. Each program can contain up to five steps (that is, up to five sets of run parameters). Programs are retained in memory even if the power is turned off. Procedures for entering run parameters are the same for programmed operation as those described above for manual operation, with the following exceptions:

- The [ENTER/DISPLAY] key is not used to enter keypad numbers.
- Programs cannot be cleared using the [ce] key; the [DEL] [DEL] keys must be pressed simultaneously to clear an entire program and reset all steps to default values.

CREATING A NEW PROGRAM

Action

Result

- | | |
|---|---|
| 1. Press [PROG]. | A dash flashes in the PROGRAM display. |
| 2. Select a keypad number for the program. | The selected number appears in the PROGRAM display; a “1” (indicating step 1) appears in the STEP display. |
| 3. Enter run parameters (speed, time, temperature, acceleration/deceleration rate settings) for step 1. | If you entered an unacceptable parameter, applicable display will flash rapidly to indicate an operator error. (Press [ce] and enter an acceptable value, then press the next run-parameter key.) |
| 4. When all parameters for step 1 are entered, press [STEP]. | A “2” (indicating step 2) appears in the STEP display. |
| 5. Repeat Steps 2 through 4 to enter parameters for up to five steps for a complete run. | |
| 6. Press [SAVE PROG]. | All the steps making up the program are saved into memory. |

NOTE

Record the program parameters on the Program Library chart (TLX-TB-004).

STARTING A PROGRAMMED RUN

Action

1. Press [**PROG**].
2. Use the keypad to enter the number of the program.
3. To recall another step, press [**STEP**] repeatedly until the appropriate step number appears.
4. Press [**ENTER/DISPLAY**] and [**START**] to begin the programmed run (or press [**PROG**] to exit program mode and return to manual operation).

Result

- A dash flashes in the **PROGRAM** display.
- The number you selected will appear in the **PROGRAM** display; a 1 (indicating step 1) will appear in the **STEP** display.
- Run parameters for that step will be displayed for 5 seconds. (To make changes, see Changing a Program, below.)
- The run starts with step 1 and continues through all saved steps. The green light above the [**START**] key flashes and the rotor begins to spin.

NOTE

To begin a run, [**ENTER/DISPLAY**] must always be the last key pressed before pressing [**START**]. Further, you must press [**START**] while the set values are being displayed. If you wait beyond this time, the [**START**] key will not activate. If this happens, press [**ENTER/DISPLAY**] and [**START**] again to begin the run.

If an unacceptable value was entered, the run will not begin when [**ENTER/DISPLAY**] and [**START**] are pressed. Check each display and make any necessary corrections or additions. Press [**ENTER/DISPLAY**] and [**START**] again to begin the run.

The run will end automatically when the TIME hr:min display counts down to zero for the last step in the program. (Press [**STOP**] to terminate a run at any time; the run will stop at the current step.) The green light above the [**STOP**] key will flash while the rotor decelerates. A tone will sound when the rotor has come to a complete stop.

NOTE

If you pressed [**ENTER/DISPLAY**] and [**START**] and then decide that you want to open the chamber door, you must press [**STOP**] before pressing [**DOOR**], even if the rotor is at rest.

<i>Action</i>	<i>Result</i>
5. After the rotor has stopped, press [DOOR].	The door is unlocked and the chamber vented.
6. Remove the rotor. Keep the chamber door closed between runs.	

RECALLING, CHANGING, OR DELETING A PROGRAM

Recalling a Program

A program that has been saved in memory can be recalled at any time.

<i>Action</i>	<i>Result</i>
1. Press [PROG] and the appropriate keypad number.	The first step in the program is displayed.
2. Press [STEP] repeatedly until the number of the selected step is displayed.	Run parameters for the designated step are displayed for 5 seconds.
3. To begin the run, press [ENTER/DISPLAY] and [START].	The run starts with step 1 and continues through all saved steps.

Changing a Program

<i>Action</i>	<i>Result</i>
1. Press [PROG] and the appropriate keypad number.	The first step in the program is displayed.

Action

2. Press [**STEP**] repeatedly until the number of the selected step is displayed.
3. Press the run parameter key to be changed.
4. Use the keypad to enter the new value.
5. Repeat steps 2 through 4 to change other run parameters. When all changes have been entered, press [**SAVE PROG**].

Result

Run parameters for the designated step are displayed for 5 seconds.

The **PROGRAM** display and the associated parameter display flash.

The revised program will remain in memory until further changes are made. Remember to record the changes on your Program Library sheet.

 **NOTE**

If a program is changed the program number blinks until [**SAVE PROG**] is pressed.

6. Press [**ENTER/DISPLAY**] and [**START**] to begin the programmed run (or press [**PROG**] to exit program mode and return to manual operation).

The run starts with step 1 and continues through all saved steps.

Deleting a Program

Action

1. Press [**PROG**] and the appropriate keypad number.
2. Using two fingers, press the [**DEL**] [**DEL**] keys simultaneously to activate the program-delete switch.

Result

The first step in the program is displayed.

All steps of the program will be deleted and the program will revert to default values.



Troubleshooting

This section lists possible malfunctions, together with probable causes and corrective actions. Maintenance procedures are given in Section 5. For any problems not covered here, contact Beckman Coulter Field Service (1-800-742-2345 in the United States; world-wide offices are listed on the back cover of this manual) for assistance.

NOTE

It is your responsibility to decontaminate the instrument, as well as any rotors and/or accessories, before requesting service by Beckman Coulter Field Service.

USER MESSAGES

User messages appear on the control panel (see Figure 4-1) to communicate information about the instrument or to alert you to abnormal conditions that need attention.

- In the case of informational messages, the message shines continuously until the condition changes. For example, when the instrument is turned on, **VAC** appears on the panel to indicate that the chamber pressure is above 500 microns. Once the pressure is below 500 microns, the message goes out.
- Other messages indicate “shutdown” conditions, which cause the rotor to decelerate to a stop. The appropriate message(s) will flash until the condition is corrected and the message is cleared. (Press **[ce]** to clear the message.) An intermittent tone will sound for 10 seconds to alert you that a shutdown has occurred. Refer to Table 4-1 to determine the nature of the condition and any recommended actions. If the problem persists, contact Beckman Coulter Field Service for assistance.

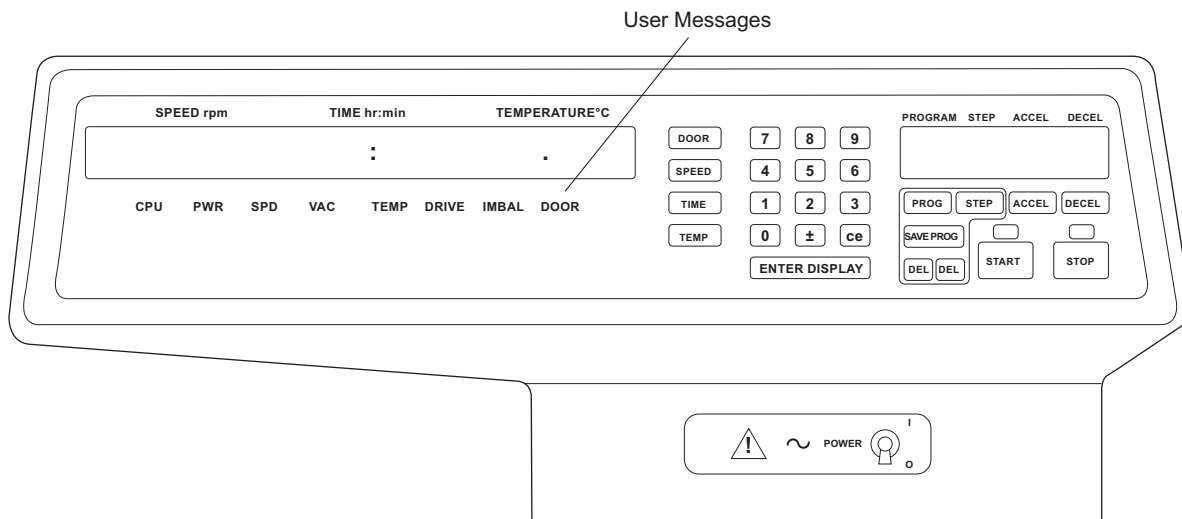

Figure 4-1. Location of User Messages on the Control Panel

Table 4-1. User Message Chart

Message	Definition/Result	Possible Cause and Recommended Action
CPU	Microprocessor malfunction or loss of program memory/ Deceleration without brake	If microprocessor malfunction was caused by power failure, the error can be cleared by turning instrument power off and back on; otherwise no operator solution. (In case of program memory loss, the instrument is still functional for manual operation.) Call Beckman Coulter Field Service.
PWR	Loss of power during centrifugation/Deceleration without brake	A power outage has occurred during the run. If power is restored while the rotor is still spinning, the run will resume and the rotor will return to set speed. If the rotor came to a stop, however, the operator will have to restart the run. In either case, PWR will continue flashing to indicate the outage. Press [ce] to clear the message.
SPD	Speed-related malfunction/Deceleration without brake	This message can indicate several speed-related conditions, including: <ul style="list-style-type: none"> run started without a rotor in the chamber; rotor imbalance at high speed; rotor overspeeding; unreliable speed signal. In all cases, shutdown of the instrument will result.

Table 4-1. User Message Chart (continued)

Message	Definition/Result	Possible Cause and Recommended Action
SPD (cont)		<p>NOTE</p> <p>Certain conditions may result in a 20-minute delay before the message can be cleared and the door opened. The delay is to ensure that the rotor has stopped spinning. The power MUST be left on so the instrument can calculate when the delay period is completed. If power to the instrument is lost or turned off, the remaining delay period is preserved, and the door will remain locked when power is restored until the delay period is completed.</p> <p>If SPD flashes on the panel, check the following:</p> <ul style="list-style-type: none"> • rotor has been properly installed; • instrument is resting on a level surface (a high-speed imbalance can result if the instrument is not level or if it has been moved during operation); • set speed is correct for rotor in use; • rotor load is within limits; • magnets on the rotor bottom are undamaged. <p>Press [ce] to clear the message. If message persists, call Beckman Coulter Field Service.</p>
VAC	Loss of chamber vacuum/Deceleration to 5000 rpm	<p>This message appears any time the door is open or the chamber pressure is above 500 microns. The message goes off as soon as the pressure is below 500 microns. If a pressure of 10 microns or less cannot be achieved in 45 minutes, the message reappears.</p> <p>If the pressure goes above 500 microns for more than 20 minutes during centrifugation, the message will begin to flash and the rotor decelerates to a stop. Press [ce] to clear the message. Verify that the chamber O-ring is undamaged and properly lubricated. Check for sample leakage, and clean the rotor chamber if necessary (see MAINTENANCE, Section 5).</p> <p>The vacuum pump may have moisture contamination. Leave the instrument on, with the door closed, for about 3 hours (or overnight) to allow the pump to purge itself of moisture. If the VAC message continues to flash when you attempt to restart the run, call Beckman Coulter Field Service.</p>
TEMP	Excessive or uncontrolled rotor temperature/Deceleration with brake	<p>Press [ce] to clear the message. If the message reappears, call Beckman Coulter Field Service.</p>
DRIVE	Drive has overheated/Deceleration with brake	<p>Check the air-intake louvers for blockage; clean them if necessary (see MAINTENANCE, Section 5). Press [ce] to clear the message. If the message reappears when you restart the run, call Beckman Coulter Field Service.</p>
IMBAL	Rotor imbalance at low speeds/Deceleration with brake	<p>Press [ce] to clear the message. Press [DOOR] to vent the chamber and open the door. Verify that the rotor is locked in place on the drive hub. Check for proper balance and placement of tubes and/or buckets.</p>
DOOR	Door open or unlocked/Deceleration with brake	<p>This message appears any time the chamber door is unlocked or open. Close the door properly before beginning the run. If DOOR flashes during centrifugation, there has been a door lock malfunction. <i>Do not attempt to open the door until the rotor stops.</i> When the rotor has stopped, check the door and the chamber O-ring. If there is no obvious cause for the message, call Beckman Coulter Field Service.</p>

RETRIEVING YOUR SAMPLE IN CASE OF POWER FAILURE

If facility power fails only momentarily, the instrument will resume operation when power is restored and the rotor will return to set speed. However, if the rotor came to a complete stop, you will have to restart the run when the power is restored. In either case, the **PWR** message will flash on the control panel to indicate that a power outage has occurred.



WARNING

Any maintenance procedure requiring removal of a panel exposes the operator to the possibility of electrical shock and/or mechanical injury. Therefore, turn the power OFF and disconnect the instrument from the main power source, and refer such maintenance to service personnel.

In the event of an extended power failure, it may be necessary to trip the door-locking mechanism manually to remove the rotor and retrieve your sample.



WARNING

The following procedure should be implemented only when absolutely necessary and only by qualified service personnel.

Action

1. Turn the power off and disconnect the power cord from the main power source.
2. Unscrew two screws to remove the door handle (see Figure 4-2).

Result

No lights on the control panel are lit.

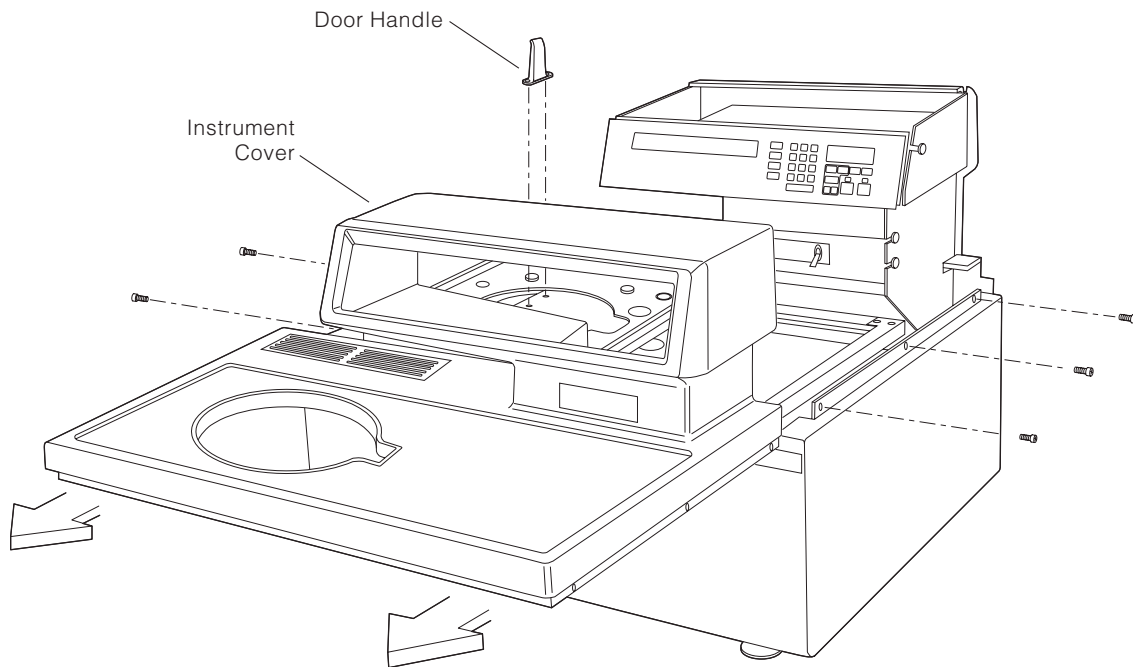

Figure 4-2. Removing the Top Cover of the Instrument

Action

Result

3. Remove three screws on each side of the top instrument cover and slide the panel housing toward you to remove it.
4. Turn the screw clockwise on the vacuum solenoid valve (Figure 4-3) until you hear air rushing into the chamber.
5. Turn the screw counterclockwise to its closed position.



CAUTION

LISTEN CAREFULLY. Do not proceed if any sound or vibration is coming from the drive.

Chamber vacuum is released. (If you hear a whining noise, the rotor is still spinning—close the valve and wait until the noise stops.) When the sound of rushing air stops, the vacuum is vented.

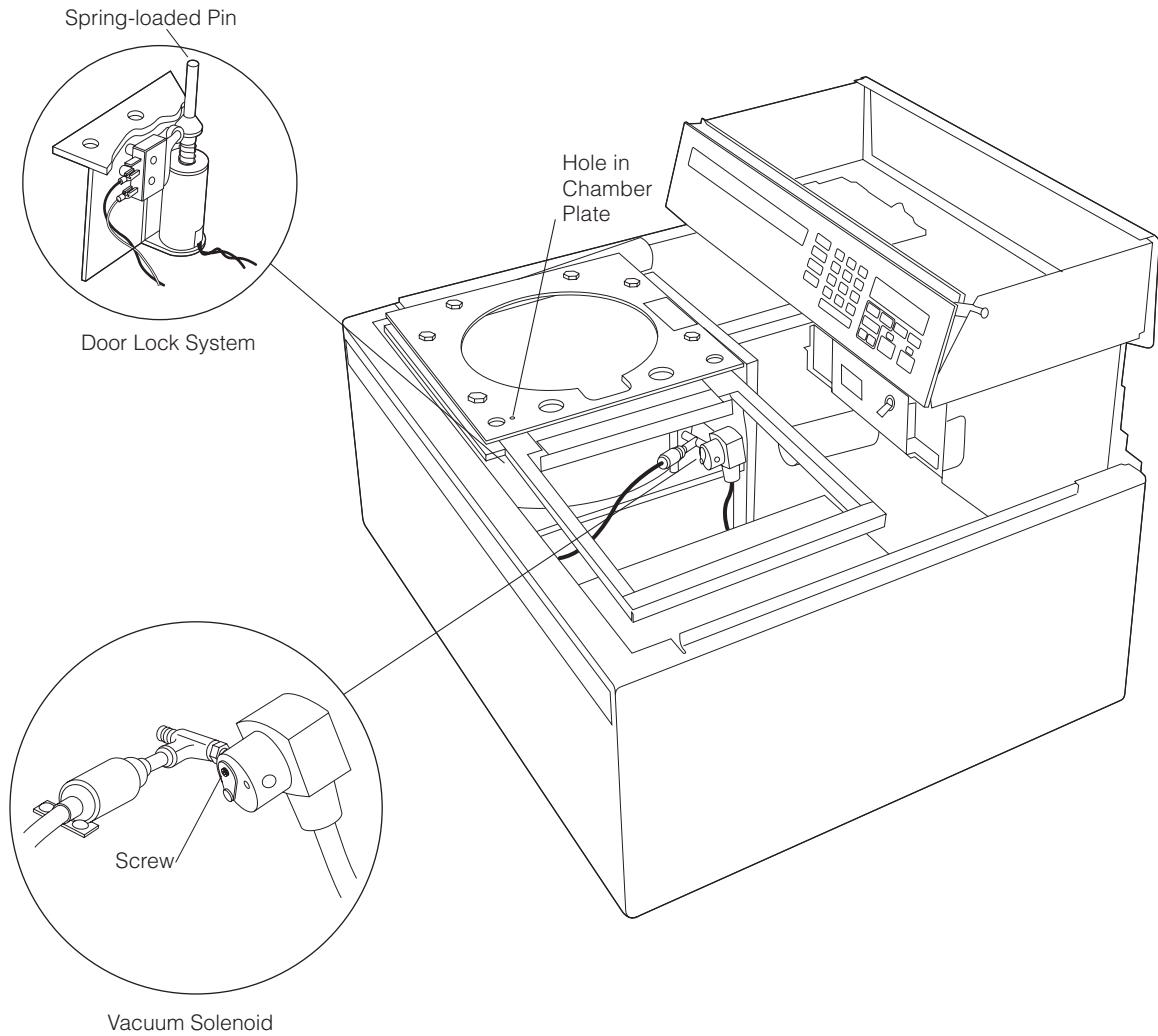

Figure 4-3. Door Lock System

Action

6. Insert a screwdriver or similar tool into the small hole in the chamber plate and depress the spring-loaded pin. With your other hand, pull back on the door to slide it open.

Result

If the rotor is still spinning, close the door and wait. The drive is very quiet and may emit no audible sounds below 10 000 rpm.



WARNING

NEVER try to slow or stop the rotor by hand.

Action

Result

7. After removing the rotor, replace the top panel and door handle by following the instructions above in reverse order.

CIRCUIT BREAKER

If the circuit breaker on the instrument trips repeatedly, call Beckman Coulter Field Service for assistance.

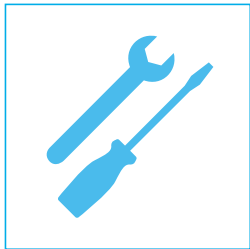

This section contains care and maintenance procedures that should be performed regularly. For maintenance not covered in this manual, contact Beckman Coulter Field Service (1-800-742-2345 in the United States; worldwide offices are listed on the back of this manual) for assistance. User messages and recommended actions are discussed in Section 4, TROUBLESHOOTING. Refer to the applicable rotor manual and Rotors and Tubes for instructions on the care of rotors and their accessories.

INSTRUMENT CARE

NOTE

It is your responsibility to decontaminate the instrument, as well as any rotors and/or accessories, before requesting service by Beckman Coulter Field Service.



WARNING

Any maintenance procedure requiring removal of a panel exposes the operator to the possibility of electrical shock and/or mechanical injury. Therefore, turn the power OFF and disconnect the instrument from the main power source, and refer such maintenance to service personnel.

VACUUM SYSTEM

For optimum performance of the vacuum system, keep the chamber O-ring (889164) and area around the O-ring clean. (Instrument O-rings have not been designed as bioseals for aerosol containment.) Wipe the area with a cloth dampened with a mild detergent such as Beckman Solution 555™ (339555), diluted 10 to 1 with water.

Chamber O-ring

Clean the O-ring every 3 or 4 months with alcohol and a lint-free cloth or tissue and coat it lightly, but evenly, with silicone vacuum grease (335148). If the O-ring becomes damaged, replace it as follows.

1. Remove the old O-ring with a blunt tool, being careful not to scratch the instrument.
2. Clean the groove and surrounding surface area with a cloth dampened with a mild detergent such as Beckman Solution 555 (339555).
3. Apply a light, even coat of silicone vacuum grease to the new O-ring and place it into the groove near the door.
4. With one thumb, hold the O-ring down (where it meets the door) while using your other hand to stretch it across the chamber. The stretching action will force the O-ring into place under the door.
5. Insert the rest of the O-ring into the groove.

Purging Moisture from the Vacuum Pump Oil

If a chamber pressure of 500 microns cannot be reached in about 3 minutes, there may be moisture in the vacuum pump oil. To purge this moisture:

1. Leave the instrument turned on with the door closed for about 3 hours or, if convenient, overnight.
2. Call your Beckman Coulter Field Service representative to change the vacuum oil if it remains contaminated. (The instrument will continue to display a **VAC** message after following the instruction in Step 1.)

DRIVE HUB

Check the drive hub and regularly wipe it clean as needed.

AIR-INTAKE AND EXHAUST LOUVERS

Regularly check that the air-intake and exhaust louvers are clean and unblocked. Use a vacuum cleaner or damp cloth to keep them clean. An optional air-intake filter (346436) is available.

CLEANING

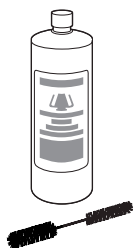

Keep instrument surfaces clean by wiping them with a cloth dampened with a mild detergent such as Beckman Solution 555 (diluted 10 to 1 with water). If salts or other corrosive materials are used, however, or if spillage occurs, wash all affected areas immediately. Do not allow corrosive materials to dry on the instrument. (Be careful not to spill liquid on the instrument where electrical or mechanical components could get damaged.)

NOTE

Before using any cleaning or decontamination methods except those recommended by the manufacturer, users should check with the manufacturer that the proposed method will not damage the equipment.

DECONTAMINATION



If the instrument and/or accessories are contaminated with radioactive or pathogenic solutions, follow appropriate decontamination procedures as determined by your laboratory safety officer. Refer to the chemical resistances list in Appendix A of *Rotors and Tubes*, or contact Beckman Coulter Field Service to ensure that the decontamination method does not damage any part of the instrument (or accessories).

STERILIZATION AND DISINFECTION

The top working surface is finished with urethane paint; the sides are finished with general purpose paint. Ethanol (70%)* may be used on both these surfaces. See Appendix A of *Rotors and Tubes* for more information regarding chemical resistance of instrument and accessory materials.

While Beckman Coulter has tested these methods and found that they do not damage the instrument, no guarantee of sterility or disinfection is expressed or implied. When sterilization or disinfection is a concern, consult your laboratory safety officer regarding proper methods to use.

STORAGE AND TRANSPORTATION

To ensure that the instrument does not get damaged, contact Beckman Coulter Field Service for specific instructions and/or assistance in preparing the equipment for transport or long-term storage. Temperature and humidity requirements for storage should meet the environmental requirements described under SPECIFICATIONS in Section 1 of this manual.

* Flammability hazard. Do not use in or near operating ultracentrifuges.

SUPPLY LIST

Contact Beckman Coulter Sales (1-800-742-2345 in the United States; worldwide offices are listed on the back of this manual) for information about ordering parts and supplies. A partial list of supplies is given below for your convenience. See the *Ultracentrifuge Rotors, Tubes & Accessories* catalog (BR-8101, available at www.beckmancoulter.com) for detailed information on ordering rotors, tubes, and accessories.

REPLACEMENT PARTS

Chamber O-ring	889164
Air-intake filter	346436

SUPPLIES

Spinkote lubricant (1 oz)	306812
Silicone vacuum grease (2 oz)	335148
Beckman Solution 555 (1 qt)	339555
Centrifuge logbook	330049
Master rotor logbook	339587

WARRANTY FOR THE OPTIMA™ TLX ULTRACENTRIFUGE

Subject to the exceptions and upon the conditions specified below, Beckman Coulter agrees to correct, either by repair, or at its election by replacement, any defects of material or workmanship which develop within one (1) year after delivery of the Optima TLX Ultracentrifuge (the product), to the original Buyer by Beckman Coulter or by an authorized representative provided that investigation and factory inspection by Beckman Coulter discloses that such defect developed under normal and proper use.

Some components and accessories by their nature are not intended to and will not function for as long as one (1) year. A complete list of such components or accessories is maintained at the factory and at each Beckman Coulter District Sales Office. The lists applicable to the products sold hereunder shall be deemed to be part of this warranty. If any such component or accessory fails to give reasonable service for a reasonable period of time, Beckman Coulter will repair or, at its election, replace such component or accessory. What constitutes either reasonable service and a reasonable period of time shall be determined solely by Beckman Coulter.

REPLACEMENT

Any product claimed to be defective must, if requested by Beckman Coulter, be returned to the factory, transportation charges prepaid, and will be returned to Buyer with the transportation charges collect unless the product is found to be defective, in which case Beckman Coulter will pay all transportation charges.

CONDITIONS

Beckman Coulter makes no warranty concerning products or accessories not manufactured by it. In the event of failure of any such product or accessory, Beckman Coulter will give reasonable assistance to the Buyer in obtaining from the respective manufacturer whatever adjustment is reasonable in light of the manufacturer's own warranty.

See the warranty that accompanies each rotor for ultracentrifuge rotor warranty information.

Beckman Coulter shall be released from all obligations under all warranties, either expressed or implied, if the product(s) covered hereby are repaired or modified by persons other than its own authorized service personnel, unless such repair by others is made with the written consent of Beckman Coulter, or unless such repair in the sole opinion of Beckman Coulter is minor, or unless such modification is merely the installation of a new Beckman Coulter plug-in component for such product(s).

DISCLAIMER

IT IS EXPRESSLY AGREED THAT THE ABOVE WARRANTY SHALL BE IN LIEU OF ALL WARRANTIES OF FITNESS AND OF THE WARRANTY OF MERCHANTABILITY AND THAT BECKMAN COULTER, INC. SHALL HAVE NO LIABILITY FOR SPECIAL OR CONSEQUENTIAL DAMAGES OF ANY KIND WHATSOEVER ARISING OUT OF THE MANUFACTURE, USE, SALE, HANDLING, REPAIR, MAINTENANCE, OR REPLACEMENT OF THE PRODUCT.

Beckman Coulter Worldwide Biomedical Research Division Offices

AUSTRALIA

Beckman Coulter Australia Pty Ltd
Unit D, 24 College St.
Gladesville, NSW 2111
Australia
Telephone: (61) 2 9844-6000
or toll free: 1 800 060 880
Fax: (61) 2 9844-6096
email: lifescienceaustralia@beckman.com

CANADA

Beckman Coulter (Canada) Inc.
6755 Mississauga Road, Suite 600
Mississauga, Ontario
Canada L5N 7Y2
Telephone: (905) 819-1234
Fax: (905) 819-1485

CHINA

Beckman Coulter Inc.
Beijing Representative Office
Unit 2005A, 2006-2009, East Ocean Center
Jian Guomenwai Avenue
Beijing 100004
China
Telephone: (86) 10 6515 6028
Fax: (86) 10 6515 6025, 6515 6026

EASTERN EUROPE/ MIDDLE EAST/NORTH AFRICA

Beckman Coulter International S.A.
22, Rue Juste-Olivier
Case Postale 301-303
CH-1260 Nyon, Switzerland
Telephone: (41) 22 994 07 07
Fax: (41) 22 994 07 00

FRANCE

Beckman Coulter France S.A.
Paris Nord II, 33/66 rue des Vanesses
B.P. 50359
Villepinte, France
95942 ROISSY CDG Cedex
Telephone: 01 49 90 90 00
Fax: 01 49 90 90 10
e-mail: bioresearch.france@beckman.com

GERMANY

Beckman Coulter GmbH
Europark Fichtenhain B-13
47807 Krefeld
Germany
Telephone: 49 21 513335
Fax: 49 21 51333633
e-mail: bioresearch.de@beckman.com

HONG KONG

Beckman Coulter Hong Kong Ltd.
12th Floor, Oxford House
979 King's Road
Taikoo Place, Hong Kong
Telephone: (852) 2814 7431, 2814 0481
Fax: (852) 2873 4511

ITALY

Beckman Coulter S.p.a.
Centro Direzionale Lombardo
Palazzo F/1, Via Roma 108
20060 Cassina de' Pecchi
Milano, Italy
Telephone: 02-953921
Fax: 02-95392264

JAPAN

Beckman Coulter K.K.
TOC Ariake West Tower
2-5-7, Ariake, Koto-ku
Tokyo 135-0063 Japan
Telephone: 03-5404-8359
Fax: 03-5404-8436

MEXICO

Beckman Coulter de Mexico S.A. DE C.V.
Avenida Popocatepetl #396
Colonia Gral. Pedro Maria Anaya
Codigo Postal 03340
Mexico, D.F. Mexico
Telephone: 52-55-9183-2800

NETHERLANDS

Beckman Coulter Nederland B.V.
Nijverheidsweg 21
3641 RP-Mijdrecht
Postbus 47
3640 AA Mijdrecht
The Netherlands
Telephone: 0297-230630
Fax: 0297-288082

SINGAPORE

Beckman Coulter Singapore Pte. Ltd.
116 Changi Road
Unit #03-01/02
Singapore 419718
Telephone: (65) 6339 3633
Fax: (65) 6336 6303

SOUTH AFRICA/SUB-SAHARAN AFRICA

Beckman Coulter
Stand 1A Primegro Park
Tonetti Street
1685 Halfway House
Johannesburg
Republic of South Africa
Telephone: (27) 11-805-2014/5
Fax: (27) 11-805-4120
e-mail: beckman@intekom.co.za

SPAIN

Beckman Coulter España S.A.
C/ Caleruega, 81
28033 Madrid, Spain
Telephone: 91 3836080
Fax: 91 3836096
email: bioresearch.espana@beckman.com

SWEDEN

Beckman Coulter AB
Archimedesvaegen 7
Box 111 56
SE-168 11 Bromma
Sweden
Telephone: (0)8 564 85 900
Telefax: (0)8 564 85 901

SWITZERLAND

Beckman Coulter International S.A.
22, Rue Juste-Olivier
Case Postale 301-303
CH-1260 Nyon
Switzerland
Telephone: 0800 850 810
Fax: 0848 850 810

TAIWAN

Beckman Coulter Taiwan Inc.
Taiwan Branch
8th Floor
216 Tun Hwa South Road, Section 2
Taipei 106, Taiwan
Republic of China
Telephone: (886) 2 2378 3456
Fax: (886) 2 2377 0408

TURKEY

Beckman Coulter Ltd.
E-5 Yanyol Faith Cad.
81410 Soganlik Kartal
Istanbul
Turkey
Telephone: 90 216 309 1900
Fax: 90 216 309 0090

UNITED KINGDOM

Beckman Coulter United Kingdom Ltd
Oakley Court
Kingsmead Business Park
London Road
High Wycombe
Buckinghamshire HP11 1JU
England, U.K.
Telephone: 01494 441181
Fax: 01494 447558
e-mail: beckman_uk@beckman.com

Authorized dealers in other countries.



Beckman Coulter, Inc. • 4300 N. Harbor Boulevard, Box 3100 • Fullerton, California 92834-3100
Sales and Service: 1-800-742-2345 • Internet: www.beckmancoulter.com • Telex: 678413 • Fax: 1-800-643-4366

