

SORVALL[®]

SORVALL[®]

RC-3B PLUS

**OPERATING
INSTRUCTIONS**

 **Kendro**
Laboratory Products



OPERATING INSTRUCTIONS

SORVALL[®] RC 3B PLUS *General Purpose Automatic Refrigerated Centrifuge*

Kendro Laboratory Products
Newtown, Connecticut
U.S.A.

SORVALL[®]

 **Kendro**
Laboratory Products

This manual is a guide to the use of the

SORVALL® RC 3B PLUS General Purpose Automatic Refrigerated Centrifuge

Data herein has been verified and is believed adequate for the intended use of the centrifuge. If the centrifuge or procedures are used for purposes over and above the capabilities specified herein, confirmation of their validity and suitability should be obtained, otherwise Kendro Laboratory Products does not guarantee results and assumes no obligation or liability. This publication is not a license to operate under, nor a recommendation to infringe upon, any process patents.

Publications prior to the Issue Date of this manual may contain data in apparent conflict with that provided herein. Please consider all data in this manual to be the most current.

WARNING, CAUTION and **NOTE** within the text of this manual are used to emphasize important and critical instructions.

WARNING informs the operator of a hazard or an unsafe practice that could result in personal injury, affect the operator's health, or contaminate the environment.

CAUTION informs the operator of an unsafe practice that could result in damage of equipment.

NOTE highlights essential information.

CAUTION and **WARNING** are accompanied by a hazard symbol  and appear in the left sidebar near the information they correspond to.

Important Safety Information

Certain potentially dangerous conditions are inherent to the use of all centrifuges. To ensure safe operation of this centrifuge, anyone using it should be aware of all safe practices and take all precautions described below and throughout this manual.



WARNING

When using radioactive, toxic, or pathogenic materials, be aware of all characteristics of the materials and hazards associated with them in the event leakage occurs during centrifugation. If leakage does occur, neither the centrifuge nor the rotor can protect you from particles dispersed in the air. To protect yourself, we recommend additional precautions be taken to prevent exposure to these materials, for example, use of controlled ventilation or isolation areas.

Always be aware of the possibility of contamination when using radioactive, toxic, or pathogenic materials. Take all necessary precautions and use appropriate decontamination procedures if exposure occurs.

Never use any material capable of producing flammable or explosive vapors or creating extreme exothermic reactions.

Never exceed the maximum rated speed of the installed rotor; to do so can cause rotor failure.

Always reduce (derate) rotor speed as instructed in this manual whenever:

- the rotor speed/temperature combination exceeds the solubility of the gradient material and causes it to precipitate.
- the compartment load exceeds the maximum allowable compartment load specified. See Chapter 3, Operation, page 3-8.

Failure to reduce rotor speed under these conditions can cause rotor failure.



CAUTION

Do not run or precool a rotor at the critical speed, as this will have a detrimental effect on centrifuge component life. See Chapter 3, Rotor Precool, page 3-3.

Do not operate the centrifuge with a rotor out of balance. To do so can cause damage to the centrifuge drive assembly.

Do not operate centrifuge without a rotor properly installed: rotor cover must be on and locked in place, and the rotor locked to the centrifuge drive. See rotor instruction manual.

The centrifuge must be leveled to avoid rotor imbalance during operation.

The centrifuge can be damaged if connected to the wrong voltage. Check the voltage before plugging the centrifuge into a power source. Kendro is not responsible for incorrect installation.

Always maintain the centrifuge in the recommended manner. See Chapter 4, Maintenance.

Table of Contents (continued)

APPENDIX

Warranty
 Index
 Blank Rotor Speed/Temperature Differential Graphs
 Decontamination Certificates

List of Illustrations

Figure	Page
1-1. RC-3B PLUS Centrifuge — Rear View	1-6
2-1. RC-3B PLUS Electrical Requirements	2-2
2-2. Dimensions of the RC-3B PLUS	2-3
2-3. Front Locking Stabilizer Adjustment	2-3
3-1. Location of Controls and Indicators	3-1
3-2. Brake Setting <i>vs</i> Deceleration Time	3-4
4-1. Air Filter Assembly Removal	4-5

List of Tables

Table	Page
3-1. Controls and Indicators	3-2
3-2. Maximum Compartment Mass	3-8

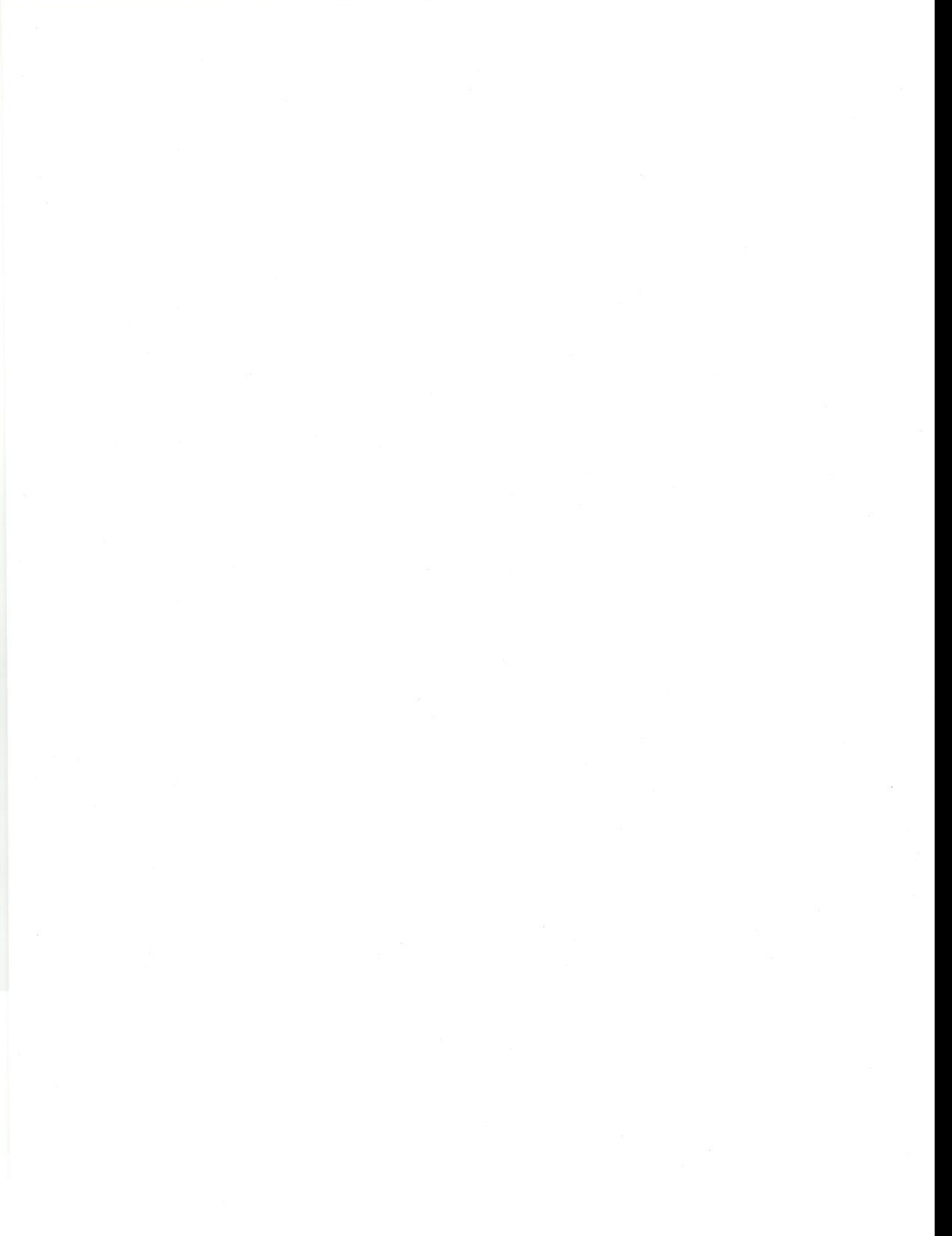

Chapter 1: DESCRIPTION

This manual provides you with the information you need to install, operate, and maintain your SORVALL® RC 3B PLUS General Purpose Automatic Refrigerated Centrifuge. If you encounter any problem concerning either operation or maintenance that is not covered in the manual, please contact our Marketing Technical Group for assistance. In the United States, telephone toll free – 800-522-7746. Outside the United States, contact your local distributor or agent for SORVALL® products.

General Description

The RC 3B PLUS is a large capacity, versatile, quiet and reliable centrifuge for low speed (to 6000 rpm) work designed to meet the needs of research and clinical laboratories, blood banks and plasmapheresis centers.

The centrifuge system has a fan-cooled brushless dc motor with automatic programmed acceleration and braking. The high-torque motor is balanced to ensure smooth, quiet operation over its full speed range and to promote long life for the bearings. A gyro-action drive with a square spindle drive shaft accepts a variety of SORVALL® rotors. A clear acrylic viewing port located in the center of the chamber door permits calibration of rotor speed with a stroboscope.

Temperature control is handled by a refrigeration system charged with environmentally-friendly CFC-free refrigerant. The refrigeration system consists of a low-temperature condensing unit with a twin cylinder, hermetically-sealed power assembly (motor and compressor), a finned condenser and two fans. The cooling system is designed to maintain chamber temperature to within 3°C of setpoint.

The centrifuge includes the following safety features: protective, armor plate steel guard within the cabinet; automatic shutoff of the drive motor for overspeed protection and of the refrigeration motor to prevent damage from overheating; electrical circuit breakers on the main power and the control panel circuits; operating controls which may be changed during operation without damage to the centrifuge; and a door interlock which prevents opening the chamber door while the rotor is in motion and/or starting of the rotor drive while the door is open.

Centrifuge Specifications

Operating Temperature Range	-20°C to +40°C (depending on the type and speed of the rotor in use)
Maximum Operating Speed*	6000 rpm**
Shortest Braking Time at Maximum BRAKE setting	approximately two times the acceleration time of the rotor
Average Heat Output During Operation	3.2 kW (11 000 BTU/h)
Electrical Requirements:	
Can be supplied for use on the following single phase power sources	200 V, 50/60 Hz, single phase
.....	208 V, 50/60 Hz, single phase***
.....	220 V, 50/60 Hz, single phase
.....	230 V, 50/60 Hz, single phase***
.....	240 V, 50/60 Hz, single phase
Circuit Breakers	30A (Main POWER Switch)
Current	24A
Dimensions:	
Width	76.2 cm (30 inches)
Depth	101.6 cm (40 inches)
Height	94.0 cm (37 inches) to top of deck
.....	120.6 cm (47.5 inches) to top of control panel
Rotor Chamber Diameter	58.4 cm (23 inches)
Mass (weight)	303.5 kg (669 lbs)

*Maximum speed is dependent on line voltage and rotor used.

**Speed in revolutions per minute (rpm) is related to angular velocity, ω , according to the following:

$$\omega = (\text{rpm}) \left(\frac{2\pi}{60} \right) = (\text{rpm}) (0.10472)$$

Where ω = rad/s. All further references in this manual to speed will be designated as rpm.

***CSA certification applied for.

Principles of Operation

The centrifuge is capable of two modes of operation STANDBY and RUN.

a. STANDBY Mode

The STANDBY mode exists whenever the following conditions exist:

- The POWER light is on.
- The RUN light is either off, indicating that the rotor is at zero speed, or it is blinking, indicating that the rotor is decelerating.
- The OPEN DOOR light is on, indicating the door gearmotor has retracted and the door can be opened.

Thirty seconds after power is turned on, the compressor will turn on until the selected chamber temperature is reached. The compressor will turn off for a minimum of 30 seconds, then turn on again, as necessary, to cool the chamber. The compressor will continue to cycle on and off as required to maintain chamber temperature.

b. RUN Mode

The RUN mode exists whenever the following conditions exist:

- The POWER light is on.
- The RUN light is on.
- The OPEN DOOR light is off, indicating that the door is closed and latched.

The conditions listed above will only exist when all steps necessary to enter the RUN mode from the STANDBY mode have been taken. Those steps are as follows:

1. Set the rev/min x 1000 dial at a speed other than 0.
2. Set the TIME dial for a specific amount of time or to HOLD.
3. Close the chamber door.
4. Press the START switch.
5. Eliminate an automatic shut-off condition (see page 1-4).

An automatic shut-off condition is one which will override the start command given when the START switch is pressed and either prevent the centrifuge from entering the RUN mode or cause it to transfer back to the STANDBY mode during a run. An automatic shut-off condition falls into two categories: an unprogrammed stop and a programmed stop.

Unprogrammed Stop

An unprogrammed stop occurs when an undesirable condition which affects centrifuge performance is detected. The following conditions would initiate an unprogrammed stop:

1. Chamber temperature exceeds the preset temperature by $7^{\circ}\text{C} \pm 3^{\circ}\text{C}$. This condition is indicated by illumination of the OVERTEMP light.
2. Excessive rotor imbalance. This condition is indicated by illumination of the IMBALANCE light.
3. Centrifuge overspeed (exceeding 6200 rpm ± 100).
4. Motor overtemperature.
5. Door open.

The condition that initiated an unprogrammed stop must be eliminated before the centrifuge can enter or reenter the RUN mode. If the condition persists, contact Kendro Service or your local representative for SORVALL® products.

NOTE When an **OVERTEMP** or **IMBALANCE** condition has been corrected, the light will remain lit until the **START** switch is pressed to reenter the **RUN** mode.

Programmed Stop

A programmed stop occurs as a result of an operation which has been deliberately induced by the operator to end the run. The following conditions would initiate a programmed stop.

1. Preset time period elapses.
2. TIME dial is manually reset to 0.
3. The STOP switch is pressed.

When an automatic shut-off condition occurs during the RUN mode, the centrifuge will immediately transfer to the STANDBY mode. As a result, braking (if selected) will begin, the RUN light will start to blink, and the OPEN DOOR light will come on when the rotor has come to a complete stop.

Door Operation



WARNING

The door gas springs must be checked periodically for proper functioning (see Chapter 4). If gas pressure is not sufficient the door will not stay open and possible injury could result.



CAUTION

To avoid damaging the door latching mechanism, never force the door open and always close it gently.



WARNING

The mechanical door release lever is provided for emergency sample recovery only and should never be used to operate the centrifuge with the door open or to open the door when the rotor is spinning.

In the event of a power failure, the brake will not operate. Wait until the rotor stops spinning before using the mechanical door release lever. Reaching into the rotor chamber before the rotor has stopped spinning could cause personal injury.

a. Normal Door Operation

The door interlock prevents the chamber door from being opened while the rotor is in motion and prevents the centrifuge from entering the RUN mode if the door is not properly closed and latched.

The door is hinged on the left side and has a latch on the right side. To open the door, lift the latch and pull up on the door. Two gas springs counterbalance the weight of the door and hold it in the open position. To close the door, push down on it gently but firmly.

b. Mechanical Door Interlock Override

The door interlock prevents the chamber door from being opened while a rotor is spinning. However, if the main power is shut off, either manually or as the result of a power failure or system malfunction, the RC 3B PLUS chamber door will not open. A mechanical override is provided to allow sample recovery in the case of an emergency.

The mechanical door release lever is recessed in the back cabinet panel (see figure 1-1). To open the chamber door, push the door release lever with a pencil or similar object, then carefully lift the door latch and pull the door open.

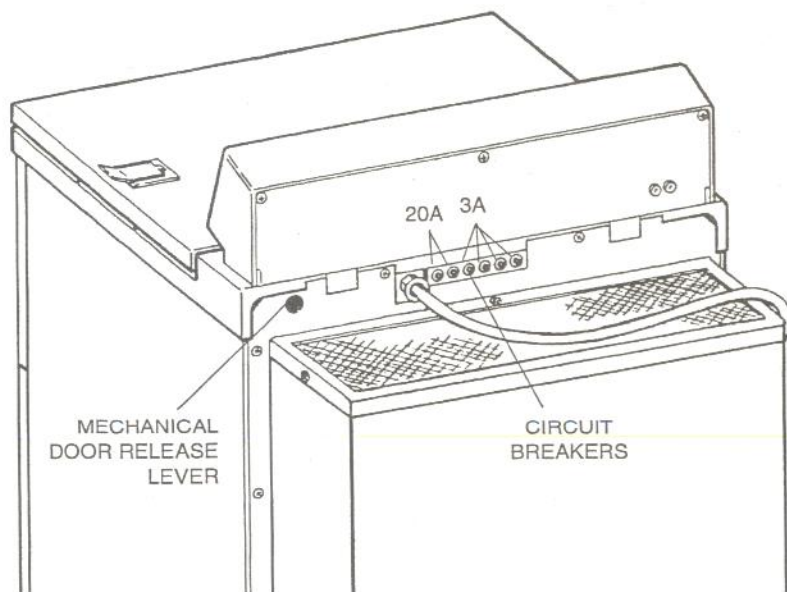
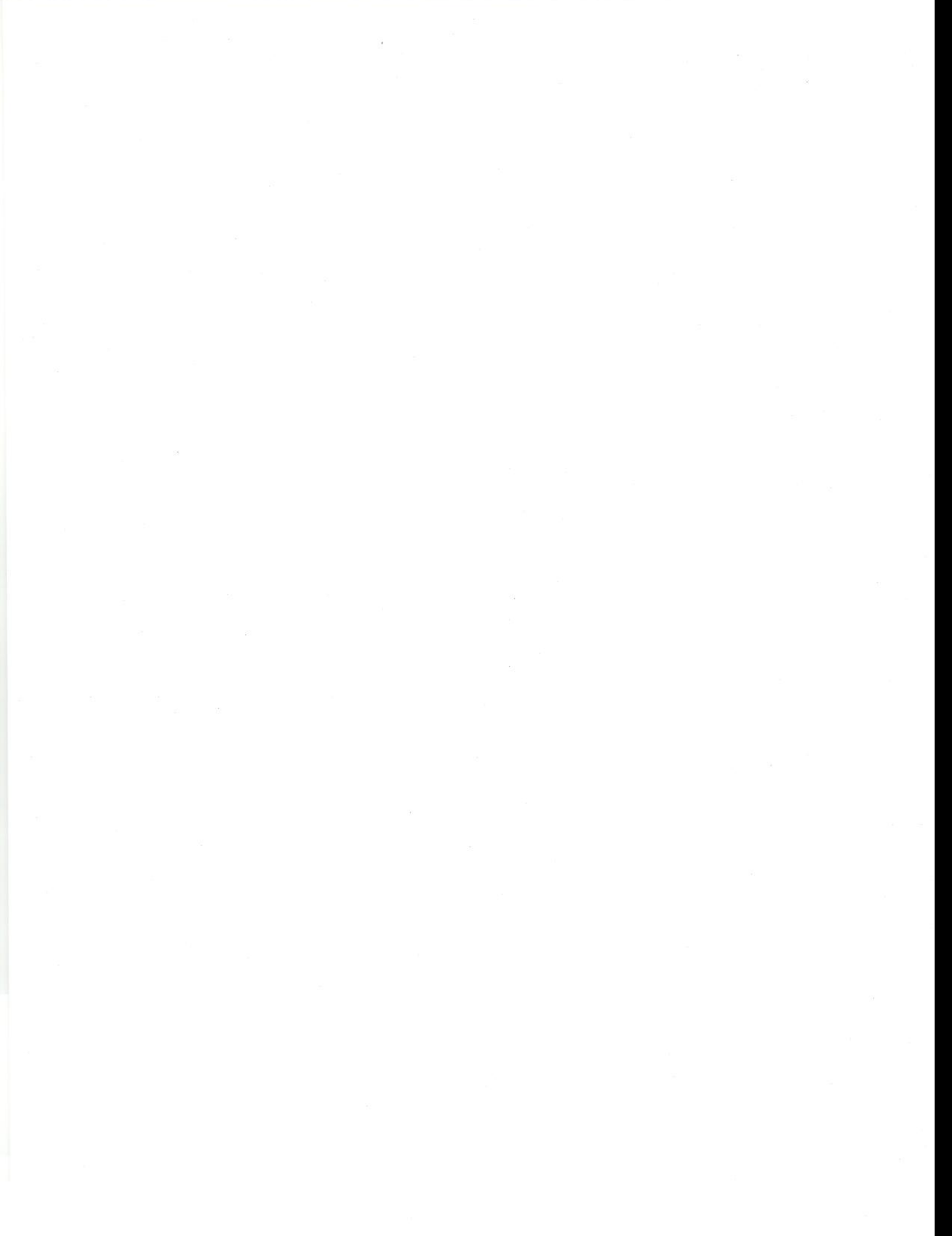

Figure 1-1. RC 3B PLUS Centrifuge — Rear View



Chapter 2: INSTALLATION

This chapter contains instructions to prepare your SORVALL® RC 3B PLUS for operation.

Inspection

When you receive your centrifuge, carefully inspect it for any signs of shipping damage. If you find damage, report it immediately to the transportation company and file a damage claim, then notify Kendro.

Check the parts received with the centrifuge against the shipping list; if any parts are missing, contact Kendro (see back cover).

Electrical Requirements

The RC 3B PLUS has specific power requirements and must be connected to the correct supply for proper performance. The nameplate on the back panel of the cabinet specifies one of the following:

- 200 V, 50/60 Hz, single phase, 30 A
- 208 V, 50/60 Hz, single phase, 30 A*
- 220 V, 50/60 Hz, single phase, 30 A
- 230 V, 50/60 Hz, single phase, 30 A*
- 240 V, 50/60 Hz, single phase, 30 A



CAUTION

If the power cord is connected to the wrong voltage, it can cause damage to the centrifuge. Check the voltage listed on the nameplate before plugging the power cord into the power source. Kendro is not responsible for incorrect installation.

The line voltage should be checked with a voltmeter, then you should verify that the voltage indicated on the nameplate on the back panel is in agreement with the measured line voltage.

If the line voltage is within $\pm 10\%$ of the nominal voltage specified above, you may notice variations in the performance of the centrifuge. If the line voltage exceeds this tolerance, it may damage the centrifuge.

The single phase system includes a ground wire and two power leads with 30 A circuit protectors as shown in figure 2-1.

The RC 3B PLUS is equipped with a three-wire cord with three-prong cap including connection to fit Hubbell Receptacle No. 9330 or equivalent. This cord may be changed to meet local electrical code requirements; the green and yellow wire is the ground and must be connected to the centrifuge frame.

*CSA certification applied for.

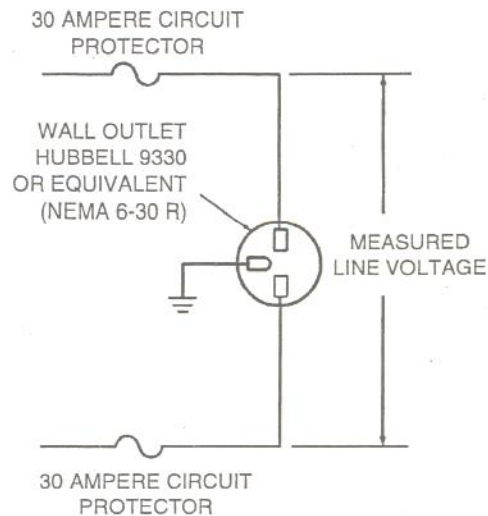

Figure 2-1. RC-3B PLUS Electrical Requirements

Location

Locate the centrifuge on a level floor. Free air circulation is very important for the centrifuge to function properly, as is ambient temperature. During centrifuge operation, surrounding temperatures exceeding 35°C (95°F) will cause components to fail prematurely. Therefore, avoid areas near heat sources (for example, heating pipes and radiators). Also, avoid close grouping of centrifuges or other heat-producing laboratory equipment. The cooler the location, the better the operating conditions will be for the RC 3B PLUS. Figure 2-2 gives the dimensions of the RC 3B PLUS.

Installation

To install the RC 3B PLUS:

1. Roll the centrifuge to the selected location.
2. Remove the 9/16 inch wrench from inside the rotor chamber. Open the chamber door using the mechanical door release lever which is recessed in the back cabinet panel of the centrifuge (Chapter 1, figure 1-1).
3. Using the 9/16 inch wrench to lower the two locking stabilizers in the front of the centrifuge until they lightly contact the floor. Rotate each stabilizer an additional four turns. This will raise the center caster about 6 mm (1/4 inch) off the floor. Check that the centrifuge does not rock on its four support points, the two front stabilizers and the two rear casters (see figure 2-3). **Read the CAUTION.**



CAUTION

Locate the centrifuge on a level floor to avoid imbalance during operation.

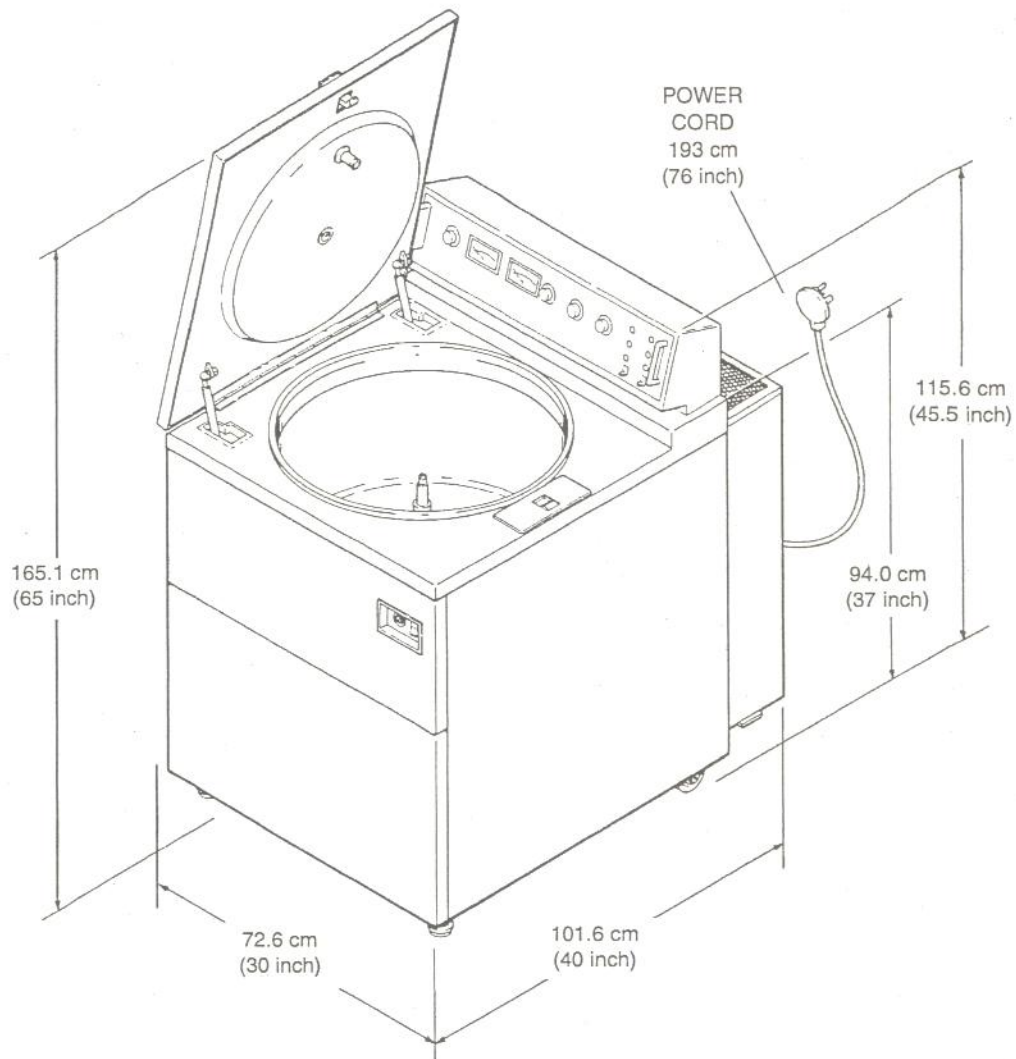

Figure 2-2. Dimensions of the RC-3B PLUS

4. Be sure the POWER switch is set to "0", then plug in the centrifuge power cord. The RC 3B PLUS is now ready for use.

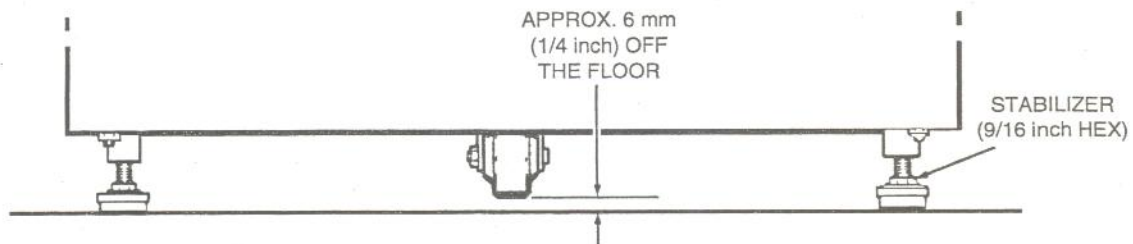
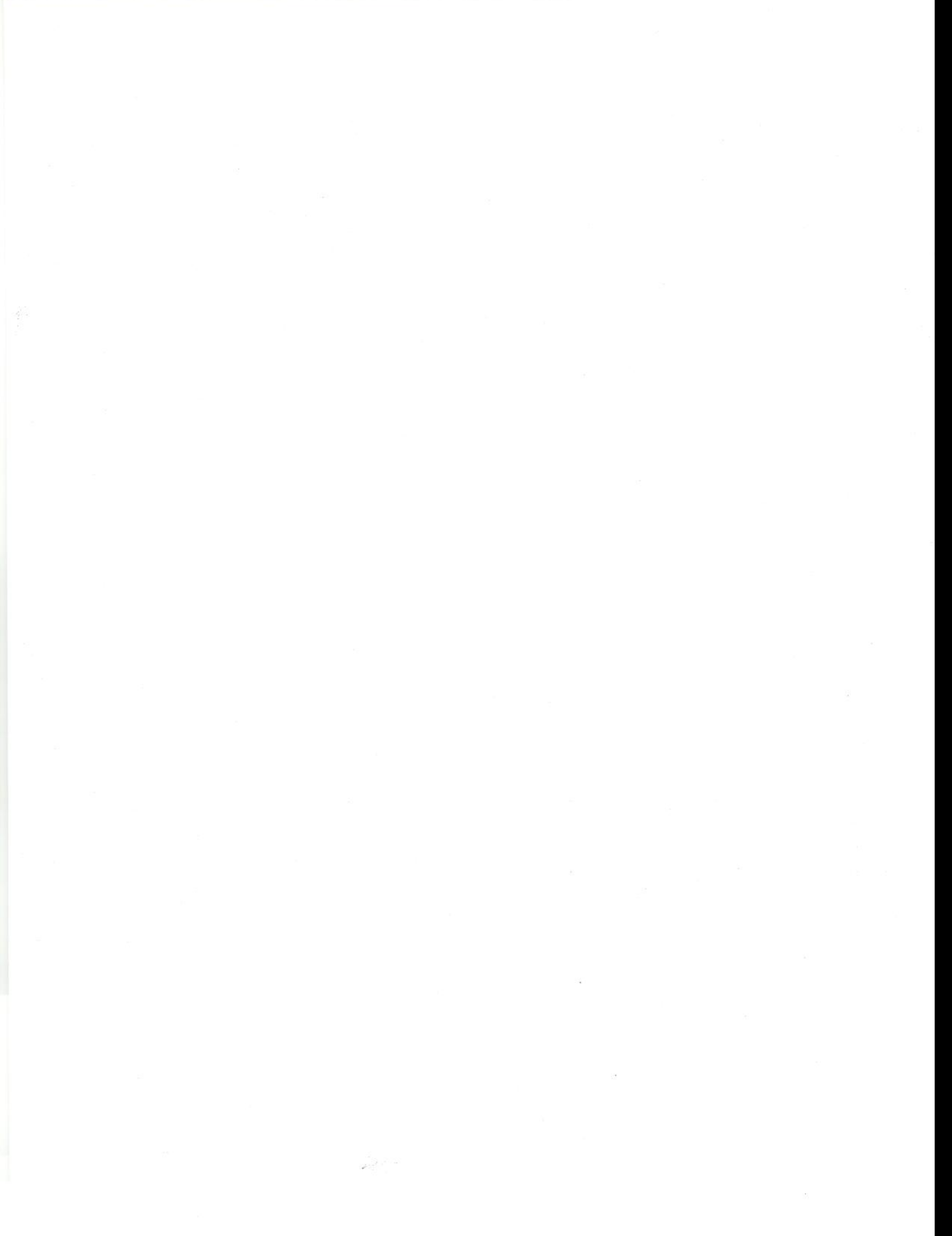

Figure 2-3. Front Locking Stabilizer Adjustment



Chapter 3: OPERATION

This chapter describes the function of each operating control and indicator and provides the information necessary to operate your SORVALL® RC 3B PLUS Centrifuge.

Controls and Indicators

Figure 3-1 shows the location of operating controls and indicators. Table 3-1 lists them by item number and describes their function.

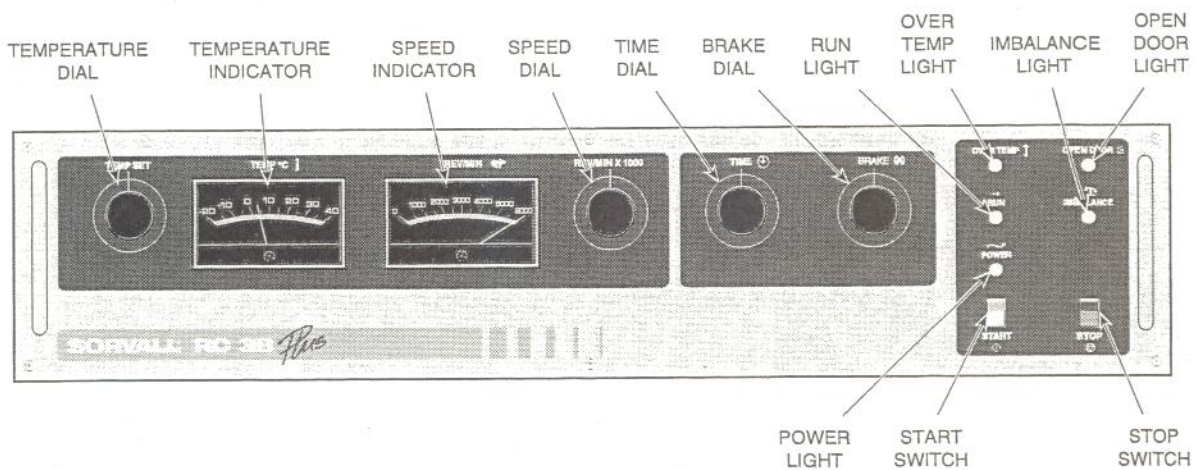
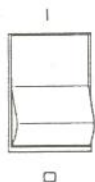

Figure 3-1. Location of Controls and Indicators

**Table 3-1. Controls and Indicators
(keyed to figure 3-1)**

Name	Function
Temperature (TEMP SET) Dial	Sets desired chamber temperature.
Temperature (TEMP °C) Indicator	Indicates actual chamber temperature, $\pm 3^{\circ}\text{C}$.
Speed (REV/MIN) Indicator	Indicates actual rotor speed in rpm, ± 20 rpm or 1%, whichever is greater.
Speed (REV/MIN x 1000) Dial	Sets desired run speed in thousands of rpm.
TIME Dial	Sets duration of centrifuge run from 0 to 30 minutes (60 Hz) or from 0 to 35 minutes (50 Hz); the HOLD setting allows a run without a time limit.
BRAKE Dial	Sets desired amount of braking for end of run, which will vary depending on the rotor in use (figure 3-2 can be used as a guide).
RUN light	Comes on as soon as the centrifuge enters the RUN mode and stays on until a stop is initiated. Starts to blink when the rotor begins to decelerate; when the rotor comes to a full stop, the light will go off.
OVER TEMP light	When lit, warns of an overtemperature condition and initiates a stop if the centrifuge is in operation.
IMBALANCE light	When lit, warns of an imbalance condition and initiates a stop if the centrifuge is running.
OPEN DOOR light	When lit, indicates either that the chamber door is not shut and latched properly (prevents the start of a run) or that a run has ended and the chamber door can be opened.
POWER light	When lit, indicates that the main power is on.
START Switch	When pressed, switches the centrifuge from the STANDBY mode to the RUN mode.
STOP Switch	When pressed, switches centrifuge from RUN mode to STANDBY mode and initiates preset braking.

POWER Switch



This switch is located in the upper right corner of the front cabinet panel. The power switch (a 30 A circuit breaker) is an on/off toggle switch that, when set to "I", applies power to the centrifuge.

Rotor Precool

NOTE Before operating a new centrifuge for the first time, be sure that it has been properly installed as explained in Chapter 2.

The rotor should be precooled before operation, either in the centrifuge chamber or in a refrigerator or cold room. To precool the rotor in the centrifuge chamber:

1. Carefully install the empty rotor on the centrifuge drive spindle (see paragraph below for additional rotor information).
2. Close the chamber door.
3. Turn the POWER switch to "I".
4. Set the rev/min x 1000 dial for 1000 rpm.
5. Set the TIME dial for 20 minutes.
6. Set the BRAKE dial for 10.
7. Set the TEMP SET dial to the desired temperature.
8. When the reading on the TEMP°C indicator is the same as the setting on the TEMP SET dial, press the START switch.

NOTE The **OVERTEMP** light will come on if the difference between the indicated temperature and set temperature is greater than $7^{\circ}\text{C} \pm 3^{\circ}\text{C}$, and the centrifuge will not start. To override this condition, wait until the indicated temperature is the same as the set temperature, then press the **START** switch.



WARNING

When loading the rotor, be sure not to exceed the maximum compartment mass of the rotor (see rotor instruction manual). If maximum compartment mass is exceeded, the maximum speed must be lowered (see Reducing Speed for Rotor Compartment Loads in Excess of Design Mass, page 3-8). Failure to do so can cause rotor failure which could result in personal injury and/or centrifuge damage.

Rotor Installation, Loading and Balancing

Install, load, and balance the rotor according to the instructions given in the rotor instruction manual.

**CAUTION**

Carefully, place the rotor on the centrifuge drive spindle. The drive can be damaged if rotors are dropped onto it.

Do not operate the centrifuge in the **RUN** mode without a rotor in place on the drive spindle; to do so can damage the centrifuge drive.

**CAUTION**

When running blood bags, we recommend setting the **BRAKE** dial between 4 and 6; a higher braking rate could cause sample stirring and resuspension of blood cells.

A brake setting of 5 or less should be used when a superspeed rotor is used with the drive adapter. This will allow the rotor to come to a slow stop and prevent the rotor locking screw from jarring loose, which could result in damage to the rotor and/or centrifuge.

Operation

To keep your centrifuge in good working condition and ensure accurate test results, we recommend that you check the speed control, timer, and temperature control twice a year following the procedures given in Chapter 4, Customer Control Inspection, page 4-2.

To perform the run:

1. Set the TEMP SET dial to the desired run temperature. Calculation of temperature offset is discussed on page 3-6.
2. Set the rev/min x 1000 dial to the desired run speed.

NOTE If either a SORVALL® superspeed rotor or the LA/S-400 Rotor is used, accelerate the rotor to 5000 rpm first, then gradually increase the speed to 6000 rpm. Direct acceleration to top speed may cause an overspeed condition and consequent automatic shut-down.

3. Set the TIME dial for the desired run time, up to 30 minutes for 60 Hz units or 35 minutes for 50 Hz units, or turn it to the HOLD position.
4. Set the BRAKE dial to the desired braking rate. Figure 3-2 shows a typical braking curve when a fully-loaded H-6000A Rotor decelerates from 3800 rpm. Since many variables can affect braking rate (for example, type of rotor in use and load size) you should experiment with braking rates and collect data for future use.

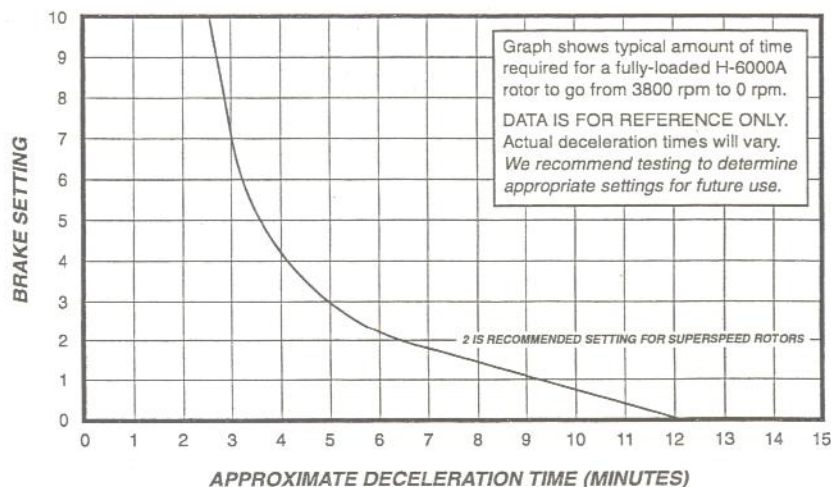

Figure 3-2. Brake Setting vs. Deceleration Time

**CAUTION**

If the centrifuge run ends early due to an unprogrammed stop, locate and correct the problem that caused the stop before attempting to reenter the **RUN** mode.

5. Close the chamber door.
6. Push the **START** switch. The rotor will accelerate to the preset speed and the centrifuge will continue to operate until a programmed stop is initiated.

NOTE Any of the RC 3B PLUS controls may be reset during operation without damaging the centrifuge.

To end the run:

1. Allow one of the following programmed stops to occur:
 - let the timer complete the preset interval;
 - turn the **TIME** dial to 0;
 - press the **STOP** switch.

NOTE When a stop is initiated, the **RUN** light will begin to blink indicating that the rotor is decelerating. The **OPEN DOOR** light will go on when the rotor reaches zero speed, signaling that the run is over.

2. Wait for the **OPEN DOOR** light to come on, then open the chamber door.
3. Remove the rotor (or just the specimen).
4. Close the chamber door.

NOTE To prevent condensation from turning into ice, keep the chamber door closed.

Rotor Speed/Temperature Differential Compensation

The temperature offset between indicated and sample temperature depends upon centrifuge efficiency and location, ambient temperature, type of rotor, and rotor speed. When sample temperature is critical, the required offset should be determined for each specific run.

For example, to derive a +4°C sample temperature with an H-4000 rotor at a speed of 4000 rpm in an ambient temperature of 25°C, it is necessary to set the **TEMP SET** dial at approximately +1°C, or 3 degrees cooler than the desired sample temperature.

**CAUTION**

The temperature offset technique should be used on all runs at either low or high speeds to prevent overtemperature or freezing of sample.

NOTE An ambient temperature of 30°C or less is required to obtain specified cooling efficiency. At higher ambient temperatures, it may be necessary to lower the operating speed to maintain sample temperature.

To plot a correction curve and create a graph for each rotor in each centrifuge, it is necessary to plot the **set** temperature versus the **actual** sample temperature for the rotor used at a specific operating speed and ambient temperature.

NOTE Blank rotor speed/temperature differential charts are provided in back of this manual.

More accurate temperature offset data can be obtained and plotted by doing a test run and dynamically calibrating a specific rotor/centrifuge/desired speed combination and ambient condition. Using an immersible centrigrade thermometer calibrated in 1.0°C increments, perform the procedure given below.

1. Select the desired sample temperature.
2. Prepare two centrifuge tubes or bottles with a test fluid and balance them according to instructions in rotor instruction manual.

NOTE The test fluid must be compatible with aluminum and have a freezing point below the desired sample temperature.

3. Precool the thermometer to 1.0°C below the desired sample temperature.
4. Set the TEMP SET dial to the desired sample temperature.
5. Install an empty rotor, and when the TEMP°C indicator reaches the selected temperature, precool the rotor (see page 3-3).
6. When the precool time has elapsed, load the prepared sample tubes or bottles into opposing rotor compartments and run the rotor at the desired speed for the anticipated length of the run with the BRAKE dial set to 5.
7. When the run time has elapsed and the rotor has stopped, open the door, then quickly open one rotor compartment and immerse the precooled thermometer into the test fluid. Agitate the thermometer in the liquid for approximately five to ten seconds. Record the indicated temperature.

8. If necessary, adjust the setting of TEMP SET dial as required by the recorded temperature. For example, if the recorded temperature is 2°C warmer than the desired temperature, reset the temperature setting downward 2°C.
9. Record all data for future use.

Running Hazardous Material



WARNING

If using pathogenic, toxic, or otherwise hazardous materials in the RC 3B PLUS, we recommend that the centrifuge be located in a biohazard safety enclosure and operated with all appropriate safety precautions to prevent exposure to these materials.

The RC 3B PLUS Centrifuge is designed with a refrigeration system that operates independently of the laboratory environment. Because the centrifuge chamber is not designed for biocontainment, some vapors or aerosols released from uncapped, leaking, or broken tubes may leak from the chamber during operation. Once a run is completed and the chamber door is opened, the vapors or aerosols which have concentrated in the chamber will be released into the laboratory area. For this reason, when materials which are pathogenic, toxic, or otherwise hazardous in nature are to be run, the centrifuge should be located in a biohazard safety enclosure and operated using all appropriate safety precautions. **Read the WARNING regarding hazardous materials found on the Safety Information Page in the front of this manual.**

Use appropriate decontamination procedures should exposure to any hazardous material occur. See Chapter 4 for procedure to follow if a centrifuge or rotor that has been used with a hazardous material must be returned to our service facilities for repair.

Reducing Speed for Rotor Compartment Loads in Excess of Design Mass

There is a maximum allowable compartment mass established for each centrifuge rotor (see Table 3-2). To prevent rotor failure, the total contents of any compartment, including specimen, tubes, cover, and adapters (if used), must not exceed the figure given in Table 3-2 unless rotor speed is reduced proportionately.

Strict adherence to the maximum allowable compartment mass or reduced speed (see page 3-7) is required to prevent rotor failure. **Read the WARNING on the Safety Information Page in front of this manual.**

The rotor speed is reduced in proportion to the square root of the ratio for the maximum allowable compartment mass to the actual compartment mass (including specimen, tubes, covers, and adapters). If the compartment mass is more than that specified for the rotor, the reduced speed can be determined by using the formula given below.

$$\text{Reduced Speed} = \text{Max Speed} \times \sqrt{\frac{\text{Maximum Compartment Mass}}{\text{Actual Compartment Mass}}}$$

Table 3-2. Maximum Compartment Mass

Rotor	Maximum Compartment Mass (grams)	Maximum Rotor Speed (rpm)
H-2000B	750**	2800
H-4000	2575	5250
H-6000A	2575	5000
HBB-6	2800	5000
HBB-12	3820	2900
HB-4*	250	6000
HS-4*	1035	6000
HL-2B	2000	3300
LA/S-400	90**	6000
SS-34*	115	6000
SA-600*	115	6000
SE-12*	30	6000
SM-24*	27	6000

*Requires use of adapter, Catalog Number 55222.

**Does not include bucket (contents only).

Chapter 4: MAINTENANCE

This chapter describes routine maintenance procedures that should be performed on a regular basis. As the user, it is your responsibility to make certain these procedures are performed when necessary. Also, to keep your centrifuge in good working condition and ensure accurate test results, we recommend that, in addition to these routine procedures, you have the speed control, timer, temperature control, and rotor imbalance detector checked periodically by a Kendro Service Representative or other qualified service personnel because occasionally, these controls may need to be recalibrated. If further service is needed, contact the nearest representative for SORVALL® products.



WARNING

Because of the high voltages in this centrifuge, personnel who are not trained in electronics must not test or repair the electrical circuits.

If hazardous materials have been processed in the centrifuge, take all necessary precautions when cleaning or servicing the centrifuge to avoid personal exposure to contamination.

Inspection and Cleaning

a. Inspection

Inspect the centrifuge each week for signs of wear, encrusted biological deposits, and general cleanliness.

b. Cleaning

Rotor Chamber

The rotor chamber should be kept clean and wiped dry routinely to maintain efficient cooling. Wash the chamber with a mild, nonalkaline dishwashing liquid, then rinse and dry with a soft absorbent cloth.

Use 70% ethanol to disinfect the rotor chamber or a 2% glutaraldehyde solution to sterilize it. For general radioactive decontamination, use a solution of equal parts of 70% ethanol, 10% SDS, and water. Follow this with ethanol rinses then deionized water rinses. Dry with a soft absorbent cloth. Dispose of all wash solutions in proper radioactive waste containers. **Read the CAUTION.**



CAUTION

Chlorides are extremely harmful to aluminum alloy rotors and can cause stress corrosion cracking. Therefore, if chlorides are used to disinfect the chamber, be sure to rinse the chamber thoroughly with water to remove all of the chloride cleanser.

Periodically defrost the rotor chamber to maintain efficient cooling; frost on the inner walls act as an insulation between the chamber and the refrigerant. To defrost the chamber, install a rotor and close the chamber door. Set the TEMP SET dial for 40°C and run the centrifuge until the frost melts (approximately 5 minutes). When the rotor comes to a complete stop, remove the rotor and wipe the chamber dry. The chamber can also be defrosted by leaving the chamber door open and the main power off until the frost melts; wipe chamber dry.

Drive Spindle

Wipe the spindle with a soft cloth before a rotor is installed to reduce the chance of the rotor sticking to the spindle. If necessary, to remove deposits, the spindle may be washed with warm water; make sure it is wiped dry before installing the rotor.

Cabinet

Clean the enameled cabinet panels with a household wax cleaner. Use a mild, nonalkaline detergent and water to clean the top deck.

Refrigeration System

To maintain the efficiency of the refrigeration system, the air filter should be cleaned every three to six months (see page 4-3 Cleaning the Air Filter).

Door Gas Springs

Periodically check that the door gas springs are functioning properly by opening the chamber door and making sure it remains open. The gas springs counterbalance the weight of the door and hold it in the open position. Also, check that the gas spring bracket is not cracked. If the chamber door will not stay open or if the gas spring bracket is cracked, contact your local Service Representative.



WARNING

The door gas springs must be checked periodically for proper functioning. If gas pressure is not sufficient the door will not stay open and possible injury could result.

Customer Control Inspection

To keep your centrifuge in good working condition and ensure accurate test results, we recommend that you check the speed control, timer and temperature at least twice a year following the procedures given on the next page.

If the biannual inspection reveals inaccurate results for any of these controls (that is, Speed Control, Timer, or Temperature), contact your local Kendro Service Representative for SORVALL® Products or qualified service technician because occasionally, these controls need to be recalibrated.

Speed Control

1. Precool rotor and chamber if desired.
2. Prepare a sample of test fluid. Load and balance the rotor according to the instructions given in the individual rotor instruction manual.
3. Open the chamber door and install the rotor. Close the chamber door.

NOTE The chamber door must be closed to do this procedure.

4. Set the POWER switch to "I".
5. Set the run parameters: TEMP SET dial, TIME dial, rev/min x 1000 dial, and BRAKE dial, to the desired settings for a normal run application.
6. Press the START switch. When the rotor has reached the preset rpm value, verify the rev/min reading using a strobe tachometer following the instructions supplied with the tachometer. Check the rotor through the viewing port located in the center of the chamber door. The reading given by the strobe tachometer should be in agreement with the rev/min indicator (located on the front panel of the centrifuge) to ± 20 rpm or 1%, whichever is greater.
7. Repeat this procedure at any other speed ranges that are commonly used in your laboratory protocols.

Timer

1. Precool rotor and chamber if desired.
2. Prepare a sample of test fluid. Load and balance the rotor according to the instructions given in the individual rotor instruction manual.
3. Open the chamber door and install the rotor. Close the chamber door.

4. Set the POWER switch to "I".
5. Set the run parameters: TEMP SET dial, rev/min x 1000 dial, BRAKE dial, and TIME dial to the desired settings for a normal run application.
6. Press the START switch. Using a stopwatch, verify that the centrifuge shuts off when the preset time on the TIME dial has elapsed ($\pm 10\%$).
7. Repeat this procedure at any other time ranges that are commonly used in your laboratory protocols.

Temperature

NOTE The TEMP°C indicator on the RC 3B PLUS measures actual rotor chamber temperature only.



CAUTION

The temperature offset technique should be used on all runs at either low or high speeds to prevent overtemperature or freezing of sample.

To check sample temperature is correct, prepare a sample load and run at temperature ranges commonly used in your laboratory protocols following the Rotor Speed/Temperature Differential Compensation procedure given on pages 3-6 and 3-7 of this manual.

Then, compare this data with Rotor Speed/Temperature Differential curves previously developed for your laboratory protocols.

Lubrication

All components are prelubricated and require no further lubrication. The refrigeration unit is hermetically sealed and the ball bearings in the gyro-action drive assembly and the centrifuge motor are permanently lubricated.



WARNING

When the main power shuts off, the brake will not operate. Wait until the rotor stops spinning before using the mechanical override. Reaching into the rotor chamber before the rotor has stopped spinning could cause personal injury.

Emergency Sample Recovery

If the main power shuts off because of a power failure or a system malfunction while the rotor is spinning, the RC 3B PLUS chamber door will not open. A mechanical override is provided to allow sample recovery in the case of an emergency. This procedure should never be used routinely and is intended for emergency sample recovery only.

The mechanical door release lever is recessed in the back cabinet panel (Chapter 1, figure 1-2). To open the chamber door, push the door release lever with a pencil or similar object, then carefully lift the door latch and pull the door open.

Cleaning the Air Filter

NOTE To maintain the efficiency of the refrigeration system, the air filter should be cleaned every three to six months.

1. Unplug the centrifuge power cord.
2. Using a 9/16 wrench, raise the two locking stabilizers (this will lower the center caster). Then, access the bottom of the backpack.
3. From the left side of the centrifuge, grasp the handle on the air filter assembly and pull downward (see figure 4-1). Remove the air filter assembly.

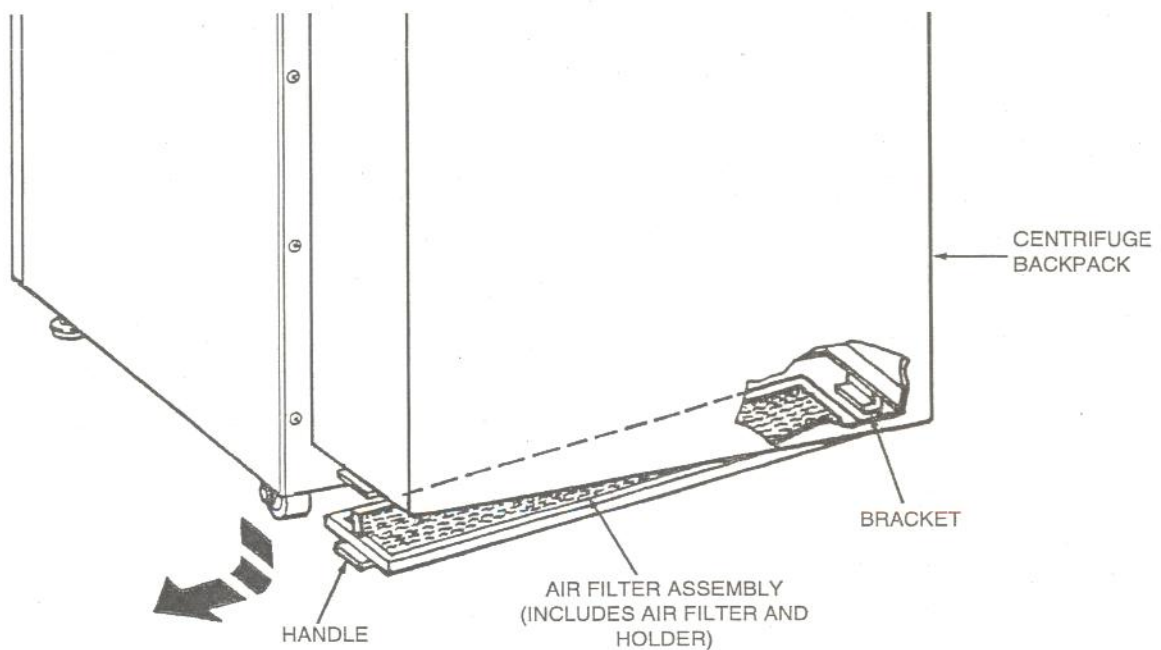

Figure 4-1. Air Filter Assembly Removal

4. Clean the air filter assembly by rinsing in warm water. If the air filter assembly is being reinstalled proceed to step 6. However, if the air filter can no longer be cleaned by rinsing in warm water or if it is damaged, replace the air filter as described in step 5. The catalog number to order a replacement air filter is 55466.
5. Replace the air filter as follows:
 - a. The air filter is slightly smaller than the air filter holder and is held in place by a small piece of foam at one end of the holder. Slide the air filter into the foam and the filter will "pop up" out of the holder. Discard the air filter.
 - b. While holding one end of the new air filter (Catalog No. 55466) against the foam, lower the other end into the holder. The spring action of the foam will retract against the air filter and hold it in place.
6. Reinstall the air filter assembly making sure the right side of the assembly engages the small bracket on the backpack. Once the assembly is engaged, gently push upward to secure in place.

Circuit Breakers

The RC 3B PLUS has seven circuit breakers. The primary power circuit breaker is located on the front cabinet panel (POWER switch). Six circuit breakers are located on the rear console panel (as shown in figure 1-2). One 20A breaker protects the drive circuitry, one 20A breaker protects the refrigeration circuitry, and the remaining four 3A breakers protect the power supply.

If a circuit breaker trips, it can be reset by pushing the reset button on the breaker. Repeated tripping indicates a fault in the system, in which case you should contact a Kendro Service Representative.

Parts Ordering Information

To order replacement parts, telephone toll free 800-522-7746 in the United States. Outside the United States, contact your local representative or agent for SORVALL® products. Be sure to provide a description of the part plus the centrifuge model and serial number.

Service Decontamination Policy



WARNING

Because of the characteristics of the samples likely to be processed in this centrifuge, biological or radioactive contamination may occur. Always be aware of this possibility and take normal precautions. Use appropriate decontamination procedures should exposure occur.

If a centrifuge or rotor that has been used with radioactive or pathogenic material requires servicing by Kendro personnel, either at the customer's laboratory or at a Kendro facility, comply with the following to ensure the safety of all personnel.

1. Clean the centrifuge or rotor to be serviced of all encrusted material and decontaminate it (see Maintenance Section of the centrifuge or rotor instruction manual) prior to servicing by the Kendro representative or returning to the Kendro facility. There must be no radioactivity detectable by survey equipment.

The SORVALL® Product Guide contains descriptions of commonly used decontamination methods and a chart showing method compatibility with various materials. The centrifuge or rotor instruction manual contains specific guidance about cleaning and decontamination methods appropriate for the product it describes.

Clean and decontaminate your centrifuge or rotor as follows:

- a. Remove rotor from the rotor chamber.
- b. Remove, wash, and decontaminate motor sealing gasket and pad.
- c. Drain line plugs and clean drain line.
- d. Decontaminate lid, rotor chamber, and drive using an appropriate method.
- e. Remove all encrusted material from around the motor and drive assemblies.

For rotors:

Remove tubes, bottles, and adapters from the rotor and decontaminate rotor using an appropriate method. If tubes or rotor caps are stuck in the rotor, or the rotor lid is stuck, notify Kendro representative; be prepared with the name and nature of the sample so the Kendro Chemical Hazards Officer can decide whether to authorize the rotor's return to a Kendro facility.

2. Complete and attach Decontamination Information Certificate (in the back of your rotor or instrument manual) to the centrifuge or rotor before servicing or return to Kendro facility. If Certificate is not available, attach a written statement verifying decontamination (what was contaminant and what decontamination method was used).

If the centrifuge or rotor must be returned to a Kendro facility:

1. Contact your Kendro representative to obtain a Return Service Order# (RSO#); be prepared with the name and serial number of the centrifuge or rotor and the repairs required.
2. Send item(s), with the RSO# clearly marked on the outside of packaging, to the address obtained from your Kendro representative.

NOTE United States federal regulations require that parts and instruments must be decontaminated before being transported. Outside of the United States refer to local regulations.

If a centrifuge or rotor to be serviced does not have a Decontamination Information Certificate attached, and in Kendro's opinion presents a potential radioactive or biological hazard, the Kendro representative will not service the equipment until proper decontamination and certification is complete. If Kendro receives a centrifuge or rotor at its Service facilities which, in its opinion, is a radioactive or biological hazard, the sender will be contacted for instructions as to the disposition of equipment. Disposition costs will be borne by the sender.

Decontamination Information Certificates are included with these instructions. Additional certificates are available from the local Account or Service Representative. In the event these certificates are not available, a written statement certifying that the unit has been properly decontaminated and outlining the procedure used will be acceptable.

NOTE The Service Representative will note on a Customer Service Repair Report if decontamination was required and, if so, what the contaminant was and what procedure was used. If no decontamination was required, it will be so stated.

APPENDIX

Warranty

Kendro Laboratory Products, L.P. makes no warranty of any kind, expressed or implied, except as stated in this warranty policy.

The SORVALL® RC 3B PLUS General Purpose Centrifuge is warranted to be free from defects in material and workmanship for a period of one year from the date of delivery. Kendro will repair or replace and return free of charge any part which is returned to its factory within said period, transportation prepaid by user, and which is found upon inspection to have been defective in materials or workmanship. This warranty does not apply to any damage to any instrument resulting from: normal wear and tear; misuse; abuse; use of electrical currents or circuits other than those specified on the plate affixed to the instrument; or use of any rotor other than those intended for use in this instrument.

Kendro reserves the right to change, alter, modify or improve any of its instruments without any obligation whatsoever to make corresponding changes to any instrument previously sold or shipped.

The forgoing obligations are in lieu of all other obligations and liabilities including negligence and all warranties, of merchantability or otherwise, expressed or implied in fact or by law, and sate our entire and exclusive liability and buyer's exclusive remedy for any claim or damages in connection with the sale or furnishing of goods or parts, their design, suitability for use, installation or operation. Kendro will in no event be liable for any special or consequential damages whatsoever, and our liability under no circumstances will exceed the contract price for the goods for which liability is claimed.

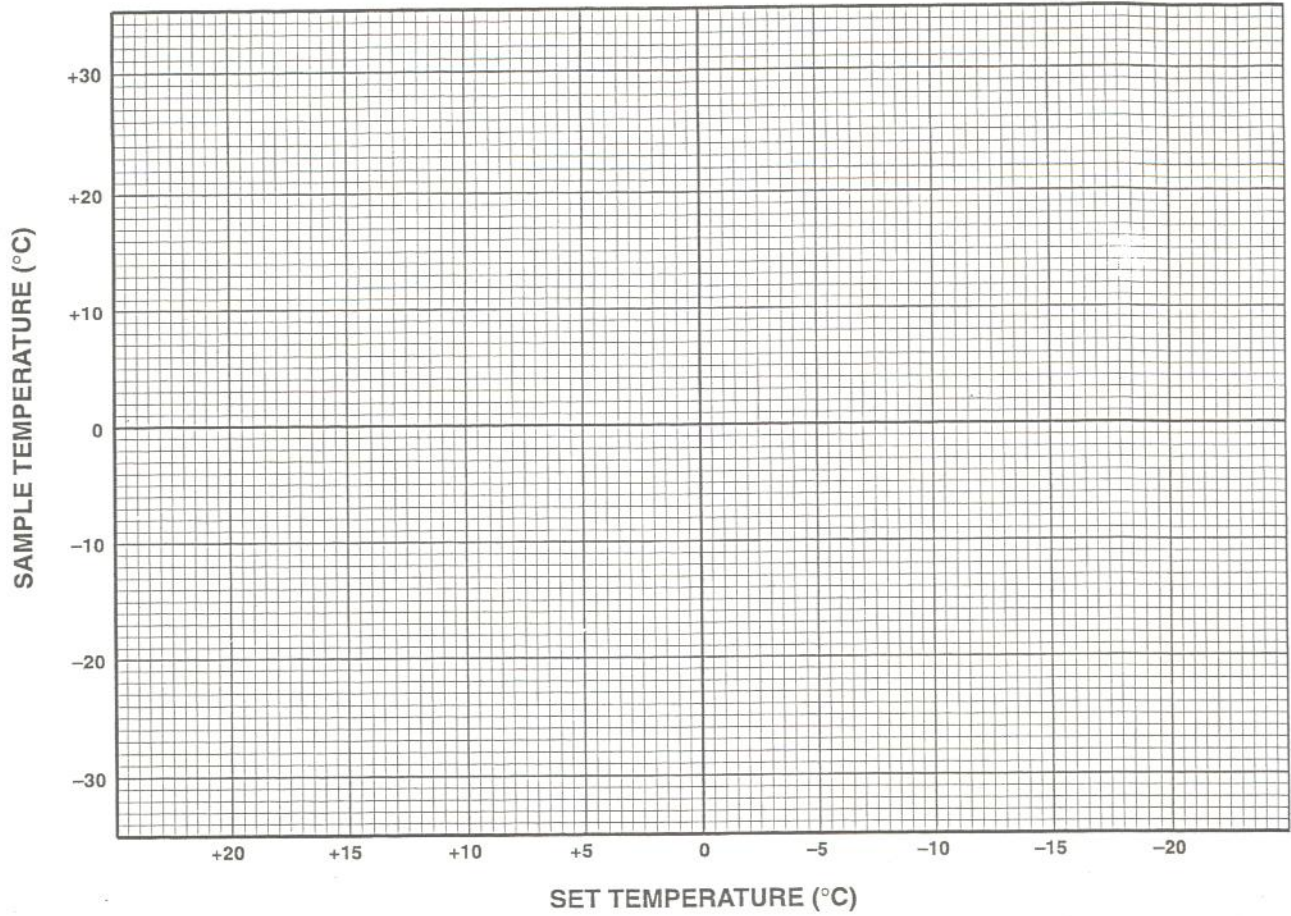

Rotor Speed/Temperature Differential Chart for

Rotor _____

Instrument _____

Ambient Temperature _____

Rotor Speed _____

Blank Rotor Speed / Temperature Differential Graph

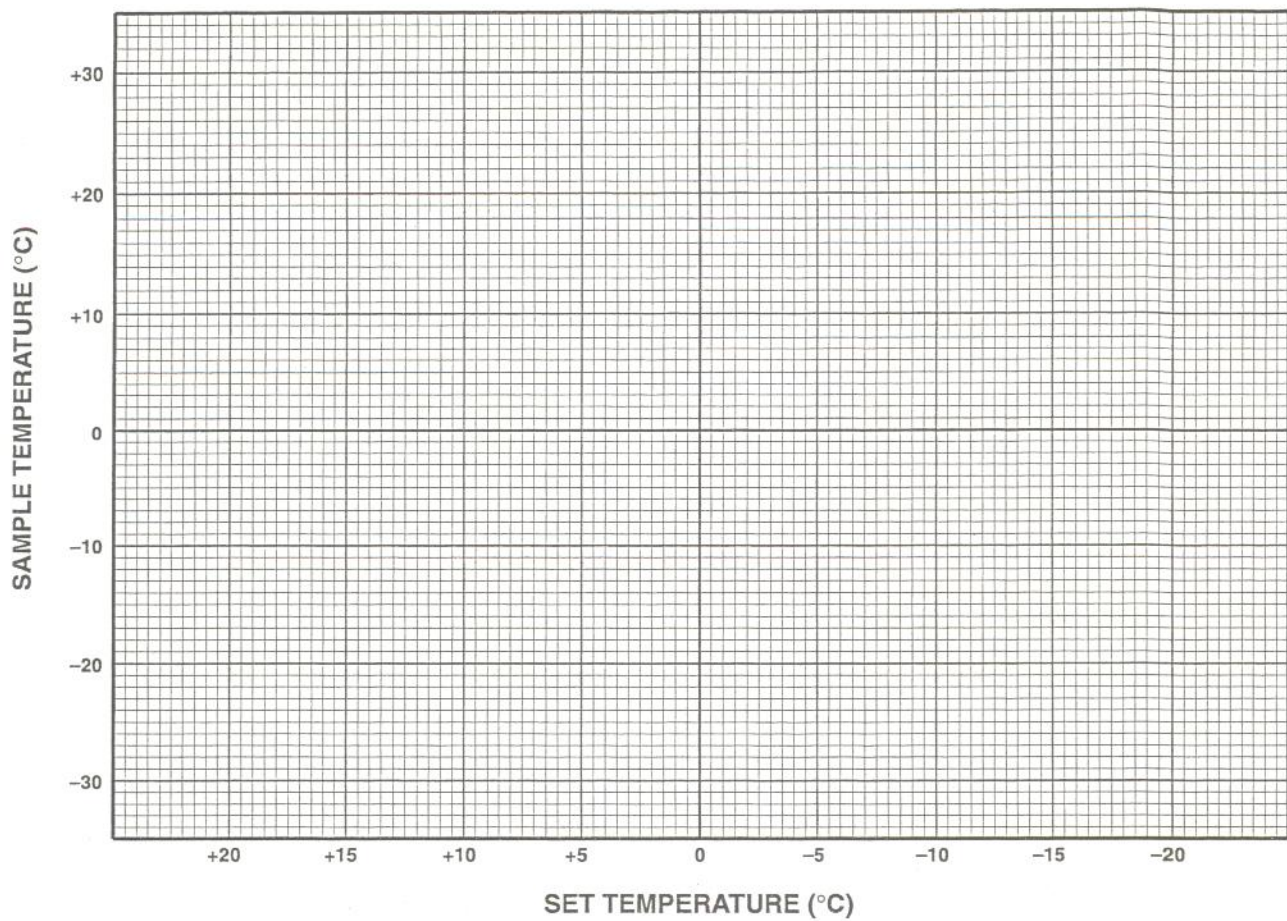

Rotor Speed/Temperature Differential Chart for

Rotor _____

Instrument _____

Ambient Temperature _____

Rotor Speed _____

Blank Rotor Speed / Temperature Differential Graph

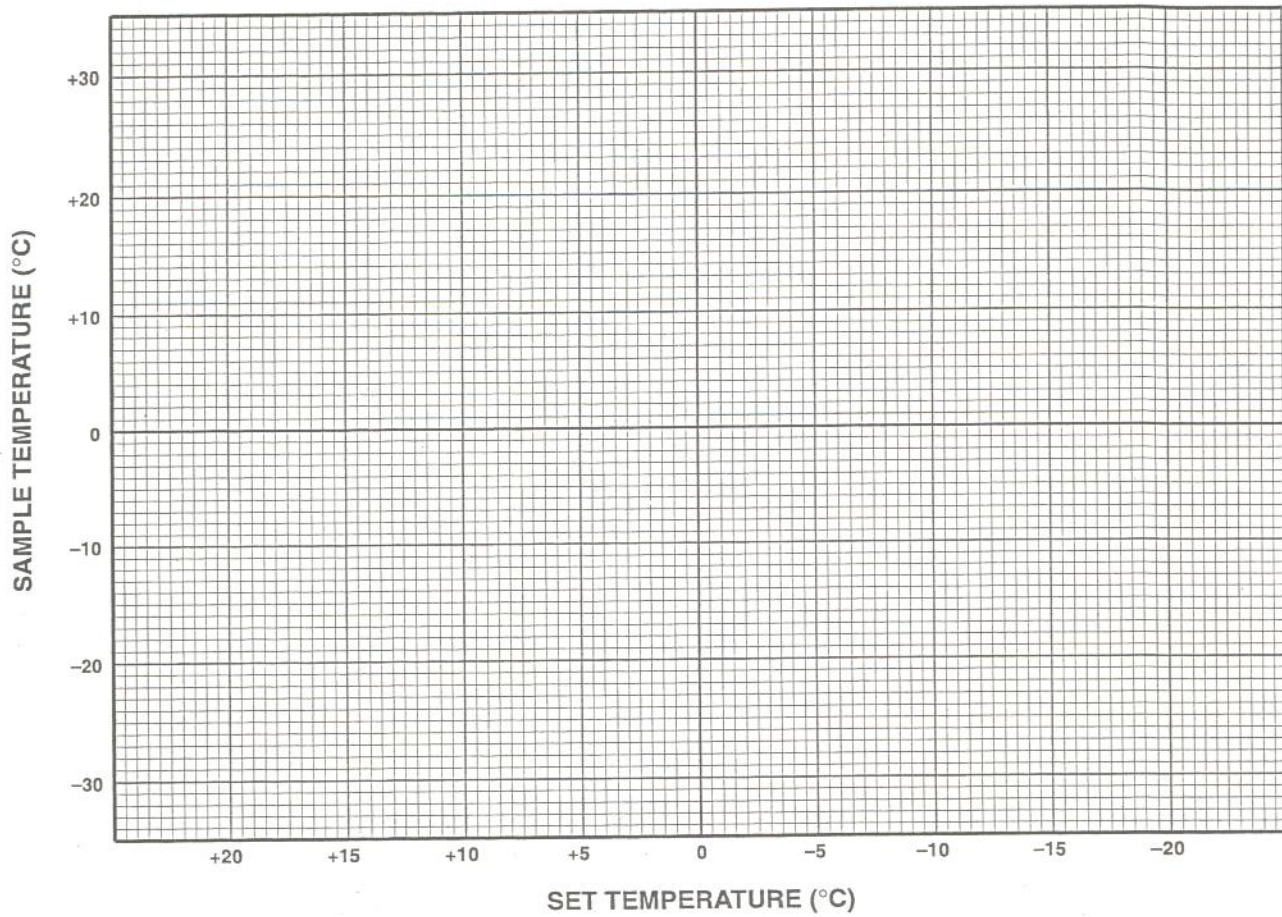

Rotor Speed/Temperature Differential Chart for

Rotor _____

Instrument _____

Ambient Temperature _____

Rotor Speed _____

Blank Rotor Speed / Temperature Differential Graph

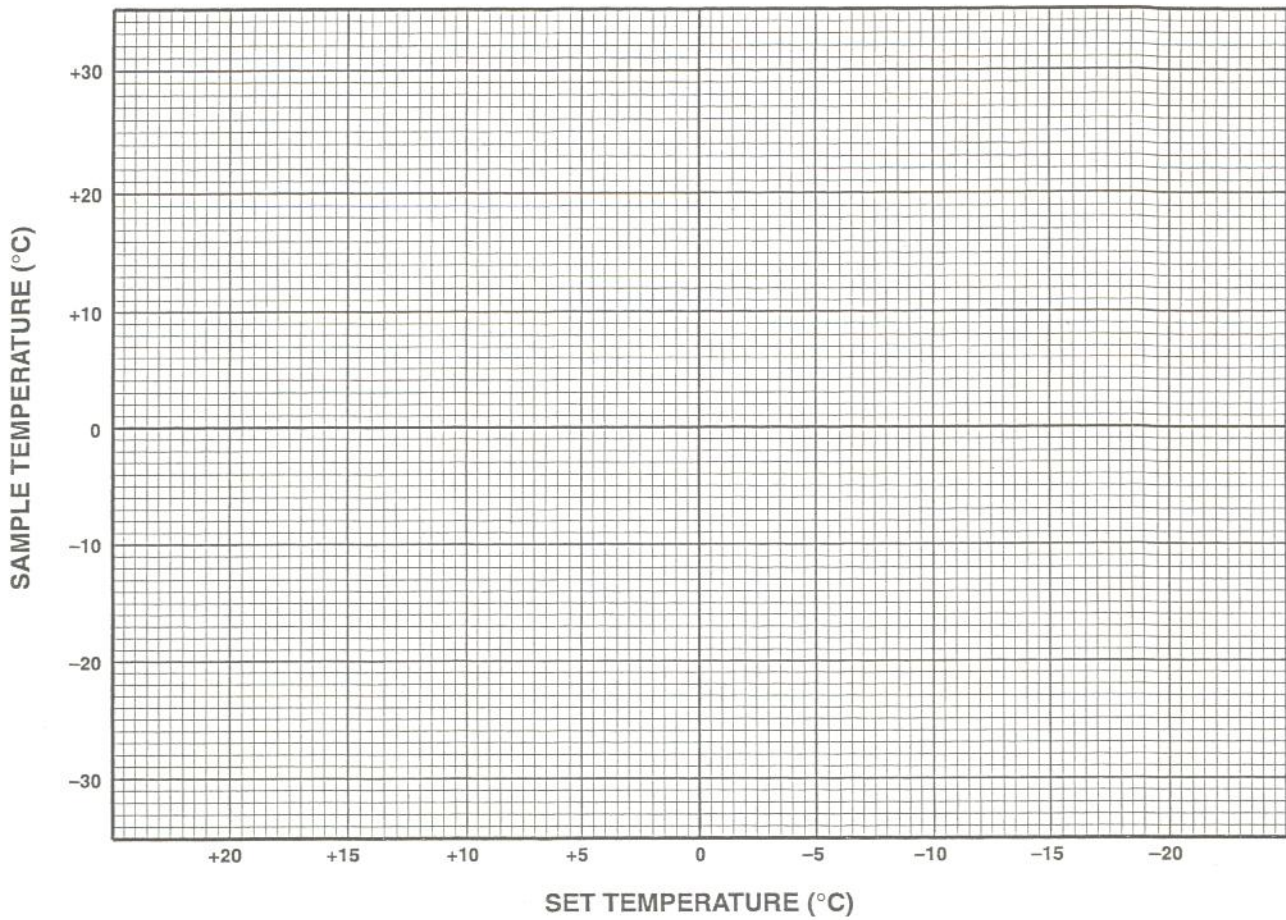

Rotor Speed/Temperature Differential Chart for

Rotor _____

Instrument _____

Ambient Temperature _____

Rotor Speed _____

Blank Rotor Speed / Temperature Differential Graph

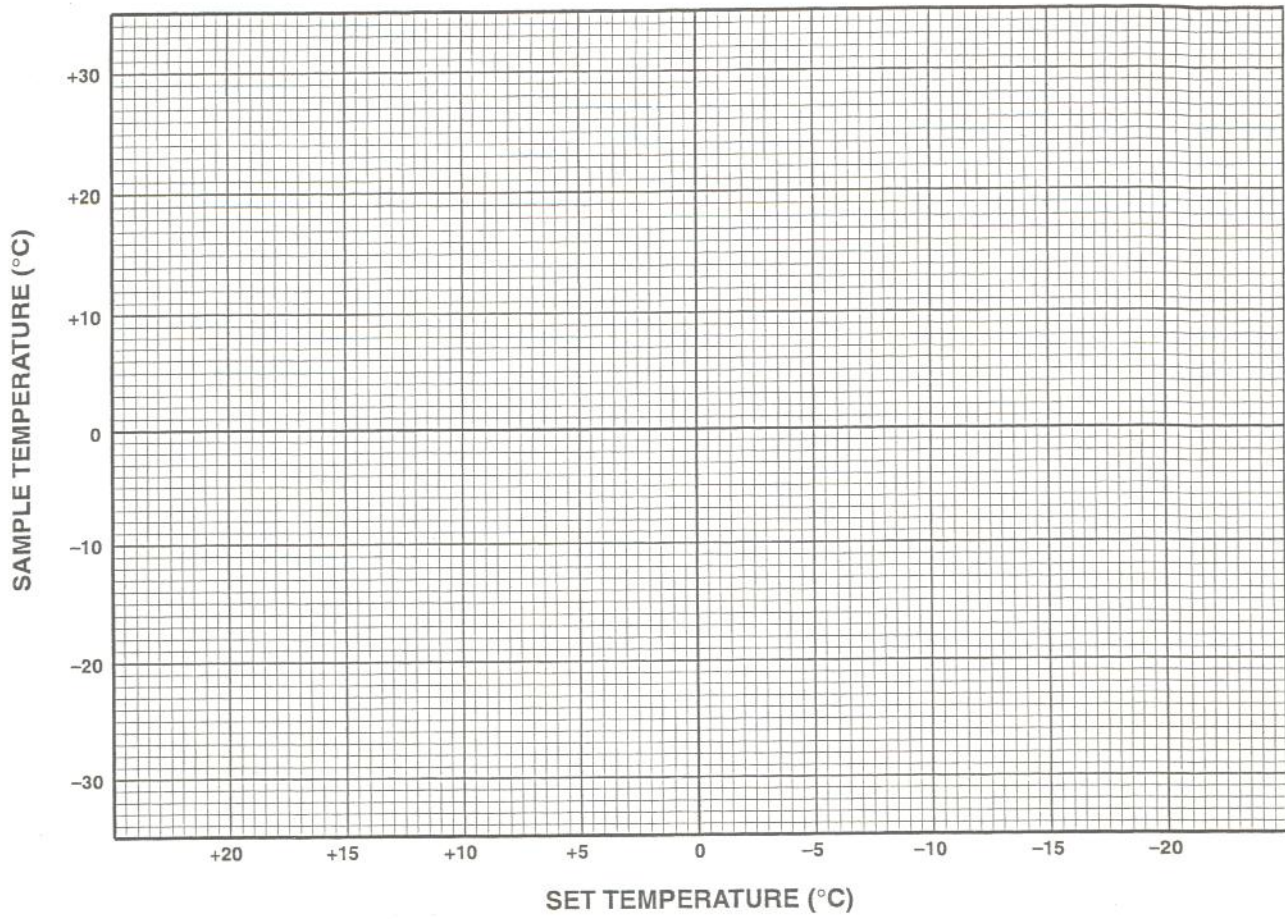

Rotor Speed/Temperature Differential Chart for

Rotor _____
Instrument _____
Ambient Temperature _____
Rotor Speed _____

Blank Rotor Speed / Temperature Differential Graph

Index

- Air Filter
 - cleaning 4-5
 - removal 4-5
- BRAKE Dial 3-2
- Brake Setting vs Deceleration Time 3-4
- Cabinet
 - cabinet 4-2
- Centrifuge Specifications
 - BRAKE Dial 1-2
 - braking time 1-2
 - circuit breakers. *See* POWER Switch
 - current. *See* Electrical Requirements
 - dimensions 1-2
 - rotor chamber diameter 1-2
 - electrical requirements. *See* Electrical Requirements
 - heat output 1-2
 - mass 1-2
 - maximum operating speed 1-2
 - Operating Temperature Range 1-2
- Circuit Breakers 4-6
- Cleaning
 - cabinet 4-2
 - door gas springs 4-2
 - drive spindle 4-1
 - refrigeration system 4-2
 - Rotor Chamber 4-1
- Cleaning the Air Filter 4-5
- Controls and Indicators 3-2
- Customer Control Inspection 4-2. *See also* Rotor Precool
 - speed control 4-2
 - timer 4-2
- Description 1-1
 - refrigeration system 1-1
- Dimensions 2-3
- Door Operation 1-5
- Electrical Requirements 2-1
- Emergency Sample Recovery 4-4. *See also* Mechanical Door Interlock Override
- IMBALANCE light 3-2
 - Inspection 2-1
 - Inspection and Cleaning 4-1
 - Installation 2-2
- Location, Centrifuge 2-2
- Lubrication 4-4
- Maintenance 4-1
- Maximum Compartment Mass 3-8. *See also* Reducing Speed for Rotor Compartment Loads in Excess of Design Mass
- Mechanical Door Interlock Override 1-5
- Mechanical Override. *See* Emergency Sample Recovery
- Normal Door Operation 1-5
- OPEN DOOR light 3-2
- Operation 3-1, 3-4
- OVERTEMP light 3-2
- Parts Ordering Information 4-6
- POWER light 3-2
- POWER Switch 3-2
- Principles of Operation 1-3
- Programmed Stop 1-4
- Reducing Speed for Rotor Compartment Loads in Excess of Design Mass 3-7
- Refrigeration System 4-2
- rev/min Indicator 3-2
- rev/min x 1000 Dial 3-2
- Rotor Installation, Loading and Balancing 3-3
- Rotor Precool 3-3
- Rotor Speed/Temperature Differential Compensation 3-5
- RUN light 3-2
- RUN Mode 1-3
- Running Hazardous Material 3-7
- Service Decontamination Policy 4-7
- STANDBY Mode 1-3
- START Switch 3-2
- STOP Switch 3-2
- TEMP °C Indicator 3-2
- TEMP SET Dial 3-2
- TIME Dial 3-2
- Unprogrammed Stop 1-4
- Warranty, *see* Appendix

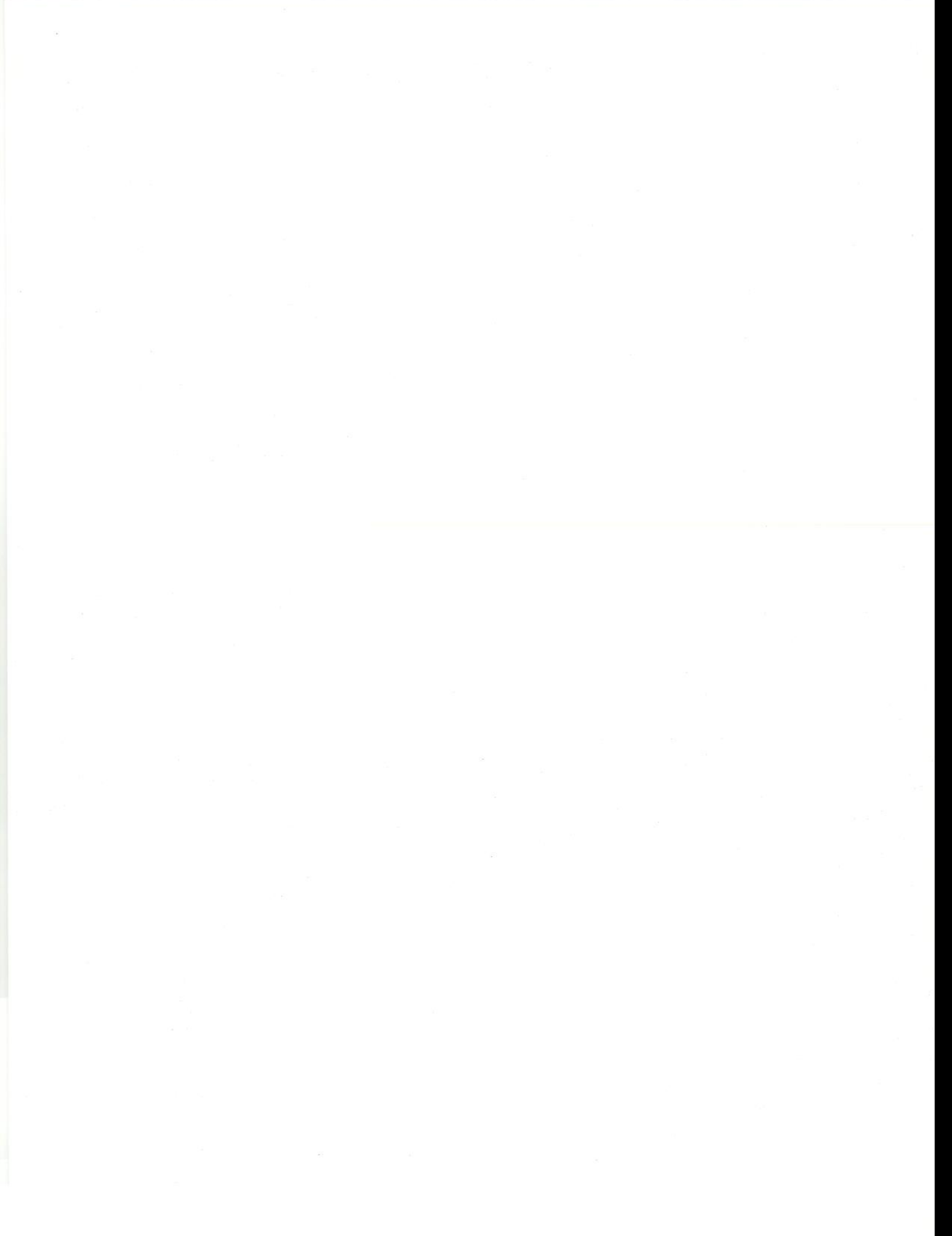

DECONTAMINATION INFORMATION CERTIFICATE

Complete and attach to equipment **BEFORE** servicing *(instructions on reverse)*

PLEASE PRINT

DECONTAMINATION CERTIFIED BY _____ TITLE/POSITION _____
PHONE _____ FAX _____ DEPARTMENT _____
INSTITUTION _____ ADDRESS _____
CITY _____ STATE _____ ZIP _____
INSTRUMENT _____ SERIAL NUMBER _____
ROTOR _____ SERIAL NUMBER _____
PART _____ PART NUMBER _____
HAZARDOUS CONTAMINANT(S) _____ DECONTAMINATION DATE _____
DECONTAMINATION METHOD(S) _____
DECONTAMINATION CERTIFIER'S SIGNATURE _____ DATE _____

DECONTAMINATION INFORMATION CERTIFICATE

Complete and attach to equipment **BEFORE** servicing *(instructions on reverse)*

PLEASE PRINT

DECONTAMINATION CERTIFIED BY _____ TITLE/POSITION _____
PHONE _____ FAX _____ DEPARTMENT _____
INSTITUTION _____ ADDRESS _____
CITY _____ STATE _____ ZIP _____
INSTRUMENT _____ SERIAL NUMBER _____
ROTOR _____ SERIAL NUMBER _____
PART _____ PART NUMBER _____
HAZARDOUS CONTAMINANT(S) _____ DECONTAMINATION DATE _____
DECONTAMINATION METHOD(S) _____
DECONTAMINATION CERTIFIER'S SIGNATURE _____ DATE _____

DECONTAMINATION INFORMATION CERTIFICATE

Complete and attach to equipment **BEFORE** servicing *(instructions on reverse)*

PLEASE PRINT

DECONTAMINATION CERTIFIED BY _____ TITLE/POSITION _____
PHONE _____ FAX _____ DEPARTMENT _____
INSTITUTION _____ ADDRESS _____
CITY _____ STATE _____ ZIP _____
INSTRUMENT _____ SERIAL NUMBER _____
ROTOR _____ SERIAL NUMBER _____
PART _____ PART NUMBER _____
HAZARDOUS CONTAMINANT(S) _____ DECONTAMINATION DATE _____
DECONTAMINATION METHOD(S) _____
DECONTAMINATION CERTIFIER'S SIGNATURE _____ DATE _____

INSTRUCTIONS

When an instrument that has been used with radioactive, pathogenic, or otherwise hazardous materials requires servicing by Kendro personnel either at the customer's laboratory or at Kendro facilities, the following procedure must be complied with to insure safety of our personnel:

1. The instrument or part to be serviced shall be cleaned of all blood and other encrusted material and decontaminated prior to servicing by our representative. No radioactivity shall be detectable by survey equipment.
2. A Decontamination Information Certificate shall be completed and attached to the instrument or part.

If an instrument or part to be serviced does not have a Decontamination Information Certificate attached to it, and, in our opinion, presents a potential radioactive or biological hazard, our representative will not service the equipment until proper decontamination

and certification has been completed. If an instrument is received at our Service facilities and, in our opinion, poses a radioactive or biological hazard, the sender will be contacted for instructions as to disposition of the equipment. Disposition costs will be borne by the sender.

Decontamination Information Certificates are included with these Operation Instructions. Additional certificates are available from your local technical or customer service representative. In the event these certificates are not available, a written statement certifying that the instrument or part has been properly decontaminated and outlining the procedures used will be acceptable.

NOTE Kendro Service representatives will indicate on a Customer Service Repair Report if decontamination was required, and if so, what the contaminate was and what procedure was used. If no decontamination was required, it should be so stated.

6/00

INSTRUCTIONS

When an instrument that has been used with radioactive, pathogenic, or otherwise hazardous materials requires servicing by Kendro personnel either at the customer's laboratory or at Kendro facilities, the following procedure must be complied with to insure safety of our personnel:

1. The instrument or part to be serviced shall be cleaned of all blood and other encrusted material and decontaminated prior to servicing by our representative. No radioactivity shall be detectable by survey equipment.
2. A Decontamination Information Certificate shall be completed and attached to the instrument or part.

If an instrument or part to be serviced does not have a Decontamination Information Certificate attached to it, and, in our opinion, presents a potential radioactive or biological hazard, our representative will not service the equipment until proper decontamination

and certification has been completed. If an instrument is received at our Service facilities and, in our opinion, poses a radioactive or biological hazard, the sender will be contacted for instructions as to disposition of the equipment. Disposition costs will be borne by the sender.

Decontamination Information Certificates are included with these Operation Instructions. Additional certificates are available from your local technical or customer service representative. In the event these certificates are not available, a written statement certifying that the instrument or part has been properly decontaminated and outlining the procedures used will be acceptable.

NOTE Kendro Service representatives will indicate on a Customer Service Repair Report if decontamination was required, and if so, what the contaminate was and what procedure was used. If no decontamination was required, it should be so stated.

6/00

INSTRUCTIONS

When an instrument that has been used with radioactive, pathogenic, or otherwise hazardous materials requires servicing by Kendro personnel either at the customer's laboratory or at Kendro facilities, the following procedure must be complied with to insure safety of our personnel:

1. The instrument or part to be serviced shall be cleaned of all blood and other encrusted material and decontaminated prior to servicing by our representative. No radioactivity shall be detectable by survey equipment.
2. A Decontamination Information Certificate shall be completed and attached to the instrument or part.

If an instrument or part to be serviced does not have a Decontamination Information Certificate attached to it, and, in our opinion, presents a potential radioactive or biological hazard, our representative will not service the equipment until proper decontamination

and certification has been completed. If an instrument is received at our Service facilities and, in our opinion, poses a radioactive or biological hazard, the sender will be contacted for instructions as to disposition of the equipment. Disposition costs will be borne by the sender.

Decontamination Information Certificates are included with these Operation Instructions. Additional certificates are available from your local technical or customer service representative. In the event these certificates are not available, a written statement certifying that the instrument or part has been properly decontaminated and outlining the procedures used will be acceptable.

NOTE Kendro Service representatives will indicate on a Customer Service Repair Report if decontamination was required, and if so, what the contaminate was and what procedure was used. If no decontamination was required, it should be so stated.

6/00

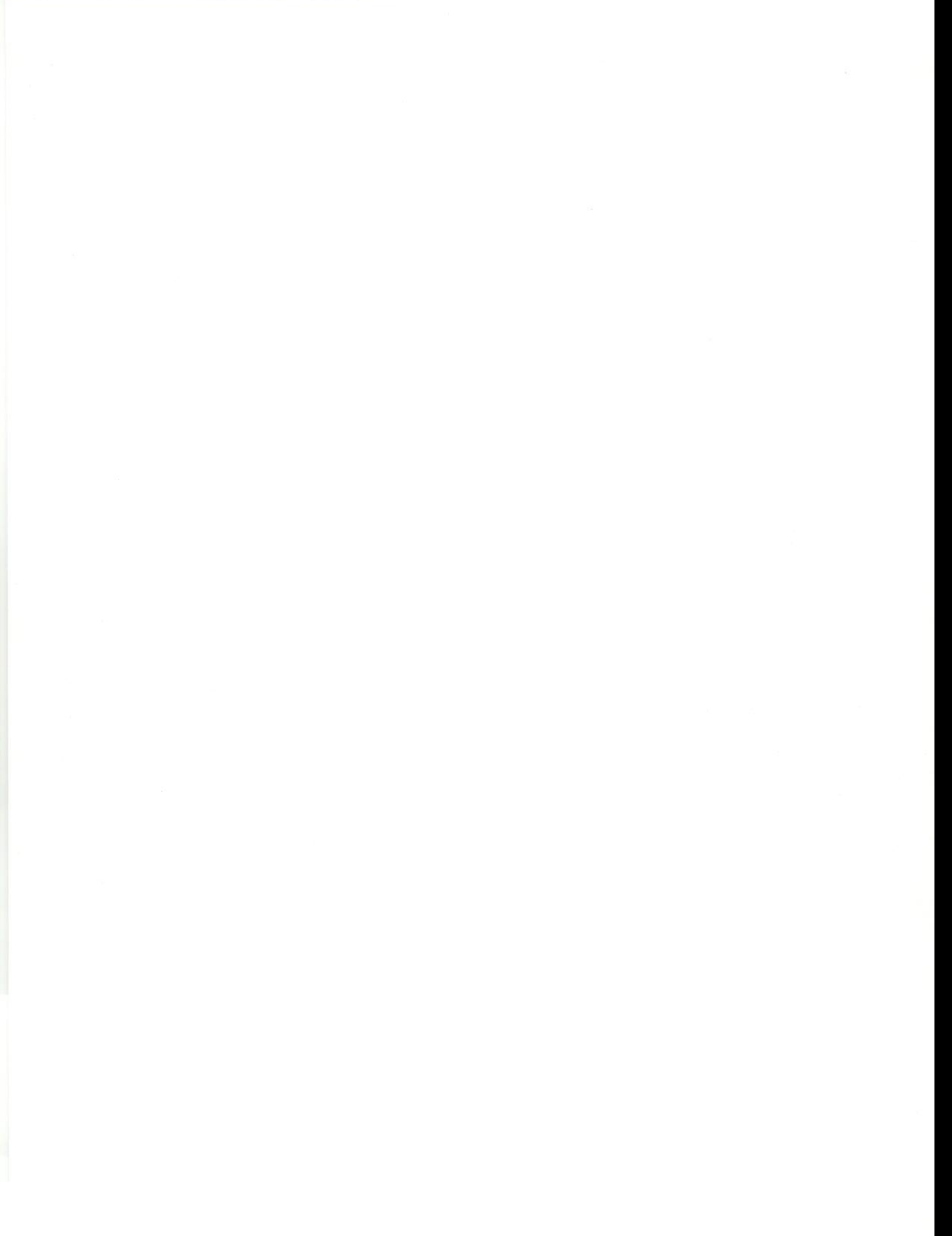

AUSTRIA

Kendro Laboratory Products GmbH
 Wiegelestraße 4
 A-1230 Vienna
 Tel.: 43 (1) 801 40-0
 Fax: 43 (1) 801 40-40
 e-mail: office@kendro.at

SWEDEN

Kendro Laboratory Products Axeb AB
 Hammarbacken 4B
 S-191 49 Sollentuna
 Tel.: 46 (8) 585 777 50
 Fax: 46 (8) 623 15 45
 e-mail: info@axeb.se

UNITED KINGDOM

Kendro Laboratory Products Limited
 Stortford Hall Park
 Bishop's Stortford
 Hertfordshire CM23 5GZ
 Tel.: 44 (1279) 827700
 Fax: 44 (1279) 827750
 e-mail: kendro@kendro.co.uk

FRANCE

Kendro Laboratory Products
 B.P. 244, Parc Hightec 6
 Batiment le Meridien
 9 Avenue du Canada
 F-91944 COURTABOEUF Cedex
 Tel.: 33 (1) 69 18 77 77
 Fax: 33 (1) 60 92 00 34
 e-mail: info@kendro.fr

SWITZERLAND

Kendro Laboratory Products AG
 Räfelstrasse 32-Postfach
 CH-8045 Zürich
 Tel.: 41 (1) 454 12 12
 Fax: 41 (1) 454 12 99
 e-mail: kendro-ag@swissonline.ch

**GERMANY or other EUROPE,
MIDDLE EAST, or AFRICA:**

Kendro Laboratory Products GmbH
 Heraeusstrasse 12-14
 D-63450 Hanau
 GERMANY
 Tel.: 49 (1805) 536 376
 Fax: 49 (1805) 112 114
 e-mail: info@kendro.de

AUSTRALIA

Kendro Laboratory Products Pty. Ltd.
 Building 4, 2-6 Orion Road
 Lane Cove, Sydney, NSW 2066
 Tel.: 61 (2) 9936 1540
 Fax: 61 (2) 9427 9765
 e-mail: info@kendro.com.au

INDIA

Kendro Laboratory Products India Pvt. Ltd.
 B-5/75 (LGF) Safdarjung Enclave
 New Delhi, 110029, India
 Tel.: 91 (11) 618 48 40
 Fax: 91 (11) 618 53 97
 e-mail: kendro.india@vsnl.com

JAPAN

Nihon Kendro Company Ltd.
 Muroichi Building, 4F
 1-13-4 Muromachi
 Nihonbashi, Chuo-ku
 Tokyo, Japan 103-0022
 Tel.: 81-3-3517-1661
 Fax: 81-3-3517-1664
 e-mail: yamakaway@kendro.co.jp

CHINA, BEIJING:

Kendro Laboratory Products
 Beijing Representative Office
 8th Floor, Office Building
 Hong Kong Macau Center
 No. 2 Chao Yang Men Bei Da Jie
 Beijing 100027, P.R. China
 Tel.: 86-(10)-6501-1573
 86-(10)-6501-3810
 Fax: 86-(10)-6501-4229
 e-mail: kendrobj@163bj.com

CHINA, SHANGHAI:

Kendro Laboratory Products
 Shanghai Representative Office
 Room 22G, Hui Jia Building
 No. 41 Cao Xi Bei Lu
 Shanghai 200030, P.R. China
 Tel.: 86-(21)-5490-0216
 86-(21)-5490-0218
 Fax: 86-(21)-5490-0230
 e-mail: kendrosh@public4.sta.net.cn

CHINA, HONG KONG**or other ASIA PACIFIC:**

Kendro Laboratory Products (H.K.) Ltd.
 Suite 1105, Chinachem Golden Plaza
 77 Mody Road, Tsimshatsui East
 Kowloon, Hong Kong
 Tel.: 852-2711-3910,
 852-2142-3910
 Fax: 852-2711-3848
 e-mail: info@kendro.com

UNITED STATES of AMERICA

Kendro Laboratory Products
 275 Aiken Road
 Asheville, NC 28804
 Tel.: 1 (800) 522-7746
 1 (828) 658-2711
 Fax: 1 (828) 665-4330
 e-mail: info@kendro.spx.com

**CANADA or other countries,
including LATIN AMERICA:**

Kendro Laboratory Products International Sales
 275 Aiken Road
 Asheville, NC 28804
 Tel.: 1 (800) 522-7746
 1 (828) 658-2711
 Fax: 1 (828) 665-4330
 e-mail: info@kendro.spx.com

Or contact a local representative for **SORVALL®** brand products. Visit our web site at <http://www.kendro.com> or <http://www.kendro.de>

SORVALL®

Kendro®